

TECHNICAL MANUAL

EF R32 3D INVERTER CONTROL



INDOOR UNIT

EF-07RD1

EF-09RD1L

EF-09RD1H

EF-12RD1M

EF-12RD1H

EF-12RD1L

EF-18RD1

EF-24RD1

OUTDOOR UNIT

MX0-07RD1

MX1-09RD1H

MX1-09RD1H

MX1-12RD1H

MX1-12RD1H

MX1-12RD1L

MX3-18RD1-EF

MX4-24RD1-EF

Table of Contents

Page

1. Specifications.....	3
1.1 Technical Specifications	3
1.2 Electrical Characteristics	11
2. Capacity Tables	12
2.1 Cooling.....	12
2.2 Heating.....	20
3. Capacity Correction Factor for Height Difference	24
4. Dimensional Drawings & Centre of gravity	27
4.1 Dimensional Drawings	27
4.2 Centre of gravity	32
5. Electrical Wiring Diagrams	34
5.1 Indoor unit.....	34
5.2 Outdoor Unit	35
6. Refrigerant Cycle Diagrams	36
7. Noise Criterion Curves	38
7.1 Indoor Unit	38
7.2 Outdoor Unit	41
8. Air Velocity and Temperature Distributions	43

1. Specifications

1.1 Technical Specifications

Model			EF-07RD1	EF-09RD1L
Power supply		V- Ph-Hz	220-240-1-50	220-240-1-50
Rated Cooling	Capacity	kW	2.10(0.88~2.46)	2.6(1.1~3.2)
Cooling Power input		kW	0.62(0.10~0.82)	0.81(0.08~1.26)
Cooling Current		A	3.00(0.40~3.70)	3.8(0.8~5.6)
Rated Heating	Capacity	kW	2.40(0.73~2.70)	2.93(0.83~3.60)
Heating Power input		kW	0.65(0.12~0.78)	0.79(0.14~1.16)
Heating Current		A	3.20(0.50~3.50)	3.7(1.2~5.2)
Seasonal Cooling	Pdesignc	kW	2.1	2.6
	SEER	W/W	7.1	7.0
	Energy Efficiency Class		A++	A++
Heating(Average)	Pdesignh	kW	1.8	2.3
	SCOP	W/W	4.1	4.1
	Energy Efficiency Class		A+	A+
	Tbiv	°C	-7	-7
Heating(Warmer)	Pdesignh	kW	2.1	2.5
	SCOP	W/W	5.2	5.1
	Energy Efficiency Class		A+++	A+++
	Tbiv	°C	2	2
Tol		°C	-20	-20
Moisture Removal		L/h	0.6	1.1
Rated Power Input		W	2,030	2200
Rated Current		A	9.0	10.0
Compressor	Model		KSK75D32UEZD31	KSN98D13UEZ32
	Type		ROTARY	ROTARY
	Brand		GMCC	GMCC
	Capacity	W	1470/2335	3050
	Input	W	235/605	800
	Rated current(RLA)	A	4.0	4.95
	Refrigerant oil/oil charge	ml	VG74 240±10	POE VG74 280±10
Indoor fan motor	Model		ZKFP-31-8-1L	ZKFP-31-8-1L
	Indoor Motor Qty		1	1
	Speed(Hi/Mi/Lo)	r/min	1050/930/870	1150/990/910
Indoor coil	a.Number of rows		1	1
	b.Tube pitch(a)x row pitch(b)	mm	18x17.3	18x17.3
	c.Fin spacing	mm	1.3	1.3
	d.Fin type (code)		Hydrophilic aluminum	Hydrophilic aluminum
	e.Tube outside dia.and type	mm	Φ5,Inner groove tube	Φ5,Inner groove tube
	f.Coil length x height x width	mm	530x72x17.3+530x108x17.3+530x108x17.3	530x72x17.3+530x108x17.3+530x108x17.3
	g.Number of circuits		2	2
Indoor air flow (Hi/Mi/Lo/Si)		m3/h	490/360/300/140	510/380/300/140
Indoor noise level (Hi/Mi/Lo/Si)		dB(A)	37.5/32/23/18	38.5/33.0/23.5/19.0
Indoor sound power level		dB(A)	56	56

Indoor unit	Dimension(W*D*H)	mm	723×199×286	723×199×286
	Packing (W*D*H)	mm	780×270×365	780×270×365
	Net/Gross weight	Kg	6.9/9.1	7.0/9.2
Outdoor fan motor	Model		ZKFN-25-10-6L	ZKFN-25-10-6L
	Speed	r/min	850/650	800/700/600
Outdoor coil	a.Number of rows		1.0	1.0
	b.Tube pitch(a)x row pitch(b)	mm	18x17.3	18x17.3
	c.Fin spacing	mm	1.3	1.3
	d.Fin type (code)		Hydrophilic aluminum	Hydrophilic aluminum
	e.Tube outside dia.and type	mm	Φ5,Inner groove tube	Φ5,Inner groove tube
	f.Coil length x height x width	mm	595x432x17.3	695x468x17.3
	g.Number of circuits		2	3
Outdoor air flow		m ³ /h	1300	1750
Outdoor sound pressure level		dB(A)	51.5	54.5
Outdoor sound power level		dB(A)	59.0	62
Outdoor unit	Dimension(W*D*H)	mm	668×252×469	720×270×495
	Packing (W*D*H)	mm	765×270×525	835×300×540
	Net/Gross weight	kg	17.8/19.5	20.4/22.3
Refrigerant	Type		R32	R32
	GWP		675	675
	Charged quantity	kg	0.4	0.46
Design pressure		MPa	4.3/1.7	4.3/1.7
Refrigerant piping	Liquid side/ Gas side	mm (inch)	Φ6.35/Φ9.52(1/4"/3/8")	Φ6.35/Φ9.52(1/4"/3/8")
	Max. refrigerant pipe length	m	25	25
	Max. difference in level	m	10	10
Connection wiring			5x1.5	5x1.5
Plug type			no-plug	no-plug
Thermostat type			Remote Control	Remote Control
Ambient temperature	Indoor(cooling/ heating)	°C	16~32/0~30	16~32/0~30
	Outdoor(cooling/heating)	°C	-15~50/-20~24	-15~50/-20~24
Application area (Cooling Standard)		m ²	10 ~14	12 ~18
Qty'per 20' /40' /40'HQ			156/327/383	140/287/320

Notes:

1) Capacities are based on the following conditions:

Cooling(T1): - Indoor Temperature 27°C(80.6°F) DB /19 °C(66.2°F) WB
 -Outdoor Temperature 35 °C(95°F) DB /24 °C(75.2°F) WB
 -Interconnecting Piping Length 5m
 - Level Difference of Zero.

Heating: - Indoor Temperature 20°C(68°F) DB / 15°C(59°F) WB
 -Outdoor Temperature 7°C(44.6°F) DB / 6°C(42.8°F) WB
 - Interconnecting Piping Length 5 m
 - Level Difference of Zero.

2) Capacities are Net Capacities.

3) Due to our policy of innovation some specifications may be changed without notification.

Model			EF-09RD1H	EF-12RD1M
Power supply		V- Ph-Hz	220-240-1-50	220-240-1-50
Rated Cooling	Capacity	kW	2.6(1.08~3.20)	3.50(1.11~3.92)
Cooling Power input		kW	0.75(0.07~1.26)	1.25(0.08~1.45)
Cooling Current		A	5.20(0.65~5.60)	5.50(0.80~6.40)
Rated Heating	Capacity	kW	2.93(0.76~3.60)	3.8(1.08~4.16)
Heating Power input		kW	0.73(0.12~1.16)	1.12(0.17~1.35)
Heating Current		A	3.30(0.95~5.20)	5.00(1.40~6.00)
Seasonal Cooling	Pdesignc	kW	2.6	3.5
	SEER	W/W	7.5	7.0
	Energy Efficiency Class		A++	A++
Heating(Average)	Pdesignh	kW	2.3	2.8
	SCOP	W/W	4.2	4.1
	Energy Efficiency Class		A+	A+
	Tbiv	°C	-7	-7
Heating(Warmer)	Pdesignh	kW	2.5	3.0
	SCOP	W/W	5.2	5.2
	Energy Efficiency Class		A+++	A+++
	Tbiv	°C	2	2
Tol		°C	-20	-20
Moisture Removal		L/h	1.1	1.2
Rated Power Input		W	2,200	2,200
Rated Current		A	10.0	10.0
Compressor	Model		KSN98D13UEZ32	KSN98D13UEZ32
	Type		ROTARY	ROTARY
	Brand		GMCC	GMCC
	Capacity	W	1915/3050±3%	1915/3050±3%
	Input	W	310/800±3%	310/800±3%
	Rated current(RLA)	A	2.35/4.95±3%	2.35/4.95±3%
	Refrigerant oil/oil charge	ml	POE VG74 280±10	POE VG74 280±10
Indoor fan motor	Model		ZKFP-30-8-357L	ZKFP-31-8-1L
	Indoor Motor Qty		1	1
	Speed(Hi/Mi/Lo)	r/min	1050/930/870	1100/940/860
Indoor coil	a.Number of rows		2	2
	b.Tube pitch(a)x row pitch(b)	mm	19.5x11.6	19.5x11.6
	c.Fin spacing	mm	1.3	1.3
	d.Fin type (code)		Hydrophilic aluminum	Hydrophilic aluminum
	e.Tube outside dia.and type	mm	Φ5,Inner groove tube	Φ5,Inner groove tube
	f.Coil length x height x width	mm	530x195x23.2+530x97.5x23.2	620x72x17.3+620x117x23.2+620x108x17.3
	g.Number of circuits		3	3
Indoor air flow (Hi/Mi/Lo/Si)		m ³ /h	510/360/285/150	600/420/340/170
Indoor noise level (Hi/Mi/Lo/Si)		dB(A)	38.5/34.5/24.5/20.5	39.5/34/24/20
Indoor sound power level		dB(A)	57	56
Indoor unit	Dimension(W*D*H)	mm	723×199×286	813×201×289
	Packing (W*D*H)	mm	780×270×365	870×270×365
	Net/Gross weight	Kg	7.5/9.6	7.575/9.975

Outdoor fan motor	Model		ZKFN-25-10-6L	ZKFN-25-10-6L
	Speed	r/min	800/700/600	800/700/600
Outdoor coil	a.Number of rows		1.0	1.0
	b.Tube pitch(a)x row pitch(b)	mm	18x17.3	21x22
	c.Fin spacing	mm	1.3	1.3
	d.Fin type (code)		Hydrophilic aluminum	Hydrophilic aluminum
	e.Tube outside dia.and type	mm	Φ5,Inner groove tube	Φ7,Inner groove tube
	f.Coil length x height x width	mm	695x468x17.3	740x462x22
	g.Number of circuits		3	2
Outdoor air flow		m ³ /h	1750	1750
Outdoor sound pressure level		dB(A)	54.5	55.0
Outdoor sound power level		dB(A)	64	65
Outdoor unit	Dimension(W*D*H)	mm	720x270x495	720x270x495
	Packing (W*D*H)	mm	828x298x540	828x298x540
	Net/Gross weight	kg	20.4/22.3	21.1/23
Refrigerant	Type		R32	R32
	GWP		675	675
	Charged quantity	kg	0.46	0.58
Design pressure		MPa	4.3/1.7	4.3/1.7
Refrigerant piping	Liquid side/ Gas side	mm (inch)	Φ6.35/Φ9.52(1/4"/3/8")	Φ6.35/Φ9.52(1/4"/3/8")
	Max. refrigerant pipe length	m	25	25
	Max. difference in level	m	10	10
Connection wiring			5x1.5	5x1.5
Plug type			no-plug	no-plug
Thermostat type			Remote Control	Remote Control
Ambient temperature	Indoor(cooling/ heating)	°C	16~32/0~30	16~32/0~30
	Outdoor(cooling/heating)	°C	-15~50/-20~24	-15~50/-20~24
Application area (Cooling Standard)		m ²	12 ~18	16 ~23
Qty'per 20' /40' /40'HQ			140/287/320	132/280/305

Notes:

1) Capacities are based on the following conditions:

Cooling(T1): - Indoor Temperature 27°C(80.6°F) DB /19 °C(66.2°F) WB
 -Outdoor Temperature 35 °C(95°F) DB /24 °C(75.2°F) WB
 -Interconnecting Piping Length 5m
 - Level Difference of Zero.

Heating: - Indoor Temperature 20°C(68°F) DB / 15°C(59°F) WB
 -Outdoor Temperature 7°C(44.6°F) DB / 6°C(42.8°F) WB
 - Interconnecting Piping Length 5 m
 - Level Difference of Zero.

2) Capacities are Net Capacities.

3) Due to our policy of innovation some specifications may be changed without notification.

Model			EF-12RD1L	EF-12RD1H
Power supply		V- Ph-Hz	220-240-1-50	220-240-1-50
Rated Cooling	Capacity	kW	3.5(1.1~3.8)	3.5(1.4~4.0)
Cooling Power input		kW	1.46(0.08~1.50)	1.2(0.12~1.35)
Cooling Current		A	6.3(0.8~6.7)	5.10(0.50~6.10)
Rated Heating	Capacity	kW	3.8(1.08~4.05)	3.8(1.07~4.30)
Heating Power input		kW	1.27(0.17~1.35)	1.04(0.11~1.25)
Heating Current		A	5.4(1.4~6.0)	4.60(0.50~5.50)
Seasonal Cooling	Pdesignc	kW	3.5	3.5
	SEER	W/W	6.5	7.5
	Energy Efficiency Class		A++	A++
Heating(Average)	Pdesignh	kW	2.8	2.8
	SCOP	W/W	4.1	4.2
	Energy Efficiency Class		A+	A+
	Tbiv	°C	-7	-7
Heating(Warmer)	Pdesignh	kW	3.0	3
	SCOP	W/W	5.2	5.3
	Energy Efficiency Class		A+++	A+++
	Tbiv	°C	2	2
Tol		°C	-20	-20
Moisture Removal		L/h	1.2	1.2
Rated Power Input		W	2200	2,200
Rated Current		A	10.0	10.0
Compressor	Model		KSN98D13UEZ32	KSN98D13UEZ32
	Type		ROTARY	ROTARY
	Brand		GMCC	GMCC
	Capacity	W	3050	3050
	Input	W	800	800
	Rated current(RLA)	A	4.95	4.95
	Refrigerant oil/oil charge	ml	POE VG74 280±10	POE VG74 280±10
Indoor fan motor	Model		ZKFP-31-8-1L	ZKFP-31-8-1L
	Indoor Motor Qty		1	1
	Speed(Hi/Mi/Lo)	r/min	1020/890/820	1000/880/820
Indoor coil	a.Number of rows		1	2
	b.Tube pitch(a)x row pitch(b)	mm	18x17.3	19.5x11.6
	c.Fin spacing	mm	1.3	1.3
	d.Fin type (code)		Hydrophilic aluminum	Hydrophilic aluminum
	e.Tube outside dia.and type	mm	Φ5,Inner groove tube	Φ5,Inner groove tube
	f.Coil length x height x width	mm	620x72x17.3+620x108x23.2+620x108x17.3	620x195x23.2+620x97.5x23.2
	g.Number of circuits		2	3
Indoor air flow (Hi/Mi/Lo/Si)		m3/h	590/420/340/190	600/450/370/220
Indoor noise level (Hi/Mi/Lo/Si)		dB(A)	39.0/32.0/24.0/20.0	38/32/25/20
Indoor sound power level		dB(A)	58	58
Indoor unit	Dimension(W*D*H)	mm	813×201×289	813×201×289
	Packing (W*D*H)	mm	870×270×365	870×270×365
	Net/Gross weight	Kg	7.4/9.7	8/10.3

Outdoor fan motor	Model		ZKFN-25-10-6L	ZKFN-25-10-6L
	Speed	r/min	810/700/600	800/700/600
Outdoor coil	a.Number of rows		1.0	1.0
	b.Tube pitch(a)x row pitch(b)	mm	18x17.3	21x22
	c.Fin spacing	mm	1.3	1.3
	d.Fin type (code)		Hydrophilic aluminum	Inner groove tube
	e.Tube outside dia.and type	mm	Φ5,Inner groove tube	Φ7,Inner groove tube
	f.Coil length x height x width	mm	695x468x17.3	740x462x22
	g.Number of circuits		3	2
Outdoor air flow		m ³ /h	1750	1750
Outdoor sound pressure level		dB(A)	56.0	56.0
Outdoor sound power level		dB(A)	65	65
Outdoor unit	Dimension(W*D*H)	mm	720x270x495	720x270x495
	Packing (W*D*H)	mm	828x298x540	828x298x540
	Net/Gross weight	kg	20.4/22.3	21.1/23
Refrigerant	Type		R32	R32
	GWP		675	675
	Charged quantity	kg	0.49	0.58
Design pressure		MPa	4.3/1.7	4.3/1.7
Refrigerant piping	Liquid side/ Gas side	mm (inch)	Φ6.35/Φ9.52(1/4"/3/8")	Φ6.35/Φ9.52(1/4"/3/8")
	Max. refrigerant pipe length	m	25	25
	Max. difference in level	m	10	10
Connection wiring			5x1.5	5x1.5
Plug type			no-plug	no-plug
Thermostat type			Remote Control	Remote Control
Ambient temperature	Indoor(cooling/ heating)	°C	16~32/0~30	16~32/0~30
	Outdoor(cooling/heating)	°C	-15~50/-20~24	-15~50/-20~24
Application area (Cooling Standard)		m ²	16 ~23	16 ~23
Qty'per 20' /40' /40'HQ			132/280/305	132/280/305

Notes:

1) Capacities are based on the following conditions:

Cooling(T1): - Indoor Temperature 27°C(80.6°F) DB /19 °C(66.2°F) WB
 -Outdoor Temperature 35 °C(95°F) DB /24 °C(75.2°F) WB
 -Interconnecting Piping Length 5m
 - Level Difference of Zero.

Heating: - Indoor Temperature 20°C(68°F) DB / 15°C(59°F) WB
 -Outdoor Temperature 7°C(44.6°F) DB / 6°C(42.8°F) WB
 - Interconnecting Piping Length 5 m
 - Level Difference of Zero.

2) Capacities are Net Capacities.

3) Due to our policy of innovation some specifications may be changed without notification.

Model			EF-18RD1	EF-24RD1
Power supply		V- Ph-Hz	220-240-1-50	220-240-1-50
Rated Cooling	Capacity	kW	5.2(1.8~5.9)	7.0(2.0~7.8)
Cooling Power input		kW	1.68(0.14~2.10)	2.60(0.42~3.90)
Cooling Current		A	7.1(0.6~9.3)	11.5(1.8~19.0)
Rated Heating	Capacity	kW	5.40(1.30~6.10)	7.33(1.60~7.80)
Heating Power input		kW	1.38(0.22~1.70)	2.15(0.30~2.50)
Heating Current		A	6.1(0.9~7.6)	11.0(1.3~11.1)
Seasonal Cooling	Pdesignc	kW	5.2	7.0
	SEER	W/W	7.4	6.5
	Energy Efficiency Class		A++	A++
Heating(Average)	Pdesignh	kW	4.1	4.8
	SCOP	W/W	4.1	4.1
	Energy Efficiency Class		A+	A+
	Tbiv	°C	-7	-7
Heating(Warmer)	Pdesignh	kW	4.6	5.6
	SCOP	W/W	5.1	5.1
	Energy Efficiency Class		A+++	A+++
	Tbiv	°C	2	2
Tol		°C	-20	-20
Moisture Removal		L/h	2.0	2.9
Rated Power Input		W	2800	3900
Rated Current		A	13	19
Compressor	Model		KSN140D33UFZB3	KTM29000D27UKT3
	Type		ROTARY	ROTARY
	Brand		GMCC	GMCC
	Capacity	W	4350	7270
	Input	W	1127	1980
	Rated current(RLA)	A	6.9	9.15
	Refrigerant oil/oil charge	ml	ESTER OIL VG74 420±10	POE VG74 500±15
Indoor fan motor	Model		ZKFP-35-10-188L	ZKFP-58-8-26L
	Indoor Motor Qty		1	1
	Speed(Hi/Mi/Lo)	r/min	1000/868/802	1050/910/840
Indoor coil	a.Number of rows		2	2
	b.Tube pitch(a)x row pitch(b)	mm	19.5x11.6	19.5x11.6
	c.Fin spacing	mm	1.3	1.3
	d.Fin type (code)		Hydrophilic aluminum	Hydrophilic aluminum
	e.Tube outside dia.and type	mm	Φ5,Inner groove tube	Φ5,Inner groove tube
	f.Coil length x height x width	mm	770x195x23.2+770x117x23.2	820x214.5x23.2+820x117x23.2
	g.Number of circuits		4	6
Indoor air flow (Hi/Mi/Lo/Si)		m3/h	800/600/470/340	1050/750/600/400
Indoor noise level (Hi/Mi/Lo/Si)		dB(A)	43.0/35.5/33.5/20.0	45.0/39.5/36.0/20.0
Indoor sound power level		dB(A)	58	59
Indoor unit	Dimension(W*D*H)	mm	975x218x308	1055x231x330
	Packing (W*D*H)	mm	1035x295x385	1130x405x310
	Net/Gross weight	Kg	10.3/13.3	12.4/15.9

Outdoor fan motor	Model		ZKFN-34-10-1L-1	ZKFN-80-10-1L-1
	Speed	r/min	830/700/650	900/550
Outdoor coil	a.Number of rows		2.0	1.6
	b.Tube pitch(a)x row pitch(b)	mm	18x17.3	18x17.3
	c.Fin spacing	mm	1.3	1.3
	d.Fin type (code)		Hydrophilic aluminum	Hydrophilic aluminum
	e.Tube outside dia.and type	mm	Φ5,Inner groove tube	Φ5,Inner groove tube
	f.Coil length x height x width	mm	870x504x34.6	900*612*17.3+540*612*17.3
	g.Number of circuits		8	8
Outdoor air flow		m ³ /h	2100	3500
Outdoor sound pressure level		dB(A)	57.5	60.0
Outdoor sound power level		dB(A)	65	68
Outdoor unit	Dimension(W*D*H)	mm	805x330x554	890x342x673
	Packing (W*D*H)	mm	915x370x615	995x398x740
	Net/Gross weight	kg	29.8/32.3	38.3/41.5
Refrigerant	Type		R32	R32
	GWP		675	675
	Charged quantity	kg	0.80	0.95
Design pressure		MPa	4.3/1.7	4.3/1.7
Refrigerant piping	Liquid side/ Gas side	mm (inch)	Φ6.35/Φ12.7(1/4"/1/2")	Φ6.35/Φ12.7(1/4"/1/2")
	Max. refrigerant pipe length	m	30	50
	Max. difference in level	m	20	25
Connection wiring			5x1.5	5x1.5
Plug type			no-plug	no-plug
Thermostat type			Remote Control	Remote Control
Ambient temperature	Indoor(cooling/ heating)	°C	16~32/0~30	16~32/0~30
	Outdoor(cooling/heating)	°C	-15~50/-20~24	-15~50/-20~24
Application area (Cooling Standard)		m ²	24~35	32~47
Qty'per 20' /40' /40'HQ			86/182/208	65/135/156

Notes:

1) Capacities are based on the following conditions:

Cooling(T1): - Indoor Temperature 27°C(80.6°F) DB /19 °C(66.2°F) WB
 -Outdoor Temperature 35 °C(95°F) DB /24 °C(75.2°F) WB
 -Interconnecting Piping Length 5m
 - Level Difference of Zero.

Heating: - Indoor Temperature 20°C(68°F) DB / 15°C(59°F) WB
 -Outdoor Temperature 7°C(44.6°F) DB / 6°C(42.8°F) WB
 - Interconnecting Piping Length 5 m
 - Level Difference of Zero.

2) Capacities are Net Capacities.

3) Due to our policy of innovation some specifications may be changed without notification.

1.2 Electrical Characteristics

Model	Outdoor Unit			Power Supply			IFM		Compressor		OFM		
	Phase	Hz	Voltage	MCA	MOP	MFA	W	FLA	MSC	RLA	Qty	W	FLA
EF-07RD1	1	50	220-240 Min:198 Max:264	5.83	9.78	15	31	0.218	/	3.95	1	25	0.674
EF-09RD1L				7.08	12.03	15	31	0.218	/	4.95	1	25	0.674
EF-09RD1H				7.15	12.10	15	35	0.29	/	4.95	1	25	0.674
EF-12RD1H EF-12RD1L EF-12RD1M				7.08	12.03	15	31	0.218	/	4.95	1	25	0.674
EF-18RD1				9.67	16.57	20	35	0.31	/	6.9	1	34	0.73
EF-24RD1				12.73	21.88	25	58	0.52	/	9.15	1	80	0.852

Notes:

MCA: Minimum Circuit Amperes (A)

MOP: Maximum rating over current protective device

MFA: Maximum Fuse Amperes (A)

MSC: Maximum Starting Current

RLA: Rated Load Amperes (A)

IFM: Indoor Fan Motor

OFM: Outdoor Fan Motor

FLA: Full Load Amperes (A)

2. Capacity Tables

2.1 Cooling

EF-07RD1+MX0-07RD1																		
INDOOR AIRFLOW (CMH)	OUTDOOR DB(°C)	ID WB (°C)	16.0				18.0				19.0				22.0			
			ID DB (°C)				ID DB (°C)				ID DB (°C)				ID DB (°C)			
			23.0	25.0	27.0	29.0	23.0	25.0	27.0	29.0	23.0	25.0	27.0	29.0	23.0	25.0	27.0	29.0
490	-15	TC	2.31	2.31	2.31	2.32	2.45	2.45	2.45	2.46	2.59	2.60	2.60	2.60	2.75	2.75	2.76	2.76
		S/T	0.63	0.74	0.84	0.96	0.60	0.70	0.80	0.91	0.56	0.66	0.75	0.86	0.53	0.62	0.71	0.81
		PI	0.33	0.33	0.33	0.33	0.35	0.35	0.35	0.35	0.37	0.37	0.37	0.37	0.39	0.39	0.39	0.40
	-10	TC	2.18	2.18	2.18	2.19	2.31	2.31	2.32	2.32	2.45	2.45	2.45	2.46	2.60	2.60	2.60	2.61
		S/T	0.62	0.73	0.83	0.94	0.59	0.69	0.78	0.89	0.55	0.65	0.74	0.84	0.52	0.61	0.69	0.79
		PI	0.32	0.32	0.32	0.32	0.34	0.34	0.34	0.34	0.36	0.36	0.36	0.36	0.38	0.38	0.38	0.38
	-5	TC	2.13	2.13	2.13	2.14	2.26	2.26	2.26	2.27	2.39	2.40	2.40	2.40	2.54	2.54	2.54	2.55
		S/T	0.61	0.72	0.81	0.93	0.58	0.68	0.77	0.88	0.54	0.64	0.72	0.83	0.51	0.60	0.68	0.78
		PI	0.30	0.30	0.31	0.31	0.32	0.32	0.32	0.32	0.34	0.34	0.34	0.34	0.36	0.36	0.36	0.36
	0	TC	2.12	2.12	2.12	2.13	2.25	2.25	2.25	2.25	2.38	2.38	2.39	2.39	2.52	2.53	2.53	2.53
		S/T	0.60	0.71	0.80	0.91	0.57	0.67	0.76	0.86	0.54	0.63	0.71	0.81	0.50	0.59	0.67	0.77
		PI	0.29	0.29	0.29	0.29	0.31	0.31	0.31	0.31	0.32	0.32	0.33	0.33	0.34	0.34	0.34	0.35
	5	TC	2.00	2.00	2.00	2.00	2.12	2.12	2.12	2.12	2.24	2.25	2.25	2.25	2.38	2.38	2.38	2.39
		S/T	0.61	0.72	0.82	0.93	0.58	0.68	0.77	0.88	0.54	0.64	0.73	0.83	0.51	0.60	0.69	0.78
		PI	0.26	0.26	0.26	0.27	0.28	0.28	0.28	0.28	0.30	0.30	0.30	0.30	0.31	0.31	0.32	0.32
	10	TC	1.87	1.87	1.88	1.88	1.98	1.99	1.99	1.99	2.10	2.11	2.11	2.11	2.23	2.23	2.23	2.24
		S/T	0.62	0.73	0.82	0.94	0.58	0.68	0.78	0.89	0.55	0.65	0.73	0.84	0.52	0.61	0.69	0.79
		PI	0.25	0.25	0.25	0.25	0.27	0.27	0.27	0.27	0.28	0.28	0.29	0.29	0.30	0.30	0.30	0.30
	15	TC	1.85	1.85	1.85	1.86	1.96	1.96	1.97	1.97	2.08	2.08	2.08	2.09	2.20	2.21	2.21	2.21
		S/T	0.60	0.70	0.80	0.91	0.56	0.66	0.75	0.86	0.53	0.62	0.71	0.81	0.50	0.59	0.67	0.76
		PI	0.28	0.28	0.28	0.28	0.30	0.30	0.30	0.30	0.31	0.31	0.31	0.31	0.33	0.33	0.33	0.33
	20	TC	1.83	1.83	1.83	1.83	1.94	1.94	1.94	1.94	2.05	2.06	2.06	2.06	2.18	2.18	2.18	2.18
		S/T	0.58	0.68	0.77	0.88	0.54	0.64	0.72	0.83	0.51	0.60	0.68	0.78	0.48	0.57	0.65	0.74
		PI	0.30	0.30	0.30	0.31	0.32	0.32	0.32	0.32	0.34	0.34	0.34	0.34	0.36	0.36	0.36	0.36
	25	TC	1.81	1.81	1.81	1.81	1.91	1.92	1.92	1.92	2.03	2.03	2.03	2.04	2.15	2.15	2.16	2.16
		S/T	0.55	0.65	0.74	0.84	0.52	0.61	0.70	0.80	0.49	0.58	0.66	0.75	0.47	0.55	0.62	0.71
		PI	0.33	0.33	0.33	0.33	0.35	0.35	0.35	0.35	0.37	0.37	0.37	0.37	0.39	0.39	0.39	0.39
	30	TC	1.82	1.83	1.83	1.83	1.93	1.94	1.94	1.94	2.05	2.05	2.05	2.06	2.17	2.18	2.18	2.18
		S/T	0.58	0.69	0.78	0.89	0.55	0.65	0.74	0.84	0.52	0.61	0.69	0.79	0.49	0.58	0.65	0.75
		PI	0.42	0.42	0.42	0.42	0.45	0.45	0.45	0.45	0.47	0.48	0.48	0.48	0.50	0.50	0.50	0.50
	35	TC	1.86	1.87	1.87	1.87	1.98	1.98	1.98	1.98	2.09	2.10	2.10	2.10	2.22	2.22	2.23	2.23
		S/T	0.64	0.75	0.85	0.97	0.60	0.71	0.81	0.92	0.57	0.67	0.76	0.87	0.54	0.63	0.72	0.82
		PI	0.55	0.55	0.55	0.55	0.58	0.58	0.58	0.59	0.62	0.62	0.62	0.62	0.66	0.66	0.66	0.66
	40	TC	1.62	1.62	1.62	1.62	1.71	1.72	1.72	1.72	1.82	1.82	1.82	1.82	1.93	1.93	1.93	1.93
		S/T	0.69	0.81	0.92	1.00	0.65	0.76	0.87	0.99	0.61	0.72	0.82	0.93	0.58	0.68	0.77	0.88
		PI	0.49	0.49	0.49	0.49	0.52	0.52	0.52	0.52	0.55	0.55	0.55	0.55	0.58	0.58	0.58	0.58
	45	TC	1.25	1.25	1.25	1.26	1.33	1.33	1.33	1.33	1.40	1.41	1.41	1.41	1.49	1.49	1.49	1.49
		S/T	0.73	0.86	0.98	1.00	0.69	0.81	0.92	1.00	0.65	0.77	0.87	0.99	0.62	0.72	0.82	0.94
		PI	0.40	0.40	0.40	0.40	0.43	0.43	0.43	0.43	0.45	0.45	0.45	0.45	0.48	0.48	0.48	0.48
	50	TC	0.71	0.71	0.71	0.71	0.75	0.75	0.75	0.75	0.79	0.80	0.80	0.80	0.84	0.84	0.84	0.85
		S/T	0.75	0.88	1.00	1.00	0.73	0.86	0.98	1.00	0.69	0.81	0.92	1.00	0.65	0.76	0.87	0.99
		PI	0.28	0.28	0.28	0.28	0.29	0.29	0.29	0.29	0.31	0.31	0.31	0.31	0.33	0.33	0.33	0.33

TC:Total Cooling Capacity (kW)

S/T:Sensible Cooling Capacity Ratio

PI:Power Input(kW)

Note: The table shows the case where the operation frequency of a compressor is fixed.

EF-09RD1L+MX1-09RD1H																		
INDOOR AIRFLOW (CMH)	OUTDOOR DB(°C)	ID WB (°C)	16.0				18.0				19.0				22.0			
		ID DB (°C)	23.0	25.0	27.0	29.0	23.0	25.0	27.0	29.0	23.0	25.0	27.0	29.0	23.0	25.0	27.0	29.0
510	-15	TC	2.86	2.86	2.86	2.87	3.03	3.03	3.04	3.04	3.21	3.22	3.22	3.22	3.40	3.41	3.41	3.42
		S/T	0.63	0.74	0.84	0.96	0.60	0.70	0.80	0.91	0.56	0.66	0.75	0.86	0.53	0.62	0.71	0.81
		PI	0.44	0.44	0.44	0.44	0.46	0.46	0.46	0.47	0.49	0.49	0.49	0.49	0.52	0.52	0.52	0.52
	-10	TC	2.70	2.70	2.70	2.71	2.86	2.86	2.87	2.87	3.03	3.04	3.04	3.04	3.21	3.22	3.22	3.23
		S/T	0.62	0.73	0.83	0.94	0.59	0.69	0.78	0.89	0.55	0.65	0.74	0.84	0.52	0.61	0.69	0.79
		PI	0.42	0.42	0.42	0.42	0.45	0.45	0.45	0.45	0.47	0.47	0.48	0.48	0.50	0.50	0.50	0.50
	-5	TC	2.64	2.64	2.64	2.65	2.79	2.80	2.80	2.80	2.96	2.97	2.97	2.97	3.14	3.14	3.15	3.15
		S/T	0.61	0.72	0.81	0.93	0.58	0.68	0.77	0.88	0.54	0.64	0.72	0.83	0.51	0.60	0.68	0.78
		PI	0.40	0.40	0.40	0.40	0.43	0.43	0.43	0.43	0.45	0.45	0.45	0.45	0.48	0.48	0.48	0.48
	0	TC	2.62	2.63	2.63	2.63	2.78	2.78	2.79	2.79	2.95	2.95	2.95	2.96	3.12	3.13	3.13	3.14
		S/T	0.60	0.71	0.80	0.91	0.57	0.67	0.76	0.86	0.54	0.63	0.71	0.81	0.50	0.59	0.67	0.77
		PI	0.38	0.38	0.38	0.38	0.40	0.41	0.41	0.41	0.43	0.43	0.43	0.43	0.45	0.46	0.46	0.46
	5	TC	2.47	2.48	2.48	2.48	2.62	2.62	2.63	2.63	2.78	2.78	2.78	2.79	2.95	2.95	2.95	2.96
		S/T	0.61	0.72	0.82	0.93	0.58	0.68	0.77	0.88	0.54	0.64	0.73	0.83	0.51	0.60	0.69	0.78
		PI	0.35	0.35	0.35	0.35	0.37	0.37	0.37	0.37	0.39	0.39	0.39	0.39	0.42	0.42	0.42	0.42
	10	TC	2.32	2.32	2.32	2.33	2.46	2.46	2.46	2.47	2.60	2.61	2.61	2.61	2.76	2.76	2.77	2.77
		S/T	0.62	0.73	0.82	0.94	0.58	0.68	0.78	0.89	0.55	0.65	0.73	0.84	0.52	0.61	0.69	0.79
		PI	0.34	0.34	0.34	0.34	0.36	0.36	0.36	0.36	0.38	0.38	0.38	0.38	0.40	0.40	0.40	0.40
	15	TC	2.29	2.29	2.30	2.30	2.43	2.43	2.43	2.44	2.57	2.58	2.58	2.58	2.73	2.73	2.73	2.74
		S/T	0.60	0.70	0.80	0.91	0.56	0.66	0.75	0.86	0.53	0.62	0.71	0.81	0.50	0.59	0.67	0.76
		PI	0.37	0.37	0.37	0.37	0.39	0.39	0.39	0.39	0.41	0.41	0.41	0.42	0.44	0.44	0.44	0.44
	20	TC	2.26	2.27	2.27	2.27	2.40	2.40	2.40	2.41	2.54	2.55	2.55	2.55	2.70	2.70	2.70	2.71
		S/T	0.58	0.68	0.77	0.88	0.54	0.64	0.72	0.83	0.51	0.60	0.68	0.78	0.48	0.57	0.65	0.74
		PI	0.40	0.40	0.40	0.40	0.43	0.43	0.43	0.43	0.45	0.45	0.45	0.45	0.48	0.48	0.48	0.48
	25	TC	2.24	2.24	2.24	2.24	2.37	2.37	2.38	2.38	2.51	2.51	2.52	2.52	2.66	2.67	2.67	2.67
		S/T	0.55	0.65	0.74	0.84	0.52	0.61	0.70	0.80	0.49	0.58	0.66	0.75	0.47	0.55	0.62	0.71
		PI	0.44	0.44	0.44	0.44	0.46	0.46	0.46	0.46	0.49	0.49	0.49	0.49	0.52	0.52	0.52	0.52
	30	TC	2.26	2.26	2.26	2.27	2.39	2.40	2.40	2.40	2.54	2.54	2.54	2.55	2.69	2.69	2.70	2.70
		S/T	0.58	0.69	0.78	0.89	0.55	0.65	0.74	0.84	0.52	0.61	0.69	0.79	0.49	0.58	0.65	0.75
		PI	0.56	0.56	0.56	0.56	0.59	0.59	0.59	0.59	0.63	0.63	0.63	0.63	0.67	0.67	0.67	0.67
	35	TC	2.31	2.31	2.31	2.32	2.45	2.45	2.45	2.46	2.59	2.60	2.60	2.60	2.75	2.75	2.76	2.76
		S/T	0.64	0.75	0.85	0.97	0.60	0.71	0.81	0.92	0.57	0.67	0.76	0.87	0.54	0.63	0.72	0.82
		PI	0.73	0.73	0.73	0.73	0.77	0.77	0.77	0.77	0.82	0.82	0.82	0.82	0.87	0.87	0.87	0.87
	40	TC	2.00	2.00	2.01	2.01	2.12	2.12	2.13	2.13	2.25	2.25	2.25	2.26	2.38	2.39	2.39	2.39
		S/T	0.69	0.81	0.92	1.00	0.65	0.76	0.87	0.99	0.61	0.72	0.82	0.93	0.58	0.68	0.77	0.88
		PI	0.65	0.65	0.65	0.65	0.69	0.69	0.69	0.69	0.73	0.73	0.73	0.73	0.77	0.77	0.77	0.77
	45	TC	1.55	1.55	1.55	1.55	1.64	1.64	1.64	1.65	1.74	1.74	1.74	1.75	1.84	1.85	1.85	1.85
		S/T	0.73	0.86	0.98	1.00	0.69	0.81	0.92	1.00	0.65	0.77	0.87	0.99	0.62	0.72	0.82	0.94
		PI	0.53	0.53	0.53	0.53	0.56	0.56	0.56	0.57	0.60	0.60	0.60	0.60	0.63	0.63	0.63	0.64
	50	TC	0.88	0.88	0.88	0.88	0.93	0.93	0.93	0.93	0.98	0.98	0.99	0.99	1.04	1.04	1.04	1.05
		S/T	0.75	0.88	1.00	1.00	0.73	0.86	0.98	1.00	0.69	0.81	0.92	1.00	0.65	0.76	0.87	0.99
		PI	0.37	0.37	0.37	0.37	0.39	0.39	0.39	0.39	0.41	0.41	0.41	0.41	0.43	0.44	0.44	0.44

TC:Total Cooling Capacity (kW)

S/T:Sensible Cooling Capacity Ratio

PI:Power Input(kW)

Note: The table shows the case where the operation frequency of a compressor is fixed.

EF-09RD1H+MX1-09RD1H																		
INDOOR AIRFLOW (CMH)	OUTDOOR DB(°C)	ID WB (°C)	16.0				18.0				19.0				22.0			
		ID DB (°C)	23.0	25.0	27.0	29.0	23.0	25.0	27.0	29.0	23.0	25.0	27.0	29.0	23.0	25.0	27.0	29.0
510	-15	TC	2.90	2.91	2.91	2.91	3.08	3.08	3.08	3.09	3.26	3.26	3.27	3.27	3.46	3.46	3.46	3.47
		S/T	0.63	0.74	0.84	0.96	0.60	0.70	0.80	0.91	0.56	0.66	0.75	0.86	0.53	0.62	0.71	0.81
		PI	0.41	0.41	0.41	0.41	0.43	0.43	0.43	0.43	0.46	0.46	0.46	0.46	0.46	0.48	0.48	0.48
	-10	TC	2.74	2.74	2.75	2.75	2.90	2.91	2.91	2.91	3.08	3.08	3.09	3.09	3.26	3.27	3.27	3.28
		S/T	0.62	0.73	0.83	0.94	0.59	0.69	0.78	0.89	0.55	0.65	0.74	0.84	0.52	0.61	0.69	0.79
		PI	0.39	0.39	0.39	0.39	0.41	0.42	0.42	0.42	0.44	0.44	0.44	0.44	0.47	0.47	0.47	0.47
	-5	TC	2.68	2.68	2.68	2.69	2.84	2.84	2.84	2.85	3.01	3.01	3.01	3.02	3.19	3.19	3.20	3.20
		S/T	0.61	0.72	0.81	0.93	0.58	0.68	0.77	0.88	0.54	0.64	0.72	0.83	0.51	0.60	0.68	0.78
		PI	0.37	0.37	0.37	0.37	0.40	0.40	0.40	0.40	0.42	0.42	0.42	0.42	0.44	0.45	0.45	0.45
	0	TC	2.66	2.67	2.67	2.67	2.82	2.83	2.83	2.83	2.99	3.00	3.00	3.00	3.17	3.18	3.18	3.18
		S/T	0.60	0.71	0.80	0.91	0.57	0.67	0.76	0.86	0.54	0.63	0.71	0.81	0.50	0.59	0.67	0.77
		PI	0.35	0.35	0.35	0.36	0.38	0.38	0.38	0.38	0.40	0.40	0.40	0.40	0.42	0.42	0.42	0.42
	5	TC	2.51	2.51	2.52	2.52	2.66	2.67	2.67	2.67	2.82	2.82	2.83	2.83	2.99	2.99	3.00	3.00
		S/T	0.61	0.72	0.82	0.93	0.58	0.68	0.77	0.88	0.54	0.64	0.73	0.83	0.51	0.60	0.69	0.78
		PI	0.32	0.32	0.32	0.32	0.34	0.34	0.34	0.34	0.36	0.36	0.36	0.37	0.39	0.39	0.39	0.39
	10	TC	2.35	2.36	2.36	2.36	2.49	2.50	2.50	2.50	2.64	2.65	2.65	2.65	2.80	2.81	2.81	2.81
		S/T	0.62	0.73	0.82	0.94	0.58	0.68	0.78	0.89	0.55	0.65	0.73	0.84	0.52	0.61	0.69	0.79
		PI	0.31	0.31	0.31	0.31	0.33	0.33	0.33	0.33	0.35	0.35	0.35	0.35	0.37	0.37	0.37	0.37
	15	TC	2.33	2.33	2.33	2.33	2.47	2.47	2.47	2.47	2.61	2.62	2.62	2.62	2.77	2.77	2.78	2.78
		S/T	0.60	0.70	0.80	0.91	0.56	0.66	0.75	0.86	0.53	0.62	0.71	0.81	0.50	0.59	0.67	0.76
		PI	0.34	0.34	0.34	0.34	0.36	0.36	0.36	0.36	0.38	0.38	0.38	0.39	0.41	0.41	0.41	0.41
	20	TC	2.30	2.30	2.30	2.31	2.44	2.44	2.44	2.44	2.58	2.58	2.59	2.59	2.74	2.74	2.74	2.75
		S/T	0.58	0.68	0.77	0.88	0.54	0.64	0.72	0.83	0.51	0.60	0.68	0.78	0.48	0.57	0.65	0.74
		PI	0.37	0.37	0.37	0.37	0.39	0.40	0.40	0.40	0.42	0.42	0.42	0.42	0.44	0.44	0.44	0.45
	25	TC	2.27	2.27	2.28	2.28	2.41	2.41	2.41	2.42	2.55	2.55	2.56	2.56	2.70	2.71	2.71	2.71
		S/T	0.55	0.65	0.74	0.84	0.52	0.61	0.70	0.80	0.49	0.58	0.66	0.75	0.47	0.55	0.62	0.71
		PI	0.40	0.40	0.40	0.41	0.43	0.43	0.43	0.43	0.45	0.45	0.45	0.46	0.48	0.48	0.48	0.48
	30	TC	2.29	2.30	2.30	2.30	2.43	2.43	2.44	2.44	2.58	2.58	2.58	2.59	2.73	2.74	2.74	2.74
		S/T	0.58	0.69	0.78	0.89	0.55	0.65	0.74	0.84	0.52	0.61	0.69	0.79	0.49	0.58	0.65	0.75
		PI	0.52	0.52	0.52	0.52	0.55	0.55	0.55	0.55	0.58	0.58	0.58	0.58	0.62	0.62	0.62	0.62
	35	TC	2.34	2.35	2.35	2.35	2.49	2.49	2.49	2.49	2.63	2.64	2.64	2.64	2.79	2.80	2.80	2.80
		S/T	0.64	0.75	0.85	0.97	0.60	0.71	0.81	0.92	0.57	0.67	0.76	0.87	0.54	0.63	0.72	0.82
		PI	0.67	0.68	0.68	0.68	0.72	0.72	0.72	0.72	0.76	0.76	0.76	0.76	0.80	0.80	0.81	0.81
	40	TC	2.03	2.03	2.04	2.04	2.15	2.16	2.16	2.16	2.28	2.29	2.29	2.29	2.42	2.42	2.43	2.43
		S/T	0.69	0.81	0.92	1.00	0.65	0.76	0.87	0.99	0.61	0.72	0.82	0.93	0.58	0.68	0.77	0.88
		PI	0.60	0.60	0.60	0.60	0.64	0.64	0.64	0.64	0.67	0.67	0.68	0.68	0.71	0.71	0.72	0.72
	45	TC	1.57	1.57	1.58	1.58	1.67	1.67	1.67	1.67	1.77	1.77	1.77	1.77	1.87	1.87	1.88	1.88
		S/T	0.73	0.86	0.98	1.00	0.69	0.81	0.92	1.00	0.65	0.77	0.87	0.99	0.62	0.72	0.82	0.94
		PI	0.49	0.49	0.49	0.49	0.52	0.52	0.52	0.52	0.55	0.55	0.55	0.56	0.59	0.59	0.59	0.59
	50	TC	0.89	0.89	0.89	0.89	0.94	0.94	0.94	0.95	1.00	1.00	1.00	1.00	1.06	1.06	1.06	1.06
		S/T	0.75	0.88	1.00	1.00	0.73	0.86	0.98	1.00	0.69	0.81	0.92	1.00	0.65	0.76	0.87	0.99
		PI	0.34	0.34	0.34	0.34	0.36	0.36	0.36	0.36	0.38	0.38	0.38	0.38	0.40	0.40	0.40	0.40

TC:Total Cooling Capacity (kW)

S/T:Sensible Cooling Capacity Ratio

PI:Power Input(kW)

Note: The table shows the case where the operation frequency of a compressor is fixed.

EF-12RD1H+MX1-12RD1H																		
INDOOR AIRFLOW (CMH)	OUTDOOR DB(°C)	ID WB (°C)	16.0				18.0				19.0				22.0			
		ID DB (°C)	23.0	25.0	27.0	29.0	23.0	25.0	27.0	29.0	23.0	25.0	27.0	29.0	23.0	25.0	27.0	29.0
600	-15	TC	3.85	3.85	3.86	3.86	4.08	4.08	4.09	4.09	4.32	4.33	4.33	4.34	4.58	4.59	4.59	4.60
		S/T	0.63	0.74	0.84	0.96	0.60	0.70	0.80	0.91	0.56	0.66	0.75	0.86	0.53	0.62	0.71	0.81
		PI	0.58	0.58	0.58	0.58	0.61	0.61	0.61	0.61	0.65	0.65	0.65	0.65	0.69	0.69	0.69	0.69
	-10	TC	3.63	3.64	3.64	3.65	3.85	3.86	3.86	3.86	4.08	4.09	4.09	4.10	4.33	4.33	4.34	4.34
		S/T	0.62	0.73	0.83	0.94	0.59	0.69	0.78	0.89	0.55	0.65	0.74	0.84	0.52	0.61	0.69	0.79
		PI	0.56	0.56	0.56	0.56	0.59	0.59	0.59	0.59	0.62	0.63	0.63	0.63	0.66	0.66	0.66	0.66
	-5	TC	3.55	3.55	3.56	3.56	3.76	3.77	3.77	3.78	3.99	3.99	4.00	4.00	4.23	4.23	4.24	4.24
		S/T	0.61	0.72	0.81	0.93	0.58	0.68	0.77	0.88	0.54	0.64	0.72	0.83	0.51	0.60	0.68	0.78
		PI	0.53	0.53	0.53	0.53	0.56	0.56	0.56	0.56	0.60	0.60	0.60	0.60	0.63	0.63	0.63	0.63
	0	TC	3.53	3.54	3.54	3.54	3.74	3.75	3.75	3.76	3.97	3.97	3.98	3.98	4.21	4.21	4.22	4.22
		S/T	0.60	0.71	0.80	0.91	0.57	0.67	0.76	0.86	0.54	0.63	0.71	0.81	0.50	0.59	0.67	0.77
		PI	0.50	0.50	0.50	0.50	0.53	0.53	0.53	0.53	0.56	0.57	0.57	0.57	0.60	0.60	0.60	0.60
	5	TC	3.33	3.33	3.34	3.34	3.53	3.53	3.54	3.54	3.74	3.74	3.75	3.75	3.97	3.97	3.97	3.98
		S/T	0.61	0.72	0.82	0.93	0.58	0.68	0.77	0.88	0.54	0.64	0.73	0.83	0.51	0.60	0.69	0.78
		PI	0.46	0.46	0.46	0.46	0.49	0.49	0.49	0.49	0.52	0.52	0.52	0.52	0.55	0.55	0.55	0.55
	10	TC	3.12	3.12	3.13	3.13	3.31	3.31	3.31	3.32	3.51	3.51	3.51	3.52	3.72	3.72	3.72	3.73
		S/T	0.62	0.73	0.82	0.94	0.58	0.68	0.78	0.89	0.55	0.65	0.73	0.84	0.52	0.61	0.69	0.79
		PI	0.44	0.44	0.44	0.44	0.47	0.47	0.47	0.47	0.50	0.50	0.50	0.50	0.53	0.53	0.53	0.53
	15	TC	3.08	3.09	3.09	3.09	3.27	3.27	3.28	3.28	3.46	3.47	3.47	3.48	3.67	3.68	3.68	3.69
		S/T	0.60	0.70	0.80	0.91	0.56	0.66	0.75	0.86	0.53	0.62	0.71	0.81	0.50	0.59	0.67	0.76
		PI	0.49	0.49	0.49	0.49	0.51	0.52	0.52	0.52	0.55	0.55	0.55	0.55	0.58	0.58	0.58	0.58
	20	TC	3.05	3.05	3.05	3.06	3.23	3.23	3.24	3.24	3.42	3.43	3.43	3.44	3.63	3.63	3.64	3.64
		S/T	0.58	0.68	0.77	0.88	0.54	0.64	0.72	0.83	0.51	0.60	0.68	0.78	0.48	0.57	0.65	0.74
		PI	0.53	0.53	0.53	0.53	0.56	0.56	0.56	0.56	0.59	0.60	0.60	0.60	0.63	0.63	0.63	0.63
	25	TC	3.01	3.01	3.02	3.02	3.19	3.19	3.20	3.20	3.38	3.39	3.39	3.39	3.58	3.59	3.59	3.60
		S/T	0.55	0.65	0.74	0.84	0.52	0.61	0.70	0.80	0.49	0.58	0.66	0.75	0.47	0.55	0.62	0.71
		PI	0.57	0.57	0.57	0.58	0.61	0.61	0.61	0.61	0.64	0.65	0.65	0.65	0.68	0.68	0.68	0.69
	30	TC	3.04	3.04	3.05	3.05	3.22	3.23	3.23	3.24	3.42	3.42	3.42	3.43	3.62	3.63	3.63	3.64
		S/T	0.58	0.69	0.78	0.89	0.55	0.65	0.74	0.84	0.52	0.61	0.69	0.79	0.49	0.58	0.65	0.75
		PI	0.74	0.74	0.74	0.74	0.78	0.78	0.78	0.78	0.83	0.83	0.83	0.83	0.88	0.88	0.88	0.88
	35	TC	3.11	3.11	3.11	3.12	3.29	3.30	3.30	3.31	3.49	3.50	3.50	3.50	3.70	3.71	3.71	3.72
		S/T	0.64	0.75	0.85	0.97	0.60	0.71	0.81	0.92	0.57	0.67	0.76	0.87	0.54	0.63	0.72	0.82
		PI	0.96	0.96	0.96	0.96	1.02	1.02	1.02	1.02	1.08	1.08	1.08	1.08	1.14	1.14	1.14	1.15
	40	TC	2.69	2.70	2.70	2.70	2.86	2.86	2.86	2.87	3.03	3.03	3.03	3.04	3.21	3.21	3.22	3.22
		S/T	0.69	0.81	0.92	1.00	0.65	0.76	0.87	0.99	0.61	0.72	0.82	0.93	0.58	0.68	0.77	0.88
		PI	0.85	0.85	0.85	0.86	0.90	0.90	0.91	0.91	0.96	0.96	0.96	0.96	1.01	1.02	1.02	1.02
	45	TC	2.08	2.09	2.09	2.09	2.21	2.21	2.21	2.22	2.34	2.34	2.35	2.35	2.48	2.49	2.49	2.49
		S/T	0.73	0.86	0.98	1.00	0.69	0.81	0.92	1.00	0.65	0.77	0.87	0.99	0.62	0.72	0.82	0.94
		PI	0.70	0.70	0.70	0.70	0.74	0.74	0.74	0.74	0.79	0.79	0.79	0.79	0.83	0.83	0.84	0.84
	50	TC	1.18	1.18	1.18	1.18	1.25	1.25	1.25	1.25	1.32	1.33	1.33	1.33	1.40	1.40	1.41	1.41
		S/T	0.75	0.88	1.00	1.00	0.73	0.86	0.98	1.00	0.69	0.81	0.92	1.00	0.65	0.76	0.87	0.99
		PI	0.48	0.48	0.48	0.48	0.51	0.51	0.51	0.51	0.54	0.54	0.54	0.54	0.57	0.57	0.57	0.57

TC:Total Cooling Capacity (kW)

S/T:Sensible Cooling Capacity Ratio

PI:Power Input(kW)

Note: The table shows the case where the operation frequency of a compressor is fixed.

EF-12RD1L+MX1-12RD1L																		
INDOOR AIRFLOW (CMH)	OUTDOOR DB(°C)	ID WB (°C)	16.0				18.0				19.0				22.0			
		ID DB (°C)	23.0	25.0	27.0	29.0	23.0	25.0	27.0	29.0	23.0	25.0	27.0	29.0	23.0	25.0	27.0	29.0
590	-15	TC	3.85	3.85	3.86	3.86	4.08	4.08	4.09	4.09	4.32	4.33	4.33	4.34	4.58	4.59	4.59	4.60
		S/T	0.63	0.74	0.84	0.96	0.60	0.70	0.80	0.91	0.56	0.66	0.75	0.86	0.53	0.62	0.71	0.81
		PI	0.72	0.72	0.72	0.72	0.76	0.76	0.77	0.77	0.81	0.81	0.81	0.81	0.86	0.86	0.86	0.86
	-10	TC	3.63	3.64	3.64	3.65	3.85	3.86	3.86	3.86	4.08	4.09	4.09	4.10	4.33	4.33	4.34	4.34
		S/T	0.62	0.73	0.83	0.94	0.59	0.69	0.78	0.89	0.55	0.65	0.74	0.84	0.52	0.61	0.69	0.79
		PI	0.69	0.70	0.70	0.70	0.74	0.74	0.74	0.74	0.78	0.78	0.78	0.78	0.83	0.83	0.83	0.83
	-5	TC	3.55	3.55	3.56	3.56	3.76	3.77	3.77	3.78	3.99	3.99	4.00	4.00	4.23	4.23	4.24	4.24
		S/T	0.61	0.72	0.81	0.93	0.58	0.68	0.77	0.88	0.54	0.64	0.72	0.83	0.51	0.60	0.68	0.78
		PI	0.66	0.66	0.66	0.67	0.70	0.70	0.70	0.71	0.75	0.75	0.75	0.75	0.79	0.79	0.79	0.79
	0	TC	3.53	3.54	3.54	3.54	3.74	3.75	3.75	3.76	3.97	3.97	3.98	3.98	4.21	4.21	4.22	4.22
		S/T	0.60	0.71	0.80	0.91	0.57	0.67	0.76	0.86	0.54	0.63	0.71	0.81	0.50	0.59	0.67	0.77
		PI	0.63	0.63	0.63	0.63	0.67	0.67	0.67	0.67	0.71	0.71	0.71	0.71	0.75	0.75	0.75	0.75
	5	TC	3.33	3.33	3.34	3.34	3.53	3.53	3.54	3.54	3.74	3.74	3.75	3.75	3.97	3.97	3.97	3.98
		S/T	0.61	0.72	0.82	0.93	0.58	0.68	0.77	0.88	0.54	0.64	0.73	0.83	0.51	0.60	0.69	0.78
		PI	0.58	0.58	0.58	0.58	0.61	0.61	0.61	0.61	0.65	0.65	0.65	0.65	0.69	0.69	0.69	0.69
	10	TC	3.12	3.12	3.13	3.13	3.31	3.31	3.31	3.32	3.51	3.51	3.51	3.52	3.72	3.72	3.72	3.73
		S/T	0.62	0.73	0.82	0.94	0.58	0.68	0.78	0.89	0.55	0.65	0.73	0.84	0.52	0.61	0.69	0.79
		PI	0.55	0.55	0.55	0.55	0.58	0.59	0.59	0.59	0.62	0.62	0.62	0.62	0.66	0.66	0.66	0.66
	15	TC	3.08	3.09	3.09	3.09	3.27	3.27	3.28	3.28	3.46	3.47	3.47	3.48	3.67	3.68	3.68	3.69
		S/T	0.60	0.70	0.80	0.91	0.56	0.66	0.75	0.86	0.53	0.62	0.71	0.81	0.50	0.59	0.67	0.76
		PI	0.61	0.61	0.61	0.61	0.64	0.64	0.64	0.65	0.68	0.68	0.68	0.68	0.72	0.72	0.72	0.73
	20	TC	3.05	3.05	3.05	3.06	3.23	3.23	3.24	3.24	3.42	3.43	3.43	3.44	3.63	3.63	3.64	3.64
		S/T	0.58	0.68	0.77	0.88	0.54	0.64	0.72	0.83	0.51	0.60	0.68	0.78	0.48	0.57	0.65	0.74
		PI	0.66	0.66	0.66	0.66	0.70	0.70	0.70	0.70	0.74	0.74	0.75	0.75	0.79	0.79	0.79	0.79
	25	TC	3.01	3.01	3.02	3.02	3.19	3.19	3.20	3.20	3.38	3.39	3.39	3.39	3.58	3.59	3.59	3.60
		S/T	0.55	0.65	0.74	0.84	0.52	0.61	0.70	0.80	0.49	0.58	0.66	0.75	0.47	0.55	0.62	0.71
		PI	0.72	0.72	0.72	0.72	0.76	0.76	0.76	0.76	0.81	0.81	0.81	0.81	0.85	0.85	0.86	0.86
	30	TC	3.04	3.04	3.05	3.05	3.22	3.23	3.23	3.24	3.42	3.42	3.42	3.43	3.62	3.63	3.63	3.64
		S/T	0.58	0.69	0.78	0.89	0.55	0.65	0.74	0.84	0.52	0.61	0.69	0.79	0.49	0.58	0.65	0.75
		PI	0.92	0.92	0.92	0.92	0.97	0.98	0.98	0.98	1.03	1.03	1.04	1.04	1.10	1.10	1.10	1.10
	35	TC	3.11	3.11	3.11	3.12	3.29	3.30	3.30	3.31	3.49	3.50	3.50	3.50	3.70	3.71	3.71	3.72
		S/T	0.64	0.75	0.85	0.97	0.60	0.71	0.81	0.92	0.57	0.67	0.76	0.87	0.54	0.63	0.72	0.82
		PI	1.20	1.20	1.20	1.20	1.27	1.27	1.27	1.28	1.35	1.35	1.35	1.35	1.43	1.43	1.43	1.43
	40	TC	2.69	2.70	2.70	2.70	2.86	2.86	2.86	2.87	3.03	3.03	3.03	3.04	3.21	3.21	3.22	3.22
		S/T	0.69	0.81	0.92	1.00	0.65	0.76	0.87	0.99	0.61	0.72	0.82	0.93	0.58	0.68	0.77	0.88
		PI	1.06	1.07	1.07	1.07	1.13	1.13	1.13	1.13	1.20	1.20	1.20	1.20	1.27	1.27	1.27	1.27
	45	TC	2.08	2.09	2.09	2.09	2.21	2.21	2.21	2.22	2.34	2.34	2.35	2.35	2.48	2.49	2.49	2.49
		S/T	0.73	0.86	0.98	1.00	0.69	0.81	0.92	1.00	0.65	0.77	0.87	0.99	0.62	0.72	0.82	0.94
		PI	0.87	0.88	0.88	0.88	0.93	0.93	0.93	0.93	0.98	0.98	0.99	0.99	1.04	1.04	1.04	1.05
	50	TC	1.18	1.18	1.18	1.18	1.25	1.25	1.25	1.25	1.32	1.33	1.33	1.33	1.40	1.40	1.41	1.41
		S/T	0.75	0.88	1.00	1.00	0.73	0.86	0.98	1.00	0.69	0.81	0.92	1.00	0.65	0.76	0.87	0.99
		PI	0.60	0.60	0.60	0.60	0.64	0.64	0.64	0.64	0.68	0.68	0.68	0.68	0.72	0.72	0.72	0.72

TC:Total Cooling Capacity (kW)

S/T:Sensible Cooling Capacity Ratio

PI:Power Input(kW)

Note: The table shows the case where the operation frequency of a compressor is fixed.

EF-12RD1M+MX1-12RD1H																		
INDOOR AIRFLOW (CMH)	OUTDOOR DB(°C)	ID WB (°C)	16.0				18.0				19.0				22.0			
		ID DB (°C)	23.0	25.0	27.0	29.0	23.0	25.0	27.0	29.0	23.0	25.0	27.0	29.0	23.0	25.0	27.0	29.0
600	-15	TC	3.85	3.85	3.86	3.86	4.08	4.08	4.09	4.09	4.32	4.33	4.33	4.34	4.58	4.59	4.59	4.60
		S/T	0.63	0.74	0.84	0.96	0.60	0.70	0.80	0.91	0.56	0.66	0.75	0.86	0.53	0.62	0.71	0.81
		PI	0.64	0.64	0.64	0.64	0.68	0.68	0.68	0.68	0.72	0.72	0.72	0.72	0.76	0.76	0.76	0.77
	-10	TC	3.63	3.64	3.64	3.65	3.85	3.86	3.86	3.86	4.08	4.09	4.09	4.10	4.33	4.33	4.34	4.34
		S/T	0.62	0.73	0.83	0.94	0.59	0.69	0.78	0.89	0.55	0.65	0.74	0.84	0.52	0.61	0.69	0.79
		PI	0.62	0.62	0.62	0.62	0.65	0.66	0.66	0.66	0.69	0.69	0.70	0.70	0.74	0.74	0.74	0.74
	-5	TC	3.55	3.55	3.56	3.56	3.76	3.77	3.77	3.78	3.99	3.99	4.00	4.00	4.23	4.23	4.24	4.24
		S/T	0.61	0.72	0.81	0.93	0.58	0.68	0.77	0.88	0.54	0.64	0.72	0.83	0.51	0.60	0.68	0.78
		PI	0.59	0.59	0.59	0.59	0.62	0.63	0.63	0.63	0.66	0.66	0.66	0.66	0.70	0.70	0.70	0.70
	0	TC	3.53	3.54	3.54	3.54	3.74	3.75	3.75	3.76	3.97	3.97	3.98	3.98	4.21	4.21	4.22	4.22
		S/T	0.60	0.71	0.80	0.91	0.57	0.67	0.76	0.86	0.54	0.63	0.71	0.81	0.50	0.59	0.67	0.77
		PI	0.56	0.56	0.56	0.56	0.59	0.59	0.59	0.59	0.63	0.63	0.63	0.63	0.67	0.67	0.67	0.67
	5	TC	3.33	3.33	3.34	3.34	3.53	3.53	3.54	3.54	3.74	3.74	3.75	3.75	3.97	3.97	3.97	3.98
		S/T	0.61	0.72	0.82	0.93	0.58	0.68	0.77	0.88	0.54	0.64	0.73	0.83	0.51	0.60	0.69	0.78
		PI	0.51	0.51	0.51	0.51	0.54	0.54	0.54	0.54	0.57	0.58	0.58	0.58	0.61	0.61	0.61	0.61
	10	TC	3.12	3.12	3.13	3.13	3.31	3.31	3.31	3.32	3.51	3.51	3.51	3.52	3.72	3.72	3.72	3.73
		S/T	0.62	0.73	0.82	0.94	0.58	0.68	0.78	0.89	0.55	0.65	0.73	0.84	0.52	0.61	0.69	0.79
		PI	0.49	0.49	0.49	0.49	0.52	0.52	0.52	0.52	0.55	0.55	0.55	0.55	0.58	0.58	0.59	0.59
	15	TC	3.08	3.09	3.09	3.09	3.27	3.27	3.28	3.28	3.46	3.47	3.47	3.48	3.67	3.68	3.68	3.69
		S/T	0.60	0.70	0.80	0.91	0.56	0.66	0.75	0.86	0.53	0.62	0.71	0.81	0.50	0.59	0.67	0.76
		PI	0.54	0.54	0.54	0.54	0.57	0.57	0.57	0.57	0.61	0.61	0.61	0.61	0.64	0.64	0.64	0.64
	20	TC	3.05	3.05	3.05	3.06	3.23	3.23	3.24	3.24	3.42	3.43	3.43	3.44	3.63	3.63	3.64	3.64
		S/T	0.58	0.68	0.77	0.88	0.54	0.64	0.72	0.83	0.51	0.60	0.68	0.78	0.48	0.57	0.65	0.74
		PI	0.59	0.59	0.59	0.59	0.62	0.62	0.62	0.63	0.66	0.66	0.66	0.66	0.70	0.70	0.70	0.70
	25	TC	3.01	3.01	3.02	3.02	3.19	3.19	3.20	3.20	3.38	3.39	3.39	3.39	3.58	3.59	3.59	3.60
		S/T	0.55	0.65	0.74	0.84	0.52	0.61	0.70	0.80	0.49	0.58	0.66	0.75	0.47	0.55	0.62	0.71
		PI	0.64	0.64	0.64	0.64	0.68	0.68	0.68	0.68	0.72	0.72	0.72	0.72	0.76	0.76	0.76	0.76
	30	TC	3.04	3.04	3.05	3.05	3.22	3.23	3.23	3.24	3.42	3.42	3.42	3.43	3.62	3.63	3.63	3.64
		S/T	0.58	0.69	0.78	0.89	0.55	0.65	0.74	0.84	0.52	0.61	0.69	0.79	0.49	0.58	0.65	0.75
		PI	0.82	0.82	0.82	0.82	0.87	0.87	0.87	0.87	0.92	0.92	0.92	0.92	0.97	0.97	0.98	0.98
	35	TC	3.11	3.11	3.11	3.12	3.29	3.30	3.30	3.31	3.49	3.50	3.50	3.50	3.70	3.71	3.71	3.72
		S/T	0.64	0.75	0.85	0.97	0.60	0.71	0.81	0.92	0.57	0.67	0.76	0.87	0.54	0.63	0.72	0.82
		PI	1.07	1.07	1.07	1.07	1.13	1.13	1.13	1.13	1.20	1.20	1.20	1.20	1.27	1.27	1.27	1.27
	40	TC	2.69	2.70	2.70	2.70	2.86	2.86	2.86	2.87	3.03	3.03	3.03	3.04	3.21	3.21	3.22	3.22
		S/T	0.69	0.81	0.92	1.00	0.65	0.76	0.87	0.99	0.61	0.72	0.82	0.93	0.58	0.68	0.77	0.88
		PI	0.95	0.95	0.95	0.95	1.00	1.00	1.01	1.01	1.06	1.06	1.07	1.07	1.13	1.13	1.13	1.13
	45	TC	2.08	2.09	2.09	2.09	2.21	2.21	2.21	2.22	2.34	2.34	2.35	2.35	2.48	2.49	2.49	2.49
		S/T	0.73	0.86	0.98	1.00	0.69	0.81	0.92	1.00	0.65	0.77	0.87	0.99	0.62	0.72	0.82	0.94
		PI	0.78	0.78	0.78	0.78	0.82	0.83	0.83	0.83	0.87	0.88	0.88	0.88	0.93	0.93	0.93	0.93
	50	TC	1.18	1.18	1.18	1.18	1.25	1.25	1.25	1.25	1.32	1.33	1.33	1.33	1.40	1.40	1.41	1.41
		S/T	0.75	0.88	1.00	1.00	0.73	0.86	0.98	1.00	0.69	0.81	0.92	1.00	0.65	0.76	0.87	0.99
		PI	0.53	0.53	0.54	0.54	0.57	0.57	0.57	0.57	0.60	0.60	0.60	0.60	0.64	0.64	0.64	0.64

TC:Total Cooling Capacity (kW)

S/T:Sensible Cooling Capacity Ratio

PI:Power Input(kW)

Note: The table shows the case where the operation frequency of a compressor is fixed.

EF-18RD1+MX3-18RD1-EF																		
INDOOR AIRFLOW (CMH)	OUTDOOR DB(°C)	ID WB (°C)	16.0				18.0				19.0				22.0			
		ID DB (°C)	23.0	25.0	27.0	29.0	23.0	25.0	27.0	29.0	23.0	25.0	27.0	29.0	23.0	25.0	27.0	29.0
800	-15	TC	5.72	5.72	5.73	5.74	6.06	6.07	6.07	6.08	6.42	6.43	6.44	6.45	6.81	6.82	6.82	6.83
		S/T	0.63	0.74	0.84	0.96	0.60	0.70	0.80	0.91	0.56	0.66	0.75	0.86	0.53	0.62	0.71	0.81
		PI	0.85	0.85	0.86	0.86	0.91	0.91	0.91	0.91	0.96	0.96	0.96	0.96	1.02	1.02	1.02	1.02
	-10	TC	5.40	5.40	5.41	5.42	5.72	5.73	5.73	5.74	6.06	6.07	6.08	6.09	6.43	6.43	6.44	6.45
		S/T	0.62	0.73	0.83	0.94	0.59	0.69	0.78	0.89	0.55	0.65	0.74	0.84	0.52	0.61	0.69	0.79
		PI	0.82	0.82	0.83	0.83	0.87	0.87	0.87	0.88	0.93	0.93	0.93	0.93	0.98	0.98	0.98	0.98
	-5	TC	5.27	5.28	5.28	5.29	5.59	5.60	5.60	5.61	5.92	5.93	5.94	5.95	6.28	6.29	6.29	6.30
		S/T	0.61	0.72	0.81	0.93	0.58	0.68	0.77	0.88	0.54	0.64	0.72	0.83	0.51	0.60	0.68	0.78
		PI	0.79	0.79	0.79	0.79	0.83	0.83	0.84	0.84	0.88	0.88	0.89	0.89	0.94	0.94	0.94	0.94
	0	TC	5.25	5.25	5.26	5.27	5.56	5.57	5.57	5.58	5.89	5.90	5.91	5.92	6.25	6.26	6.26	6.27
		S/T	0.60	0.71	0.80	0.91	0.57	0.67	0.76	0.86	0.54	0.63	0.71	0.81	0.50	0.59	0.67	0.77
		PI	0.74	0.75	0.75	0.75	0.79	0.79	0.79	0.79	0.84	0.84	0.84	0.84	0.89	0.89	0.89	0.89
	5	TC	4.94	4.95	4.96	4.96	5.24	5.25	5.25	5.26	5.56	5.56	5.57	5.58	5.89	5.90	5.90	5.91
		S/T	0.61	0.72	0.82	0.93	0.58	0.68	0.77	0.88	0.54	0.64	0.73	0.83	0.51	0.60	0.69	0.78
		PI	0.68	0.68	0.68	0.68	0.72	0.72	0.72	0.73	0.77	0.77	0.77	0.77	0.81	0.81	0.81	0.81
	10	TC	4.63	4.64	4.65	4.65	4.91	4.92	4.92	4.93	5.21	5.21	5.22	5.23	5.52	5.53	5.53	5.54
		S/T	0.62	0.73	0.82	0.94	0.58	0.68	0.78	0.89	0.55	0.65	0.73	0.84	0.52	0.61	0.69	0.79
		PI	0.65	0.65	0.66	0.66	0.69	0.69	0.69	0.70	0.73	0.74	0.74	0.74	0.78	0.78	0.78	0.78
	15	TC	4.58	4.59	4.59	4.60	4.86	4.86	4.87	4.87	5.15	5.15	5.16	5.17	5.46	5.46	5.47	5.48
		S/T	0.60	0.70	0.80	0.91	0.56	0.66	0.75	0.86	0.53	0.62	0.71	0.81	0.50	0.59	0.67	0.76
		PI	0.72	0.72	0.72	0.72	0.76	0.76	0.76	0.76	0.81	0.81	0.81	0.81	0.86	0.86	0.86	0.86
	20	TC	4.53	4.53	4.54	4.54	4.80	4.80	4.81	4.82	5.08	5.09	5.10	5.10	5.39	5.40	5.40	5.41
		S/T	0.58	0.68	0.77	0.88	0.54	0.64	0.72	0.83	0.51	0.60	0.68	0.78	0.48	0.57	0.65	0.74
		PI	0.78	0.79	0.79	0.79	0.83	0.83	0.83	0.83	0.88	0.88	0.88	0.88	0.93	0.94	0.94	0.94
	25	TC	4.47	4.48	4.48	4.49	4.74	4.75	4.75	4.76	5.02	5.03	5.04	5.04	5.33	5.33	5.34	5.34
		S/T	0.55	0.65	0.74	0.84	0.52	0.61	0.70	0.80	0.49	0.58	0.66	0.75	0.47	0.55	0.62	0.71
		PI	0.85	0.85	0.85	0.85	0.90	0.90	0.90	0.90	0.95	0.96	0.96	0.96	1.01	1.01	1.01	1.02
	30	TC	4.52	4.52	4.53	4.53	4.79	4.80	4.80	4.81	5.08	5.08	5.09	5.09	5.38	5.39	5.39	5.40
		S/T	0.58	0.69	0.78	0.89	0.55	0.65	0.74	0.84	0.52	0.61	0.69	0.79	0.49	0.58	0.65	0.75
		PI	1.09	1.09	1.09	1.09	1.16	1.16	1.16	1.16	1.22	1.23	1.23	1.23	1.30	1.30	1.30	1.30
	35	TC	4.62	4.62	4.63	4.63	4.89	4.90	4.91	4.91	5.19	5.19	5.20	5.21	5.50	5.51	5.51	5.52
		S/T	0.64	0.75	0.85	0.97	0.60	0.71	0.81	0.92	0.57	0.67	0.76	0.87	0.54	0.63	0.72	0.82
		PI	1.42	1.42	1.42	1.43	1.51	1.51	1.51	1.51	1.60	1.60	1.60	1.60	1.69	1.69	1.70	1.70
	40	TC	4.00	4.01	4.01	4.02	4.24	4.25	4.25	4.26	4.50	4.50	4.51	4.51	4.77	4.77	4.78	4.79
		S/T	0.69	0.81	0.92	1.00	0.65	0.76	0.87	0.99	0.61	0.72	0.82	0.93	0.58	0.68	0.77	0.88
		PI	1.26	1.26	1.27	1.27	1.34	1.34	1.34	1.34	1.42	1.42	1.42	1.42	1.50	1.51	1.51	1.51
	45	TC	3.10	3.10	3.10	3.11	3.28	3.29	3.29	3.29	3.48	3.48	3.49	3.49	3.69	3.69	3.70	3.70
		S/T	0.73	0.86	0.98	1.00	0.69	0.81	0.92	1.00	0.65	0.77	0.87	0.99	0.62	0.72	0.82	0.94
		PI	1.04	1.04	1.04	1.04	1.10	1.10	1.10	1.10	1.17	1.17	1.17	1.17	1.24	1.24	1.24	1.24
	50	TC	1.75	1.75	1.75	1.76	1.86	1.86	1.86	1.86	1.97	1.97	1.97	1.97	2.09	2.09	2.09	2.09
		S/T	0.75	0.88	1.00	1.00	0.73	0.86	0.98	1.00	0.69	0.81	0.92	1.00	0.65	0.76	0.87	0.99
		PI	0.71	0.71	0.71	0.72	0.76	0.76	0.76	0.76	0.80	0.80	0.80	0.80	0.85	0.85	0.85	0.85

TC:Total Cooling Capacity (kW)

S/T:Sensible Cooling Capacity Ratio

PI:Power Input(kW)

Note: The table shows the case where the operation frequency of a compressor is fixed.

EF-24RD1+MX4-24RD1-EF																		
INDOOR AIRFLOW (CMH)	OUTDOOR DB(°C)	ID WB (°C)	16.0				18.0				19.0				22.0			
		ID DB (°C)	23.0	25.0	27.0	29.0	23.0	25.0	27.0	29.0	23.0	25.0	27.0	29.0	23.0	25.0	27.0	29.0
1050	-15	TC	7.69	7.70	7.71	7.72	8.16	8.17	8.18	8.19	8.65	8.66	8.67	8.68	9.17	9.18	9.19	9.20
		S/T	0.63	0.74	0.84	0.96	0.60	0.70	0.80	0.91	0.56	0.66	0.75	0.86	0.53	0.62	0.71	0.81
		PI	1.39	1.39	1.39	1.39	1.47	1.47	1.47	1.48	1.56	1.56	1.56	1.56	1.65	1.65	1.66	1.66
	-10	TC	7.26	7.27	7.28	7.29	7.70	7.71	7.72	7.73	8.16	8.17	8.18	8.19	8.65	8.66	8.67	8.68
		S/T	0.62	0.73	0.83	0.94	0.59	0.69	0.78	0.89	0.55	0.65	0.74	0.84	0.52	0.61	0.69	0.79
		PI	1.34	1.34	1.34	1.34	1.42	1.42	1.42	1.42	1.50	1.51	1.51	1.51	1.59	1.60	1.60	1.60
	-5	TC	7.10	7.11	7.11	7.12	7.52	7.53	7.54	7.55	7.97	7.98	7.99	8.00	8.45	8.46	8.47	8.48
		S/T	0.61	0.72	0.81	0.93	0.58	0.68	0.77	0.88	0.54	0.64	0.72	0.83	0.51	0.60	0.68	0.78
		PI	1.28	1.28	1.28	1.28	1.35	1.36	1.36	1.36	1.43	1.44	1.44	1.44	1.52	1.52	1.52	1.53
	0	TC	7.06	7.07	7.08	7.09	7.49	7.50	7.50	7.51	7.93	7.94	7.95	7.96	8.41	8.42	8.43	8.44
		S/T	0.60	0.71	0.80	0.91	0.57	0.67	0.76	0.86	0.54	0.63	0.71	0.81	0.50	0.59	0.67	0.77
		PI	1.21	1.21	1.21	1.22	1.28	1.28	1.29	1.29	1.36	1.36	1.36	1.37	1.44	1.44	1.45	1.45
	5	TC	6.66	6.67	6.67	6.68	7.06	7.07	7.07	7.08	7.48	7.49	7.50	7.51	7.93	7.94	7.95	7.96
		S/T	0.61	0.72	0.82	0.93	0.58	0.68	0.77	0.88	0.54	0.64	0.73	0.83	0.51	0.60	0.69	0.78
		PI	1.11	1.11	1.11	1.11	1.17	1.18	1.18	1.18	1.24	1.25	1.25	1.25	1.32	1.32	1.32	1.32
	10	TC	6.24	6.25	6.25	6.26	6.62	6.62	6.63	6.64	7.01	7.02	7.03	7.04	7.43	7.44	7.45	7.46
		S/T	0.62	0.73	0.82	0.94	0.58	0.68	0.78	0.89	0.55	0.65	0.73	0.84	0.52	0.61	0.69	0.79
		PI	1.06	1.06	1.06	1.07	1.13	1.13	1.13	1.13	1.19	1.20	1.20	1.20	1.27	1.27	1.27	1.27
	15	TC	6.17	6.17	6.18	6.19	6.54	6.54	6.55	6.56	6.93	6.94	6.94	6.95	7.35	7.35	7.36	7.37
		S/T	0.60	0.70	0.80	0.91	0.56	0.66	0.75	0.86	0.53	0.62	0.71	0.81	0.50	0.59	0.67	0.76
		PI	1.17	1.17	1.17	1.17	1.24	1.24	1.24	1.24	1.31	1.31	1.32	1.32	1.39	1.39	1.39	1.40
	20	TC	6.09	6.10	6.11	6.12	6.46	6.47	6.47	6.48	6.84	6.85	6.86	6.87	7.26	7.27	7.27	7.28
		S/T	0.58	0.68	0.77	0.88	0.54	0.64	0.72	0.83	0.51	0.60	0.68	0.78	0.48	0.57	0.65	0.74
		PI	1.27	1.28	1.28	1.28	1.35	1.35	1.35	1.36	1.43	1.43	1.44	1.44	1.52	1.52	1.52	1.52
	25	TC	6.02	6.03	6.03	6.04	6.38	6.39	6.39	6.40	6.76	6.77	6.78	6.79	7.17	7.18	7.19	7.20
		S/T	0.55	0.65	0.74	0.84	0.52	0.61	0.70	0.80	0.49	0.58	0.66	0.75	0.47	0.55	0.62	0.71
		PI	1.38	1.38	1.38	1.39	1.46	1.47	1.47	1.47	1.55	1.55	1.55	1.56	1.64	1.65	1.65	1.65
	30	TC	6.08	6.09	6.10	6.10	6.45	6.46	6.46	6.47	6.83	6.84	6.85	6.86	7.24	7.25	7.26	7.27
		S/T	0.58	0.69	0.78	0.89	0.55	0.65	0.74	0.84	0.52	0.61	0.69	0.79	0.49	0.58	0.65	0.75
		PI	1.77	1.77	1.78	1.78	1.88	1.88	1.88	1.88	1.99	1.99	1.99	2.00	2.11	2.11	2.11	2.12
	35	TC	6.21	6.22	6.23	6.24	6.59	6.60	6.60	6.61	6.98	6.99	7.00	7.01	7.40	7.41	7.42	7.43
		S/T	0.64	0.75	0.85	0.97	0.60	0.71	0.81	0.92	0.57	0.67	0.76	0.87	0.54	0.63	0.72	0.82
		PI	2.31	2.31	2.31	2.32	2.45	2.45	2.45	2.46	2.59	2.60	2.60	2.60	2.75	2.75	2.76	2.76
	40	TC	5.39	5.40	5.40	5.41	5.71	5.72	5.73	5.73	6.05	6.06	6.07	6.08	6.42	6.43	6.43	6.44
		S/T	0.69	0.81	0.92	1.00	0.65	0.76	0.87	0.99	0.61	0.72	0.82	0.93	0.58	0.68	0.77	0.88
		PI	2.05	2.05	2.06	2.06	2.17	2.18	2.18	2.18	2.30	2.31	2.31	2.31	2.44	2.45	2.45	2.45
	45	TC	4.17	4.17	4.18	4.18	4.42	4.42	4.43	4.43	4.68	4.69	4.69	4.70	4.97	4.97	4.98	4.98
		S/T	0.73	0.86	0.98	1.00	0.69	0.81	0.92	1.00	0.65	0.77	0.87	0.99	0.62	0.72	0.82	0.94
		PI	1.69	1.69	1.69	1.69	1.79	1.79	1.79	1.79	1.89	1.90	1.90	1.90	2.01	2.01	2.01	2.01
	50	TC	2.36	2.36	2.36	2.37	2.50	2.50	2.50	2.51	2.65	2.65	2.65	2.66	2.81	2.81	2.81	2.82
		S/T	0.75	0.88	1.00	1.00	0.73	0.86	0.98	1.00	0.69	0.81	0.92	1.00	0.65	0.76	0.87	0.99
		PI	1.16	1.16	1.16	1.16	1.23	1.23	1.23	1.23	1.30	1.30	1.30	1.31	1.38	1.38	1.38	1.38

TC:Total Cooling Capacity (kW)

S/T:Sensible Cooling Capacity Ratio

PI:Power Input(kW)

Note: The table shows the case where the operation frequency of a compressor is fixed.

2.2 Heating

EF-07RD1+MX0-07RD1								[SI_Unit]	
INDOOR AIRFLOW (CMH)	OUTDOOR DB(°C)	HEATING PERFORMANCE AT INDOOR DRY BULB TEMPERATURE							
		TC:TOTAL CAPACITY IN KILOWATTS (KW)				PI:TOTAL POWER IN KILOWATTS (KW)			
		Indoor Conditions (DB °C)				Indoor Conditions (DB °C)			
		16.0	20.0	22.0	24.0	16.0	20.0	22.0	24.0
490	-20.0	1.33	1.31	1.31	1.29	0.35	0.36	0.37	0.38
	-15.0	1.44	1.42	1.42	1.39	0.38	0.39	0.41	0.42
	-10.0	1.54	1.51	1.51	1.49	0.41	0.42	0.43	0.44
	-7.0	1.61	1.58	1.58	1.56	0.43	0.44	0.46	0.47
	-5.6	1.70	1.67	1.67	1.64	0.44	0.46	0.47	0.49
	-2.8	1.79	1.76	1.76	1.73	0.47	0.49	0.51	0.52
	0.0	1.84	1.81	1.81	1.81	0.50	0.52	0.54	0.55
	2.8	1.99	1.96	1.96	1.93	0.53	0.56	0.57	0.59
	5.6	2.19	2.16	2.16	2.13	0.57	0.60	0.61	0.62
	7.0	2.43	2.40	2.34	2.31	0.59	0.64	0.63	0.64
	11.1	2.57	2.54	2.52	2.52	0.63	0.66	0.68	0.70
	13.9	2.72	2.69	2.66	2.63	0.67	0.70	0.71	0.73
	16.7	2.86	2.80	2.80	2.78	0.70	0.73	0.75	0.76
18.0	2.92	2.89	2.86	2.83	0.71	0.75	0.76	0.78	

Note: The table shows the case where the operation frequency of a compressor is fixed.

EF-09RD1L+MX1-09RD1H								[SI_Unit]	
INDOOR AIRFLOW (CMH)	OUTDOOR DB(°C)	HEATING PERFORMANCE AT INDOOR DRY BULB TEMPERATURE							
		TC:TOTAL CAPACITY IN KILOWATTS (KW)				PI:TOTAL POWER IN KILOWATTS (KW)			
		Indoor Conditions (DB °C)				Indoor Conditions (DB °C)			
		16.0	20.0	22.0	24.0	16.0	20.0	22.0	24.0
510	-20.0	1.62	1.60	1.57	1.57	0.43	0.44	0.46	0.47
	-15.0	1.75	1.73	1.70	1.70	0.47	0.48	0.51	0.52
	-10.0	1.87	1.85	1.82	1.82	0.50	0.51	0.54	0.55
	-7.0	1.96	1.93	1.91	1.91	0.54	0.55	0.57	0.58
	-5.6	2.08	2.05	2.02	2.02	0.55	0.57	0.58	0.60
	-2.8	2.19	2.16	2.14	2.14	0.58	0.61	0.62	0.64
	0.0	2.25	2.22	2.22	2.19	0.61	0.64	0.66	0.68
	2.8	2.42	2.40	2.37	2.37	0.66	0.69	0.71	0.72
	5.6	2.68	2.66	2.63	2.60	0.70	0.73	0.75	0.77
	7.0	2.96	2.93	2.84	2.81	0.72	0.79	0.78	0.80
	11.1	3.13	3.10	3.08	3.08	0.78	0.82	0.84	0.86
	13.9	3.31	3.28	3.25	3.22	0.82	0.86	0.88	0.90
	16.7	3.48	3.42	3.42	3.39	0.86	0.90	0.92	0.95
18.0	3.57	3.51	3.48	3.48	0.88	0.92	0.94	0.97	

Note: The table shows the case where the operation frequency of a compressor is fixed.

EF-09RD1H+MX1-09RD1H								[SI_Unit]	
INDOOR AIRFLOW (CMH)	HEATING PERFORMANCE AT INDOOR DRY BULB TEMPERATURE								
	OUTDOOR DB(°C)	TC:TOTAL CAPACITY IN KILOWATTS (KW)				PI:TOTAL POWER IN KILOWATTS (KW)			
		Indoor Conditions (DB °C)				Indoor Conditions (DB °C)			
		16.0	20.0	22.0	24.0	16.0	20.0	22.0	24.0
510	-20.0	1.62	1.60	1.57	1.57	0.40	0.41	0.42	0.44
	-15.0	1.75	1.73	1.70	1.70	0.44	0.44	0.46	0.48
	-10.0	1.87	1.85	1.82	1.82	0.46	0.47	0.49	0.51
	-7.0	1.96	1.93	1.91	1.91	0.49	0.50	0.52	0.54
	-5.6	2.08	2.05	2.02	2.02	0.50	0.53	0.54	0.55
	-2.8	2.19	2.16	2.14	2.14	0.54	0.56	0.58	0.59
	0.0	2.25	2.22	2.22	2.19	0.57	0.60	0.61	0.62
	2.8	2.42	2.40	2.37	2.37	0.61	0.64	0.65	0.67
	5.6	2.68	2.66	2.63	2.60	0.65	0.68	0.70	0.71
	7.0	2.96	2.93	2.84	2.81	0.67	0.73	0.72	0.74
	11.1	3.13	3.10	3.08	3.08	0.72	0.76	0.78	0.79
	13.9	3.31	3.28	3.25	3.22	0.76	0.80	0.81	0.83
	16.7	3.48	3.42	3.42	3.39	0.80	0.83	0.85	0.87
18.0	3.57	3.51	3.48	3.48	0.81	0.85	0.87	0.89	

Note: The table shows the case where the operation frequency of a compressor is fixed.

EF-12RD1H+MX1-12RD1H								[SI_Unit]	
INDOOR AIRFLOW (CMH)	HEATING PERFORMANCE AT INDOOR DRY BULB TEMPERATURE								
	OUTDOOR DB(°C)	TC:TOTAL CAPACITY IN KILOWATTS (KW)				PI:TOTAL POWER IN KILOWATTS (KW)			
		Indoor Conditions (DB °C)				Indoor Conditions (DB °C)			
		16.0	20.0	22.0	24.0	16.0	20.0	22.0	24.0
600	-20.0	2.10	2.08	2.05	2.05	0.55	0.56	0.59	0.60
	-15.0	2.27	2.25	2.22	2.22	0.60	0.61	0.64	0.66
	-10.0	2.43	2.40	2.37	2.37	0.64	0.66	0.68	0.70
	-7.0	2.54	2.51	2.49	2.49	0.68	0.70	0.73	0.75
	-5.6	2.69	2.66	2.63	2.63	0.70	0.74	0.76	0.77
	-2.8	2.83	2.80	2.77	2.77	0.75	0.79	0.80	0.82
	0.0	2.95	2.89	2.89	2.86	0.79	0.83	0.85	0.87
	2.8	3.15	3.12	3.09	3.06	0.85	0.89	0.91	0.93
	5.6	3.47	3.44	3.41	3.38	0.91	0.95	0.97	0.99
	7.0	3.84	3.81	3.69	3.66	0.93	1.01	0.99	1.02
	11.1	4.10	4.04	4.01	3.98	1.00	1.05	1.07	1.10
	13.9	4.30	4.25	4.22	4.19	1.05	1.10	1.13	1.15
	16.7	4.54	4.48	4.45	4.39	1.10	1.16	1.18	1.21
18.0	4.62	4.57	4.54	4.51	1.13	1.18	1.21	1.23	

Note: The table shows the case where the operation frequency of a compressor is fixed.

EF-12RD1L+MX1-12RD1L								[SI_Unit]	
INDOOR AIRFLOW (CMH)	HEATING PERFORMANCE AT INDOOR DRY BULB TEMPERATURE								
	OUTDOOR DB(°C)	TC:TOTAL CAPACITY IN KILOWATTS (KW)				PI:TOTAL POWER IN KILOWATTS (KW)			
		Indoor Conditions (DB °C)				Indoor Conditions (DB °C)			
		16.0	20.0	22.0	24.0	16.0	20.0	22.0	24.0
590	-20.0	2.10	2.08	2.05	2.05	0.65	0.66	0.69	0.71
	-15.0	2.27	2.25	2.22	2.22	0.71	0.72	0.76	0.78
	-10.0	2.43	2.40	2.37	2.37	0.75	0.77	0.81	0.83
	-7.0	2.54	2.51	2.49	2.49	0.80	0.82	0.86	0.88
	-5.6	2.69	2.66	2.63	2.63	0.82	0.86	0.88	0.90
	-2.8	2.83	2.80	2.77	2.77	0.88	0.92	0.94	0.96
	0.0	2.95	2.89	2.89	2.86	0.93	0.97	1.00	1.02
	2.8	3.15	3.12	3.09	3.06	0.99	1.04	1.07	1.09
	5.6	3.47	3.44	3.41	3.38	1.06	1.11	1.13	1.16
	7.0	3.84	3.81	3.69	3.66	1.09	1.19	1.17	1.20
	11.1	4.10	4.04	4.01	3.98	1.18	1.24	1.26	1.29
	13.9	4.30	4.25	4.22	4.19	1.24	1.30	1.33	1.36
	16.7	4.54	4.48	4.45	4.39	1.30	1.36	1.39	1.42
18.0	4.62	4.57	4.54	4.51	1.32	1.39	1.42	1.45	

Note: The table shows the case where the operation frequency of a compressor is fixed.

EF-12RD1M+MX1-12RD1H								[SI_Unit]	
INDOOR AIRFLOW (CMH)	HEATING PERFORMANCE AT INDOOR DRY BULB TEMPERATURE								
	OUTDOOR DB(°C)	TC:TOTAL CAPACITY IN KILOWATTS (KW)				PI:TOTAL POWER IN KILOWATTS (KW)			
		Indoor Conditions (DB °C)				Indoor Conditions (DB °C)			
		16.0	20.0	22.0	24.0	16.0	20.0	22.0	24.0
600	-20.0	2.10	2.08	2.05	2.05	0.59	0.61	0.64	0.65
	-15.0	2.27	2.25	2.22	2.22	0.65	0.66	0.70	0.71
	-10.0	2.43	2.40	2.37	2.37	0.69	0.71	0.75	0.75
	-7.0	2.54	2.51	2.49	2.49	0.73	0.75	0.79	0.80
	-5.6	2.69	2.66	2.63	2.63	0.75	0.79	0.81	0.83
	-2.8	2.83	2.80	2.77	2.77	0.80	0.84	0.86	0.88
	0.0	2.95	2.89	2.89	2.86	0.85	0.89	0.91	0.93
	2.8	3.15	3.12	3.09	3.06	0.91	0.95	0.98	1.00
	5.6	3.47	3.44	3.41	3.38	0.97	1.01	1.04	1.06
	7.0	3.84	3.81	3.69	3.66	1.00	1.09	1.07	1.10
	11.1	4.10	4.04	4.01	3.98	1.08	1.13	1.16	1.18
	13.9	4.30	4.25	4.22	4.19	1.13	1.19	1.22	1.24
	16.7	4.54	4.48	4.45	4.39	1.19	1.24	1.27	1.30
18.0	4.62	4.57	4.54	4.51	1.21	1.27	1.30	1.33	

Note: The table shows the case where the operation frequency of a compressor is fixed.

EF-18RD1+MX3-18RD1-EF								[SI_Unit]	
INDOOR AIRFLOW (CMH)	HEATING PERFORMANCE AT INDOOR DRY BULB TEMPERATURE								
	OUTDOOR DB(°C)	TC:TOTAL CAPACITY IN KILOWATTS (KW)				PI:TOTAL POWER IN KILOWATTS (KW)			
		Indoor Conditions (DB °C)				Indoor Conditions (DB °C)			
		16.0	20.0	22.0	24.0	16.0	20.0	22.0	24.0
800	-25.0	2.75	2.71	2.69	2.69	0.69	0.70	0.73	0.76
	-20.0	2.99	2.94	2.92	2.92	0.76	0.77	0.81	0.83
	-15.0	3.24	3.19	3.16	3.16	0.83	0.85	0.88	0.91
	-10.0	3.45	3.40	3.38	3.38	0.88	0.90	0.94	0.97
	-7.0	3.62	3.56	3.54	3.54	0.94	0.96	1.00	1.03
	-5.6	3.82	3.77	3.74	3.74	0.96	1.01	1.04	1.06
	-2.8	4.03	3.97	3.94	3.91	1.03	1.08	1.10	1.13
	0.0	4.17	4.11	4.09	4.06	1.09	1.14	1.17	1.19
	2.8	4.49	4.43	4.40	4.35	1.16	1.22	1.25	1.27
	5.6	4.95	4.90	4.87	4.81	1.24	1.29	1.32	1.34
	7.0	5.46	5.40	5.23	5.20	1.28	1.39	1.37	1.40
	11.1	5.81	5.72	5.69	5.66	1.38	1.44	1.48	1.51
	13.9	6.13	6.04	5.98	5.95	1.44	1.51	1.55	1.58
16.7	6.42	6.33	6.30	6.24	1.51	1.58	1.62	1.66	
18.0	6.56	6.47	6.45	6.39	1.55	1.62	1.66	1.69	

Note: The table shows the case where the operation frequency of a compressor is fixed.

EF-24RD1+MX4-24RD1-EF								[SI_Unit]	
INDOOR AIRFLOW (CMH)	HEATING PERFORMANCE AT INDOOR DRY BULB TEMPERATURE								
	OUTDOOR DB(°C)	TC:TOTAL CAPACITY IN KILOWATTS (KW)				PI:TOTAL POWER IN KILOWATTS (KW)			
		Indoor Conditions (DB °C)				Indoor Conditions (DB °C)			
		16.0	20.0	22.0	24.0	16.0	20.0	22.0	24.0
1039	-25.0	3.72	3.68	3.66	3.64	1.06	1.09	1.14	1.16
	-20.0	4.04	4.00	3.97	3.95	1.16	1.20	1.25	1.28
	-15.0	4.37	4.32	4.30	4.28	1.27	1.31	1.37	1.40
	-10.0	4.67	4.62	4.59	4.57	1.36	1.40	1.46	1.49
	-7.0	4.89	4.84	4.81	4.78	1.44	1.48	1.55	1.58
	-5.6	5.19	5.13	5.10	5.07	1.49	1.56	1.60	1.63
	-2.8	5.48	5.39	5.36	5.33	1.58	1.66	1.70	1.74
	0.0	5.68	5.59	5.56	5.50	1.68	1.76	1.80	1.84
	2.8	6.08	6.00	5.97	5.94	1.79	1.88	1.92	1.97
	5.6	6.75	6.63	6.60	6.55	1.91	2.00	2.05	2.09
	7.0	7.46	7.33	7.10	7.07	1.97	2.15	2.12	2.17
	11.1	7.88	7.76	7.74	7.68	2.13	2.23	2.28	2.34
	13.9	8.32	8.20	8.14	8.08	2.24	2.34	2.40	2.45
16.7	8.72	8.60	8.55	8.49	2.34	2.45	2.51	2.57	
18.0	8.92	8.81	8.75	8.69	2.39	2.51	2.56	2.62	

Note: The table shows the case where the operation frequency of a compressor is fixed.

3. Capacity Correction Factor for Height Difference

Capacity(Btu/h)		7k/9k		Pipe Length (m)			
Indoor Upper than Outdoor				5	10	20	25
Height difference H (m)	Cooling	10			0.969	0.936	0.920
		5	0.995		0.979	0.946	0.929
		0	1.000		0.984	0.951	0.934
	Heating	10			0.989	0.967	0.956
		5	1.000		0.989	0.967	0.956
		0	1.000		0.989	0.967	0.956
Outdoor Upper than Indoor				5	10	20	30
Height difference H (m)	Cooling	0	1.000		0.984	0.951	0.934
		5	1.000		0.984	0.951	0.934
		10			0.984	0.951	0.934
	Heating	0	1.000		0.989	0.967	0.956
		5	0.992		0.981	0.959	0.948
		10			0.973	0.952	0.941

Capacity(Btu/h)		12k		Pipe Length (m)			
Indoor Upper than Outdoor				5	10	20	25
Height difference H (m)	Cooling	10			0.973	0.948	0.936
		5	0.995		0.983	0.958	0.945
		0	1.000		0.988	0.963	0.950
	Heating	10			0.993	0.978	0.970
		5	1.000		0.993	0.978	0.970
		0	1.000		0.993	0.978	0.970
Outdoor Upper than Indoor				5	10	20	30
Height difference H (m)	Cooling	0	1.000		0.988	0.963	0.950
		5	1.000		0.988	0.963	0.950
		10			0.988	0.963	0.950
	Heating	0	1.000		0.993	0.978	0.970
		5	0.992		0.985	0.970	0.962
		10			0.977	0.962	0.955

Capacity(Btu/h)	18k	Pipe Length (m)				
Indoor Upper than Outdoor		5	10	20	30	
Height difference H (m)	Cooling	20			0.928	0.912
		10		0.969	0.937	0.921
		5	0.995	0.979	0.946	0.930
		0	1.000	0.984	0.951	0.935
	Heating	20			0.982	0.976
		10		0.994	0.982	0.976
		5	1.000	0.994	0.982	0.976
		0	1.000	0.994	0.982	0.976
Outdoor Upper than Indoor		5	10	20	30	
Height difference H (m)	Cooling	0	1.000	0.984	0.951	0.935
		5	1.000	0.984	0.951	0.935
		10		0.984	0.951	0.935
		20			0.951	0.935
	Heating	0	1.000	0.994	0.982	0.976
		5	0.992	0.986	0.974	0.968
		10		0.978	0.966	0.960
		20			0.959	0.953

Capacity(Btu/h)	24k		Pipe Length (m)					
Indoor Upper than Outdoor			5	10	20	30	40	50
Height difference H (m)	Cooling	25				0.914	0.894	0.874
		20			0.944	0.924	0.903	0.883
		10		0.975	0.954	0.933	0.912	0.891
		5	0.995	0.984	0.963	0.942	0.921	0.900
		0	1.000	0.989	0.968	0.947	0.926	0.905
	Heating	25				0.983	0.977	0.97
		20			0.990	0.983	0.977	0.97
		10		0.997	0.990	0.983	0.977	0.97
		5	1.000	0.997	0.990	0.983	0.977	0.97
		0	1.000	0.997	0.990	0.983	0.977	0.97
Outdoor Upper than Indoor			5	10	20	30	40	50
Height difference H (m)	Cooling	0	1.000	0.989	0.968	0.947	0.926	0.905
		5	1.000	0.989	0.968	0.947	0.926	0.905
		10		0.989	0.968	0.947	0.926	0.905
		20			0.968	0.947	0.926	0.905
		25				0.947	0.926	0.905
	Heating	0	1.000	0.997	0.990	0.983	0.977	0.970
		5	0.992	0.989	0.982	0.975	0.969	0.962
		10		0.981	0.974	0.968	0.961	0.955
		20			0.966	0.960	0.953	0.947
		25				0.952	0.946	0.939

4. Dimensional Drawings & Centre of gravity

4.1 Dimensional Drawings

4.1.1 Indoor Unit

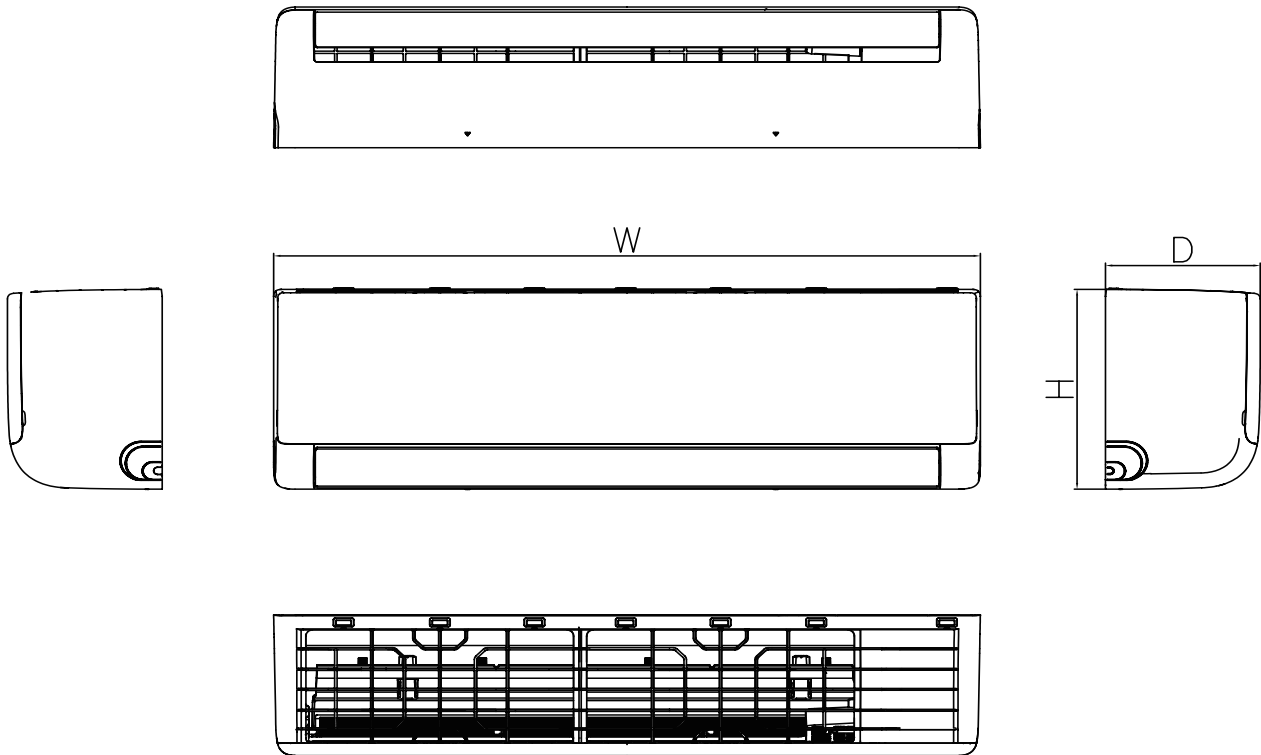

Capacity (Btu/h)	Unit	W	D	H
7k/9k	mm	723	199	286
12k	mm	813	201	289
18k	mm	975	218	308
24k	mm	1055	231	330

4.1.2 Outdoor Unit
7k

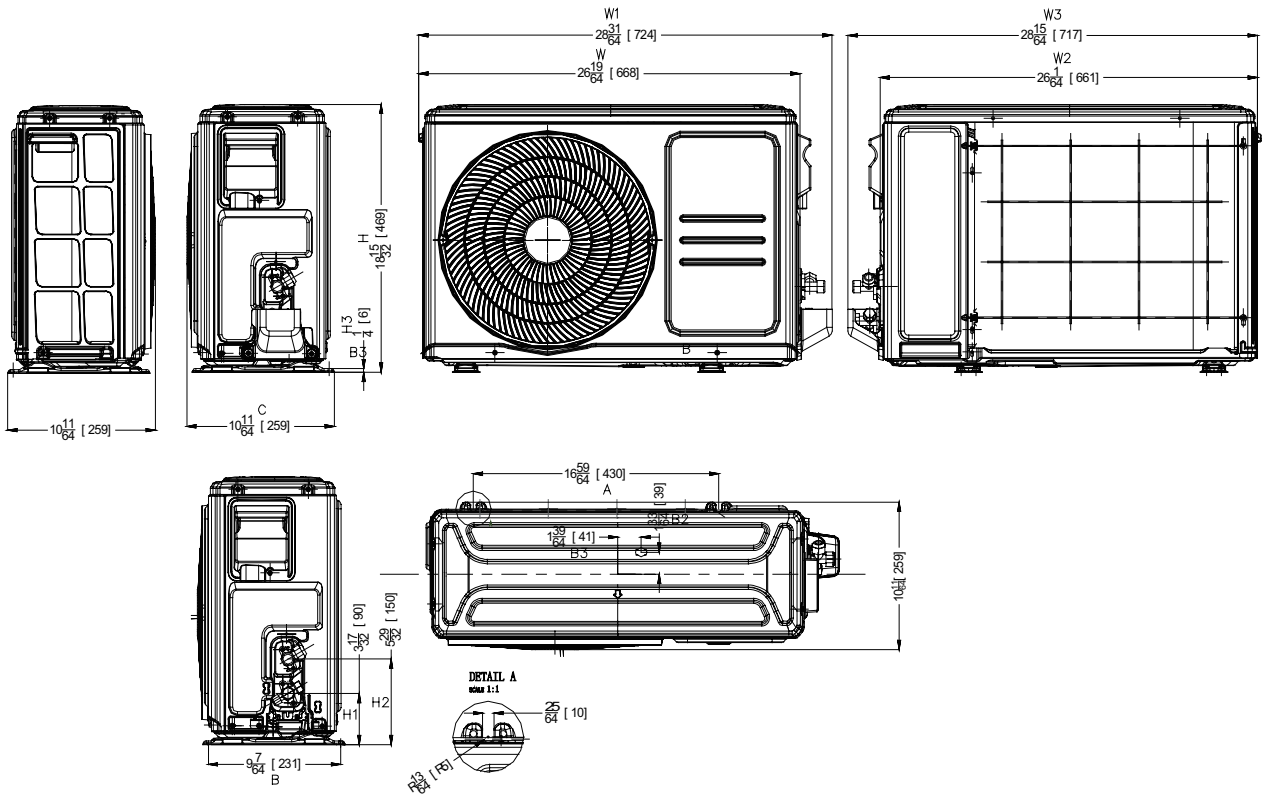

9k/12k

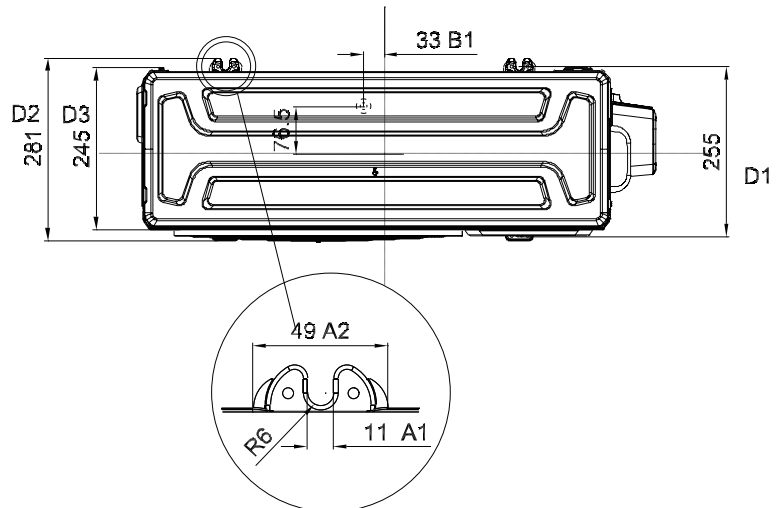
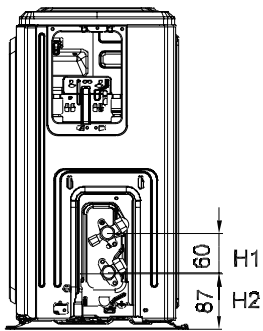
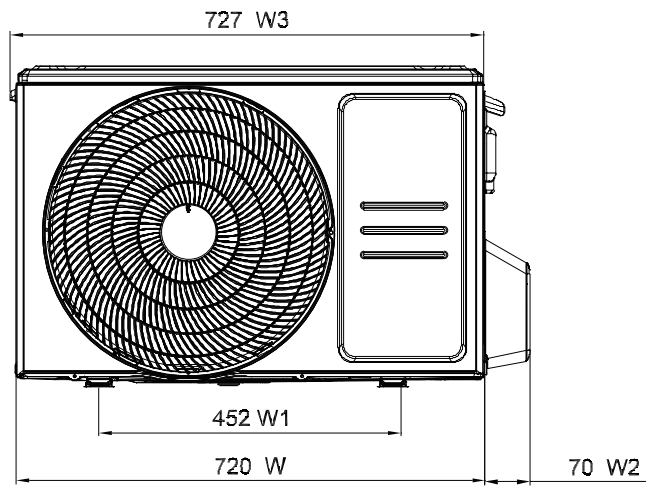
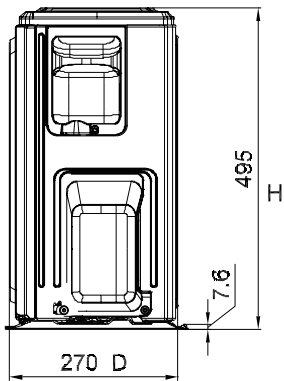

18k

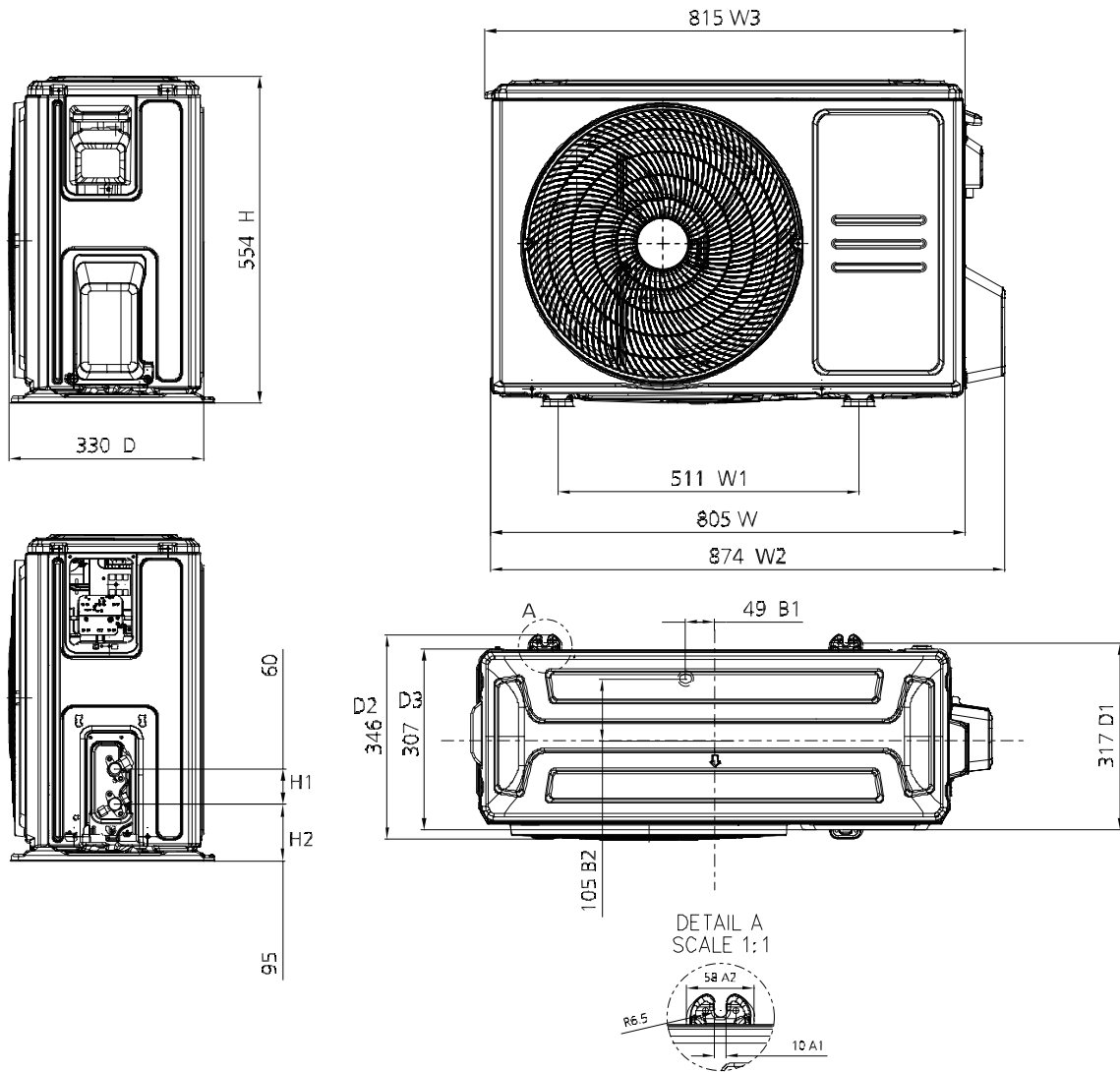

24k

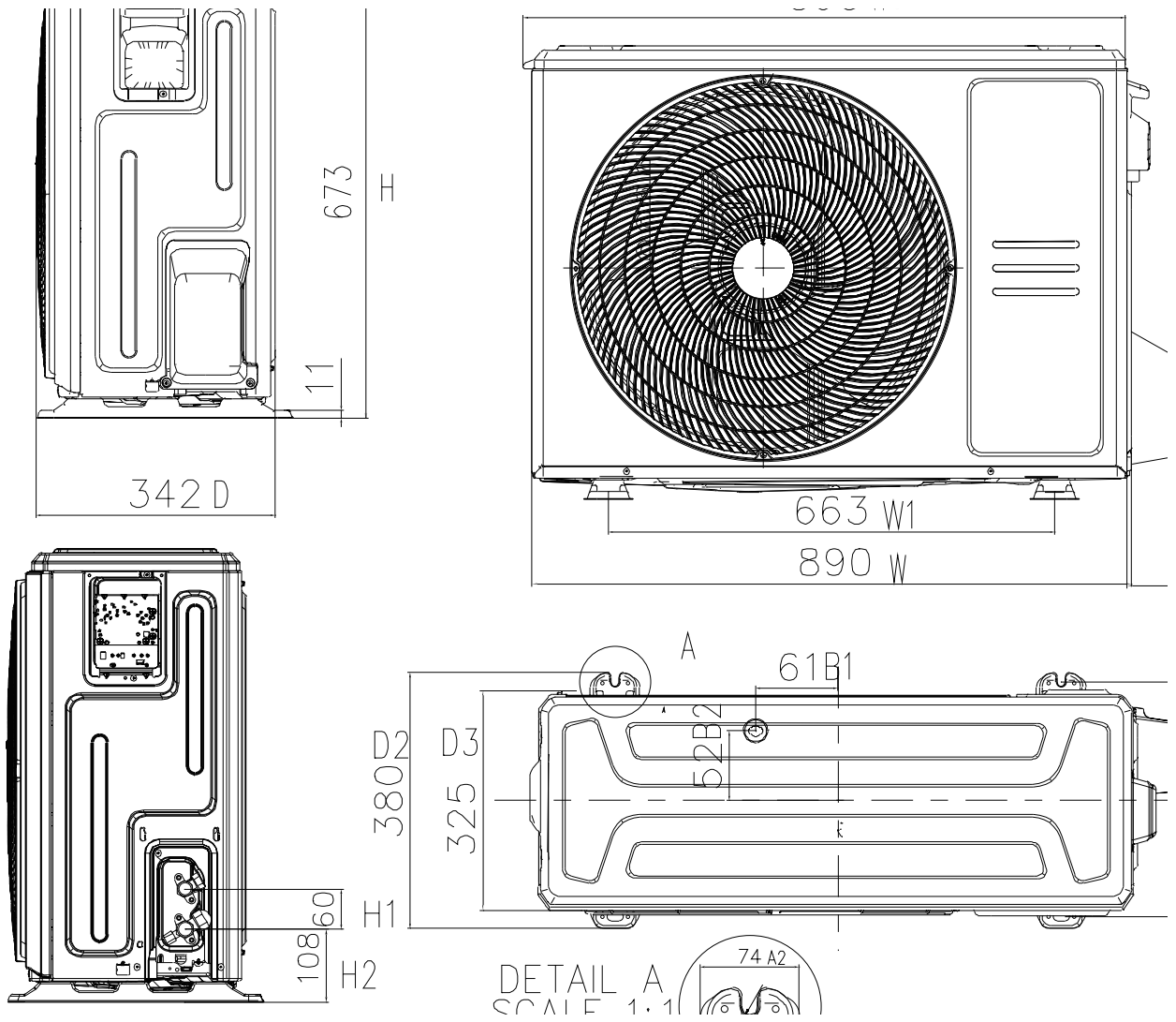

4.2 Centre of gravity

7k

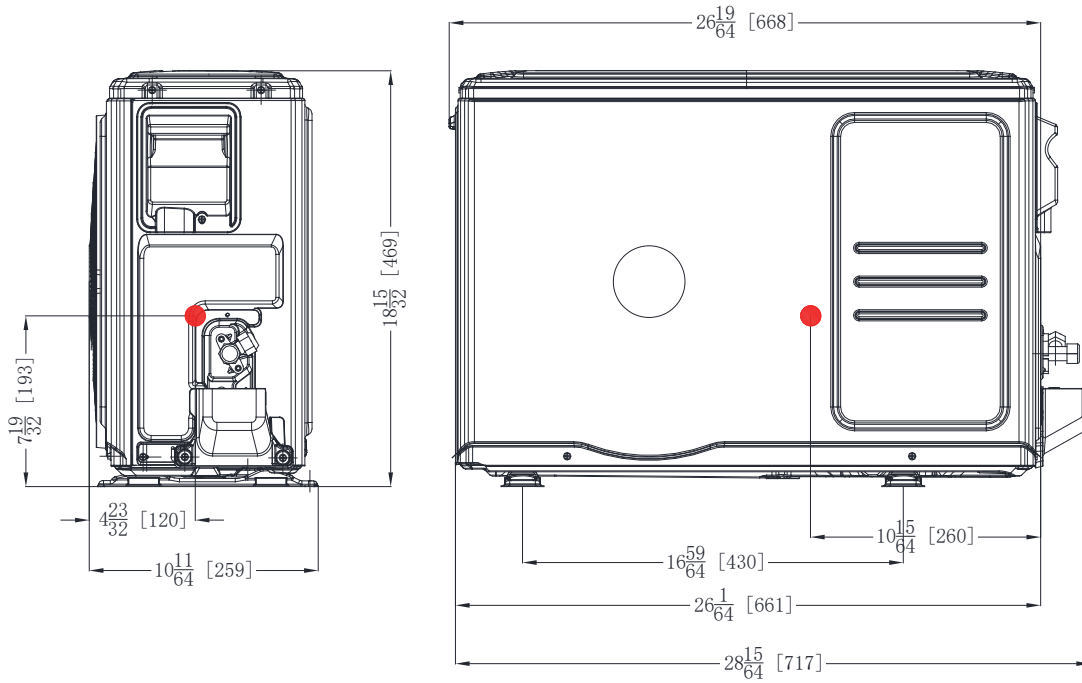

9k/12k

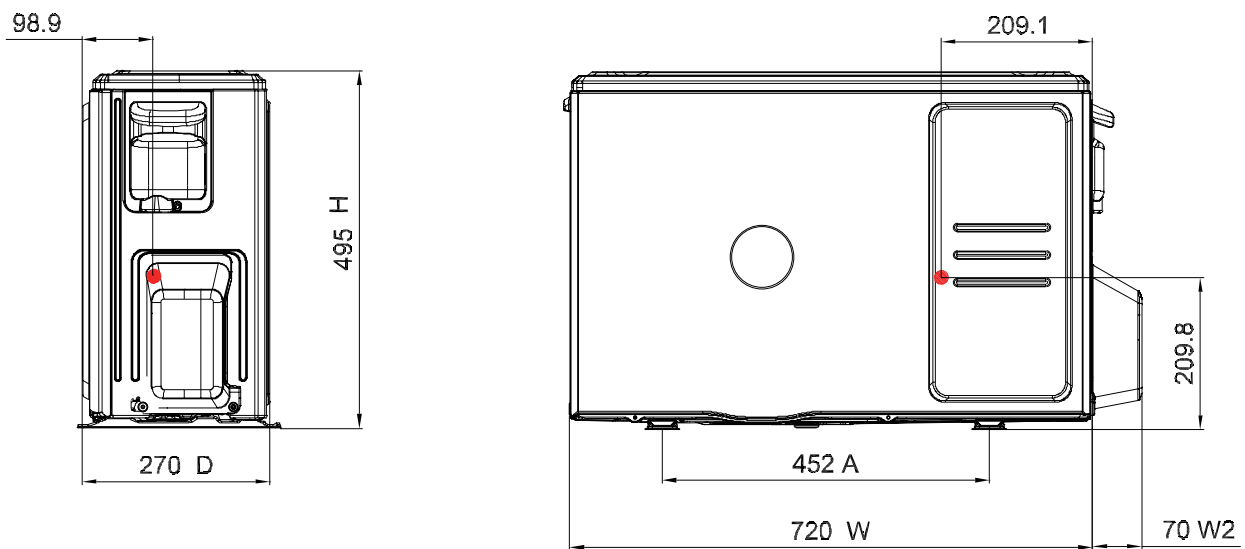

18k

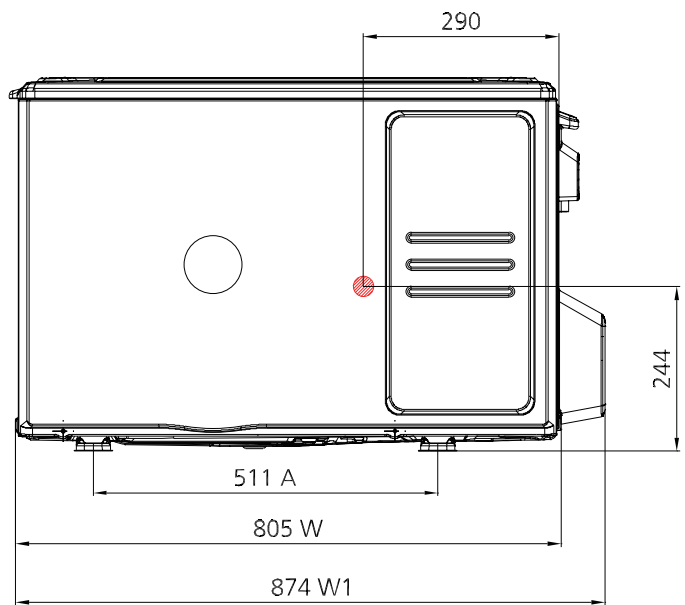
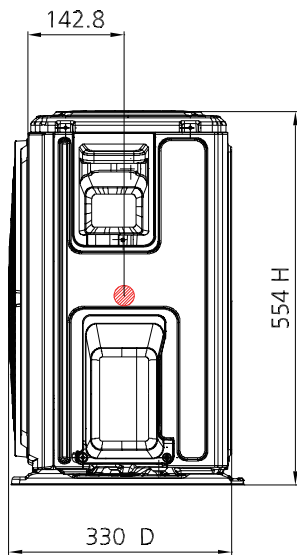

24k

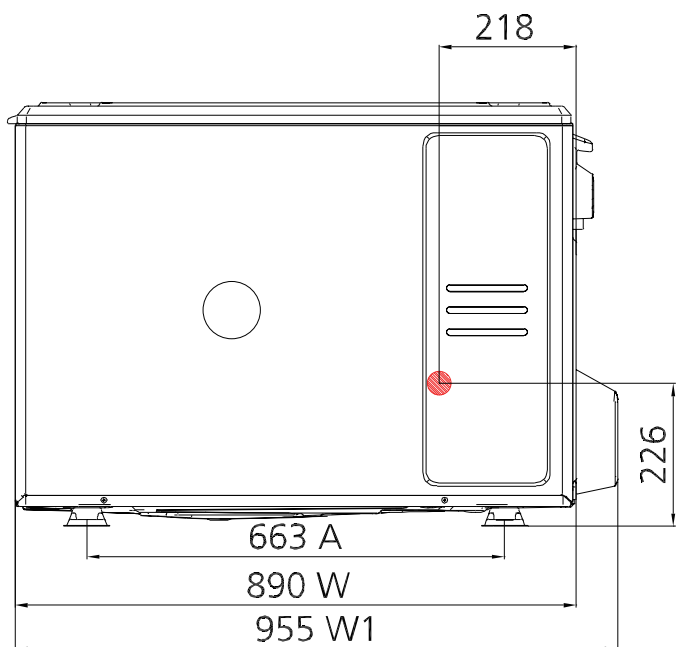
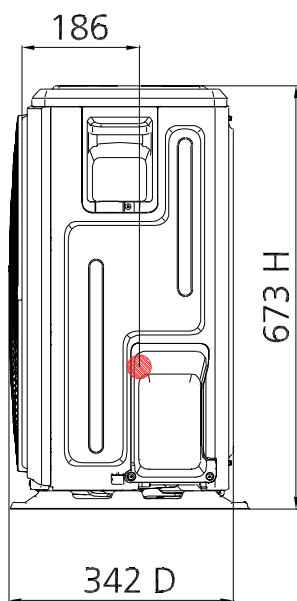

5. Electrical Wiring Diagrams

5.1 Indoor unit

Abbreviation	Paraphrase
Y/G	Yellow-Green Conductor
ION	Positive and Negative Ion Generator
CAP	Capacitor
PLASMA	Electronic Dust Collector
L	LIVE
N	NEUTRAL

7k~24k

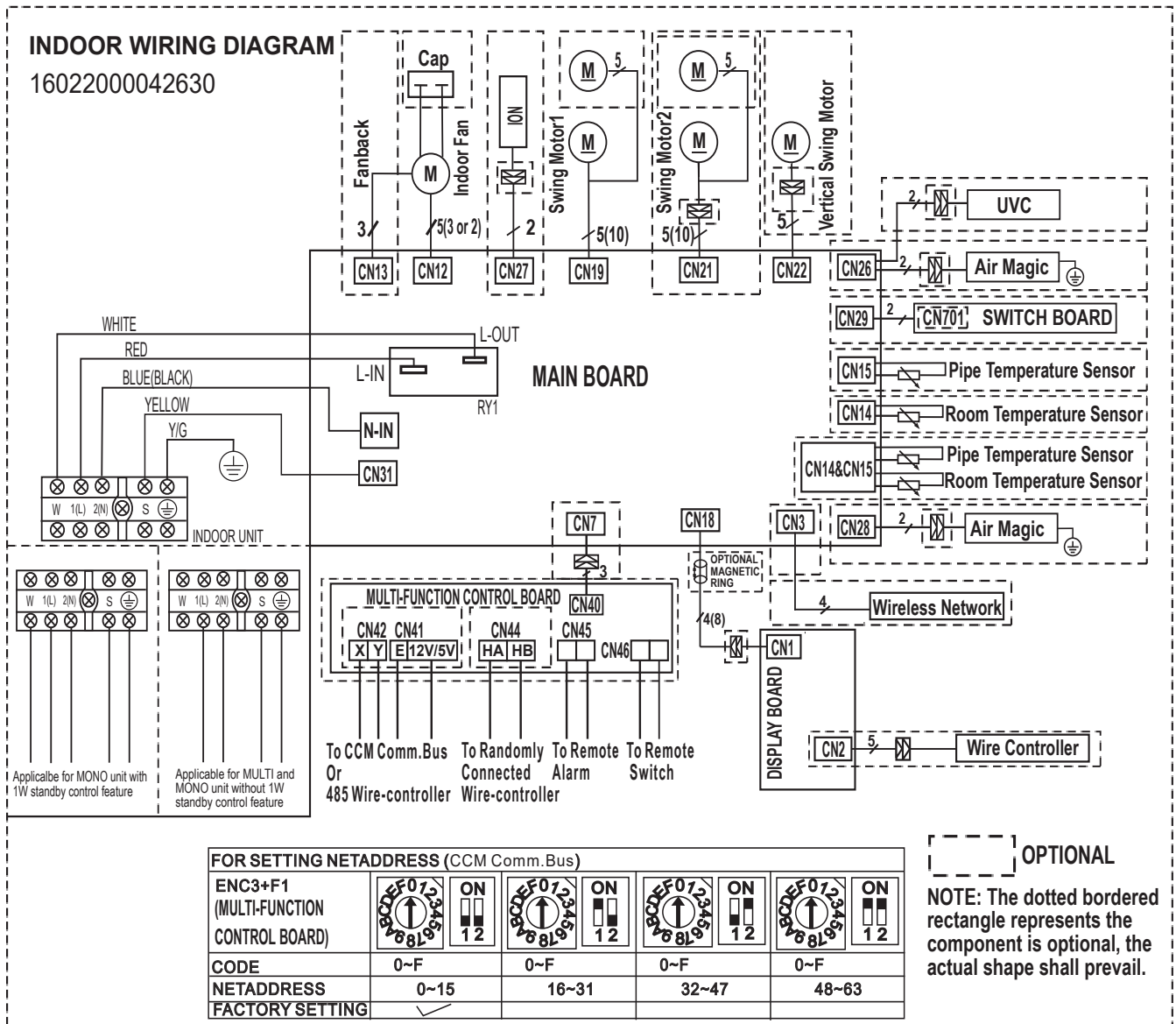

5.2 Outdoor Unit

Abbreviation	Paraphrase
4-WAY	Gas Valve Assembly/4-WAY VALVE
AC-FAN	Alternating Current FAN
DC-FAN	Direct Current FAN
COMP	Compressor

7k~24k

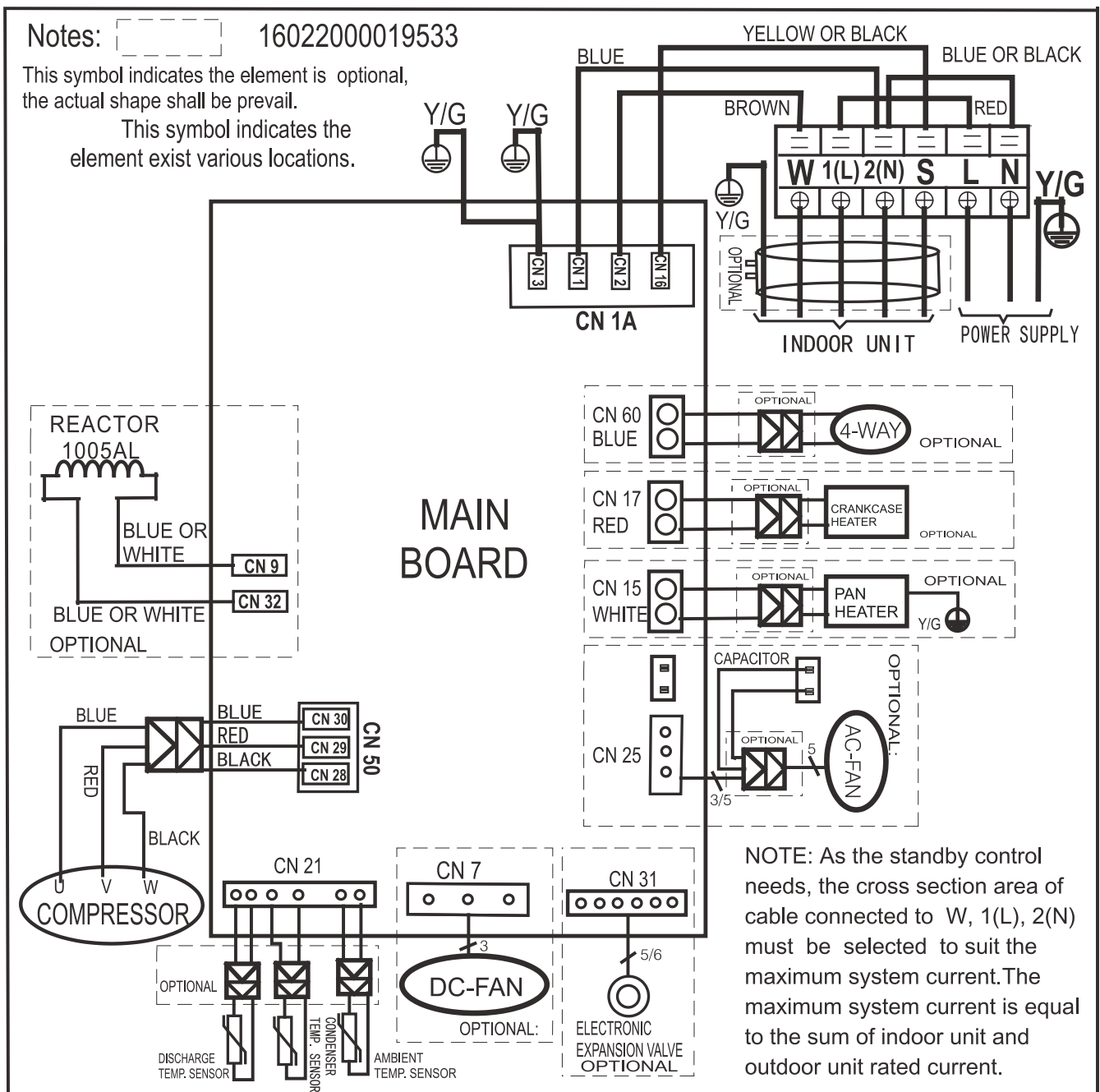

6. Refrigerant Cycle Diagrams

7k/9k/12k

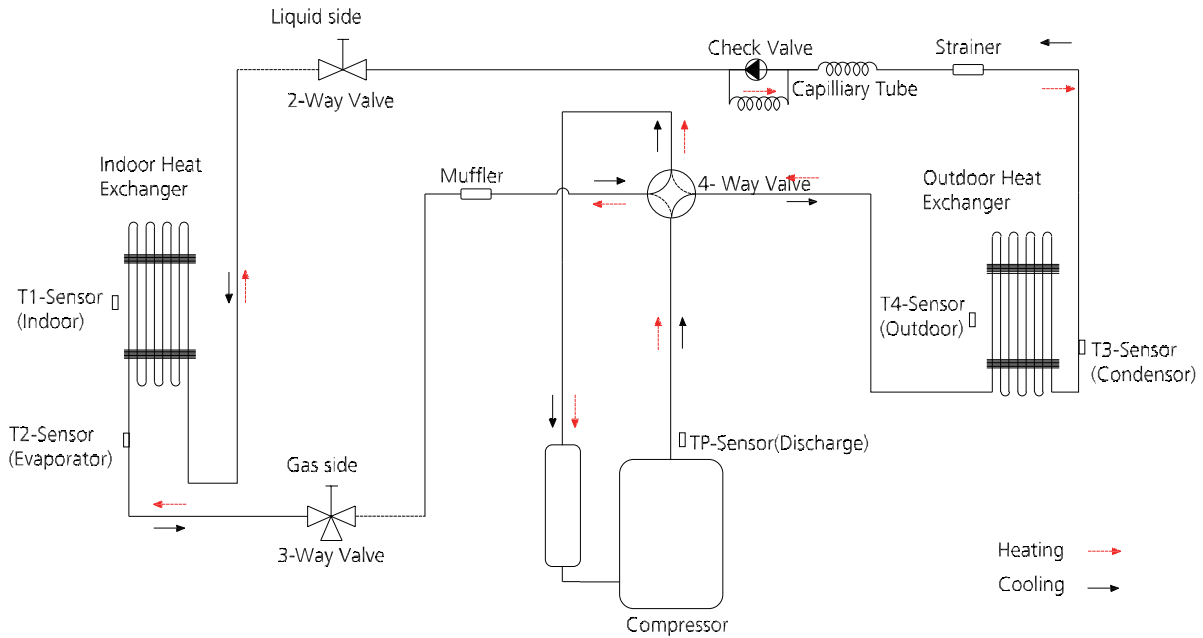

18k

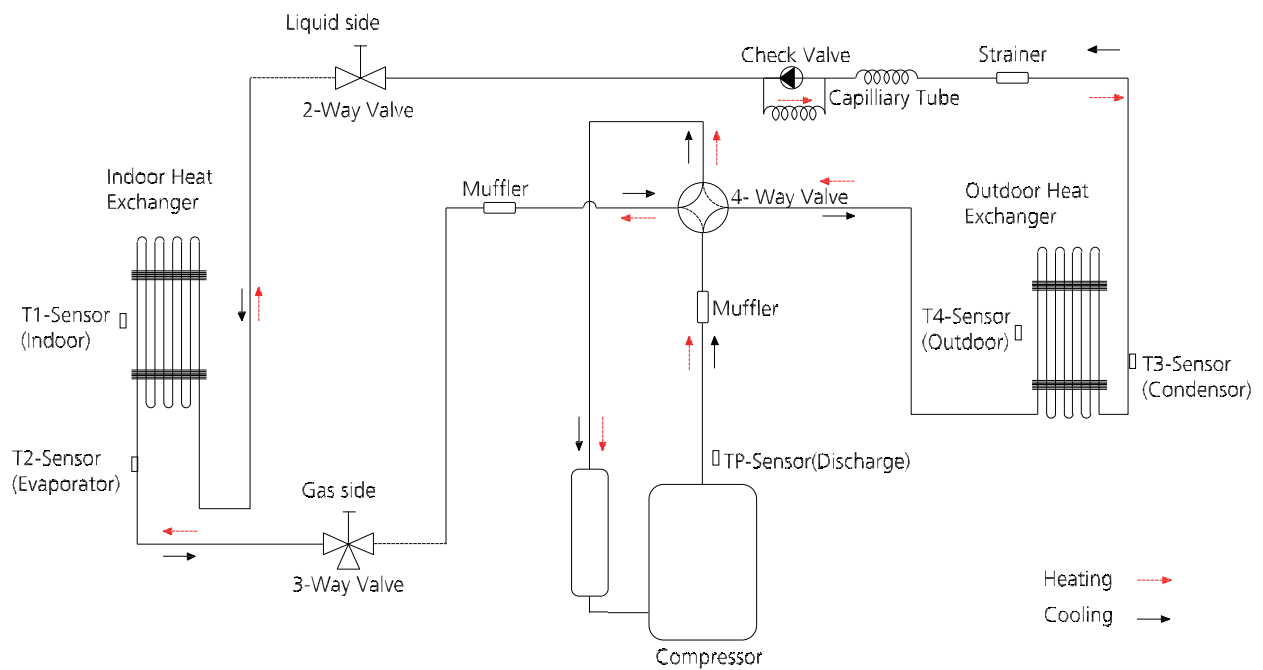

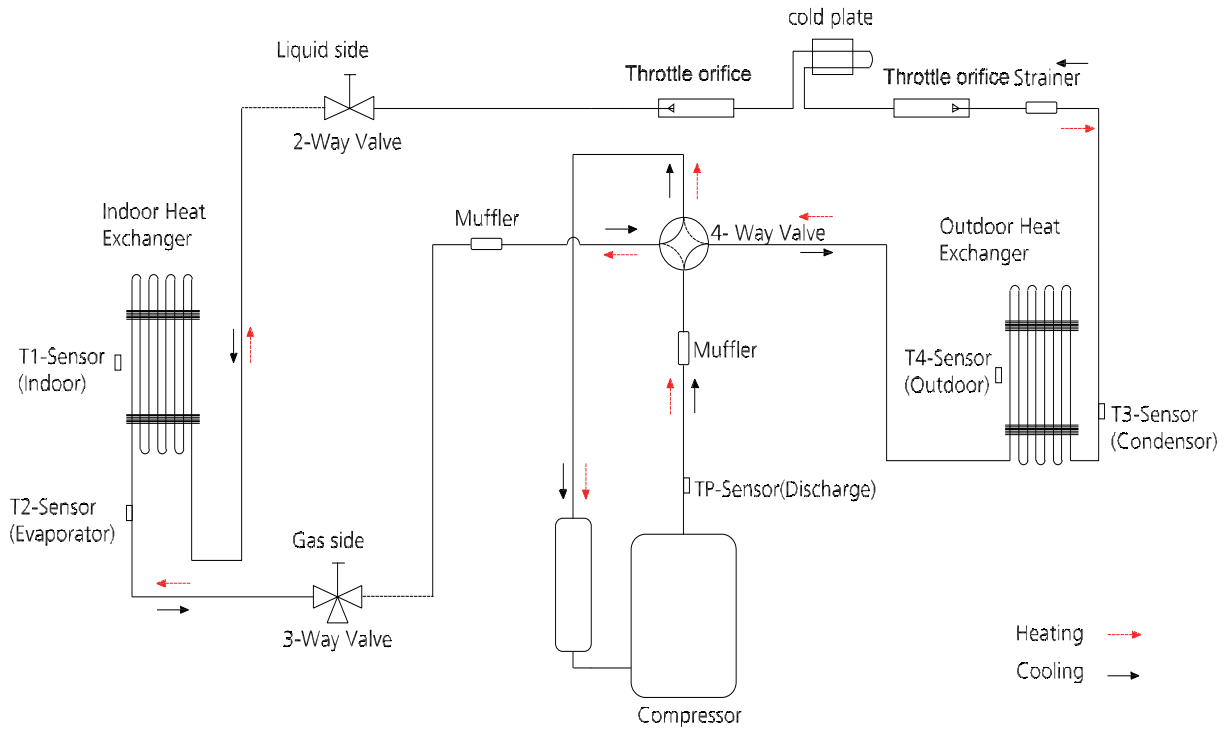

7. Noise Criterion Curves

7.1 Indoor Unit

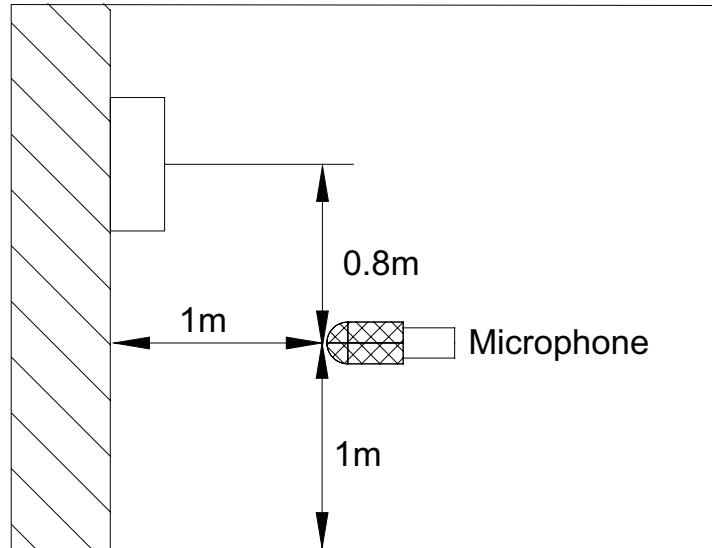

Notes:

- Sound measured at 1.0m away from the center of the unit.
- Data is valid at nominal operation condition
- Reference acoustic pressure $OdB = 20\mu Pa$
- Sound level will vary depending on a range of factors such as the construction -(acoustic absorption coefficient) of particular room in which the equipment is installed.
- The operating conditions are assumed to be standard.

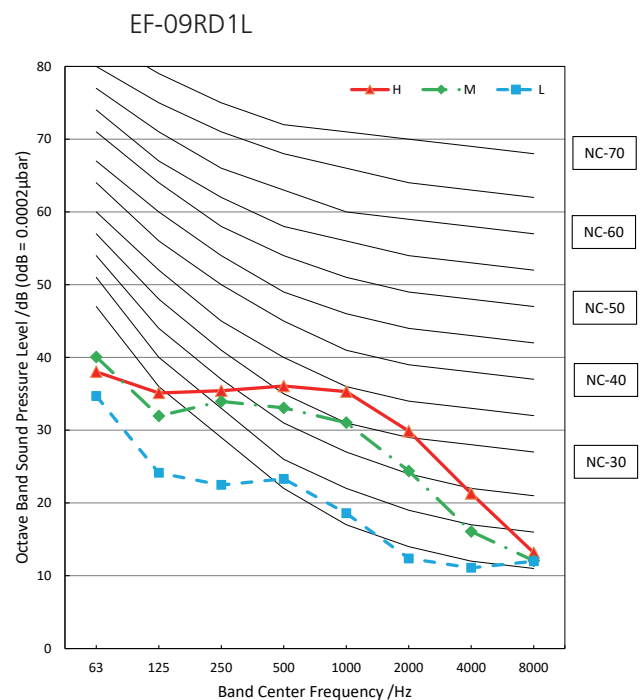
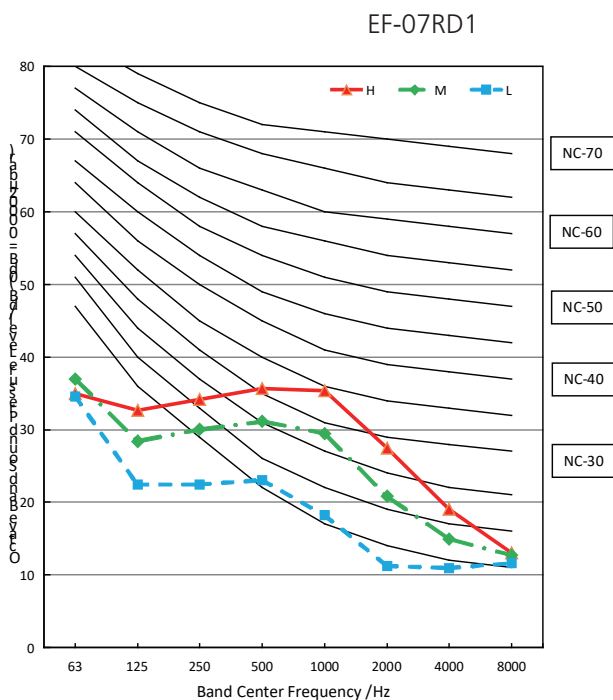

EF-09RD1H

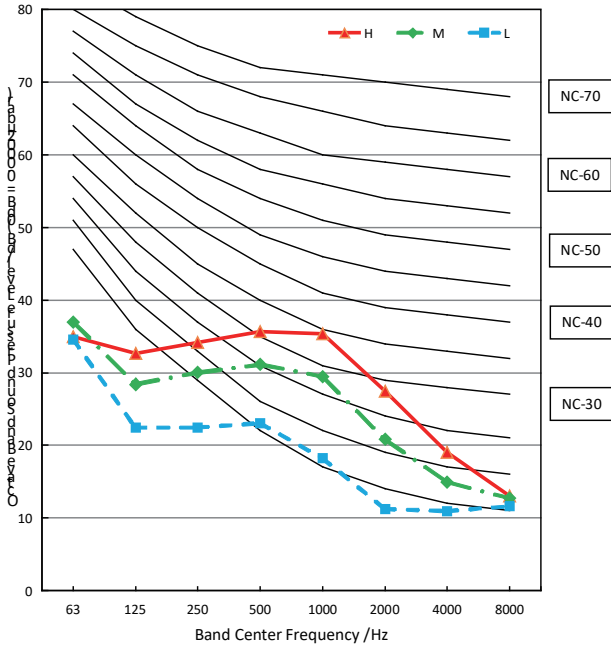

EF-12RD1L[N]

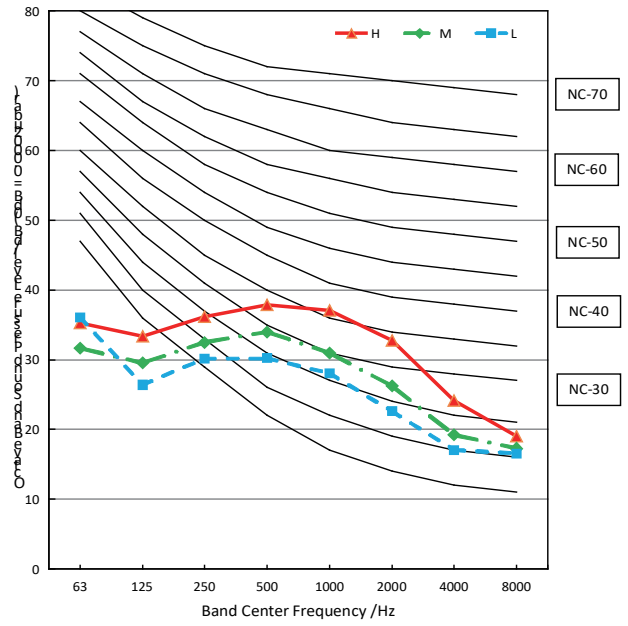

EF-12RD1H

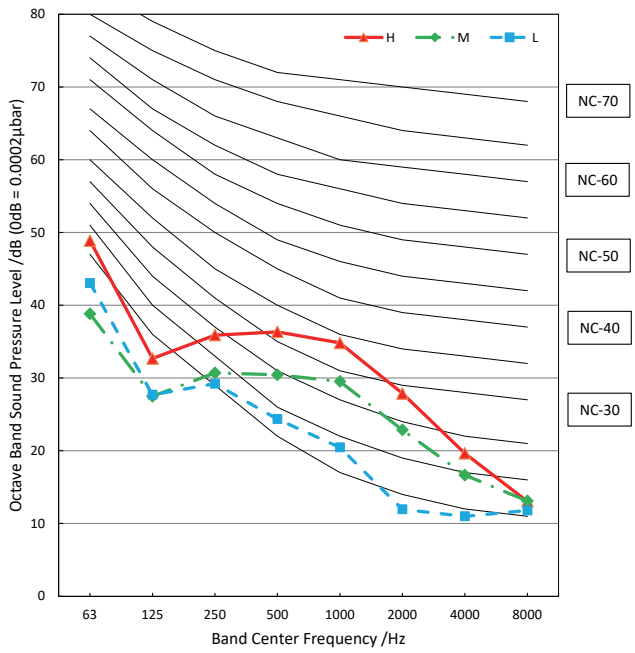

EF-12RD1L

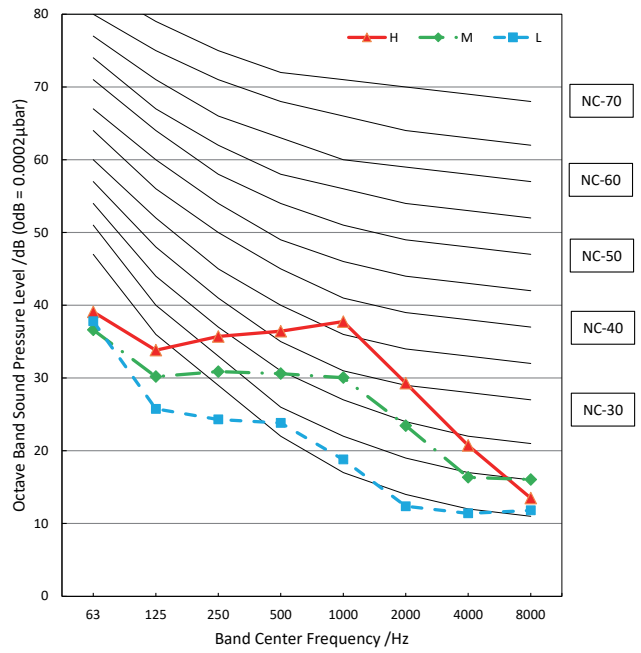

EF-18RD1

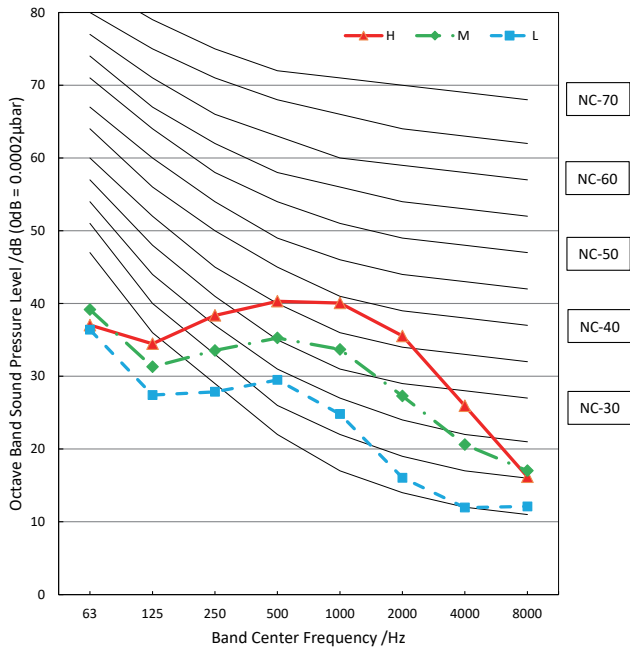

EF-24RD1

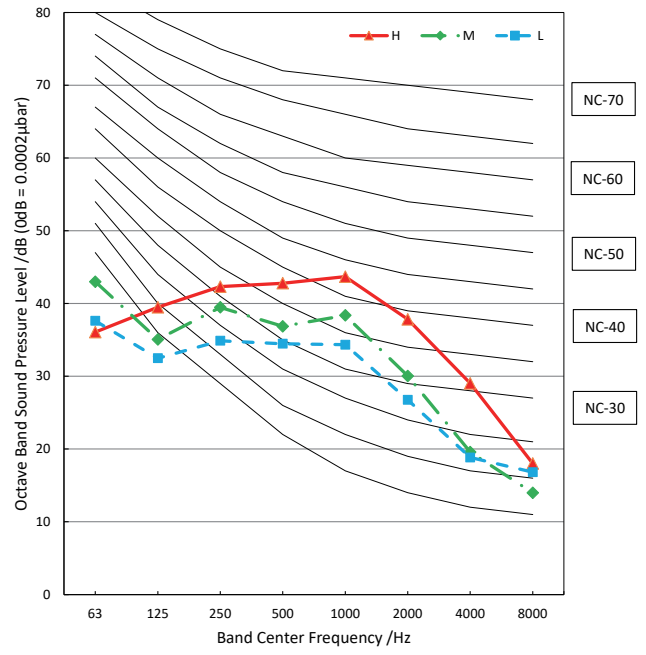

7.2 Outdoor Unit

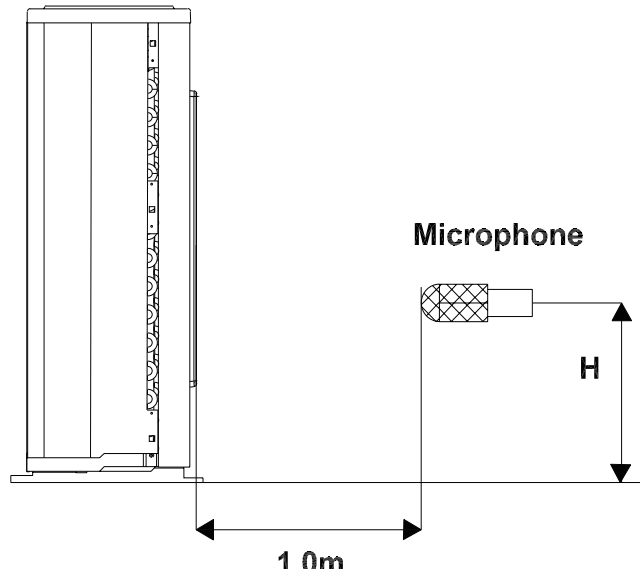

Note: $H = 0.5 \times$ height of outdoor unit

Notes:

- Sound measured at 1.0m away from the center of the unit.
- Data is valid at free field condition
- Data is valid at nominal operation condition
- Reference acoustic pressure $OdB=20\mu Pa$
- Sound level will vary depending on arrange off actors such as the construction (acoustic absorption coefficient) of particular room in which the equipment is installed.
- The operating conditions are assumed to be standard.

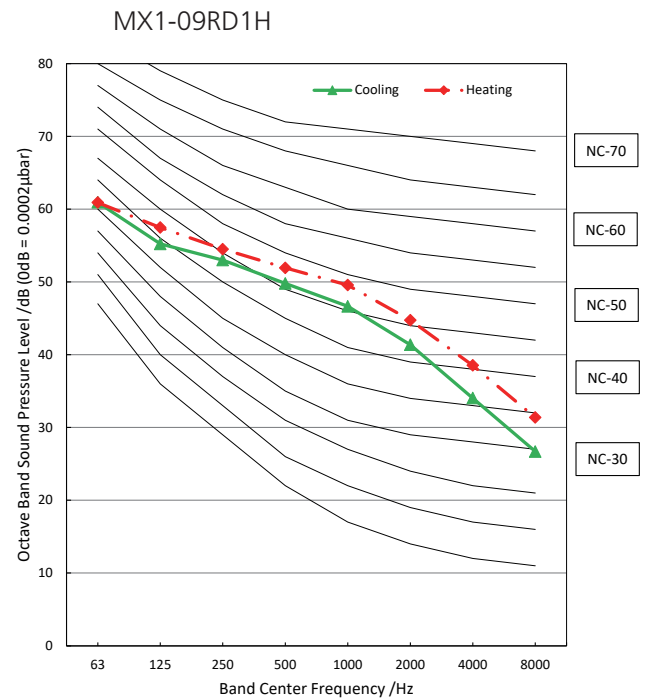
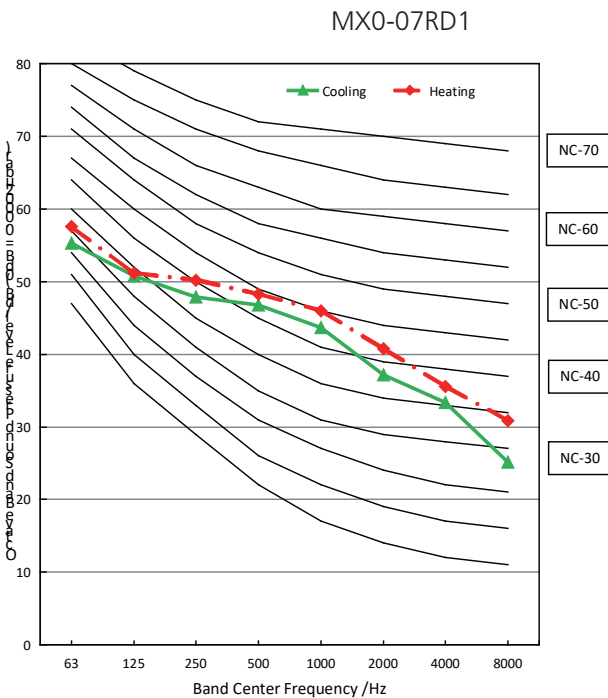

MX1-12RD1H

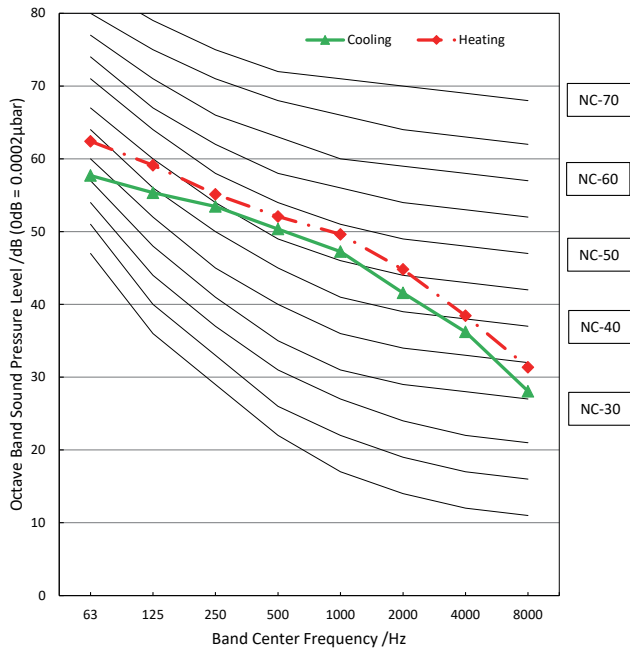

MX1-12RD1L

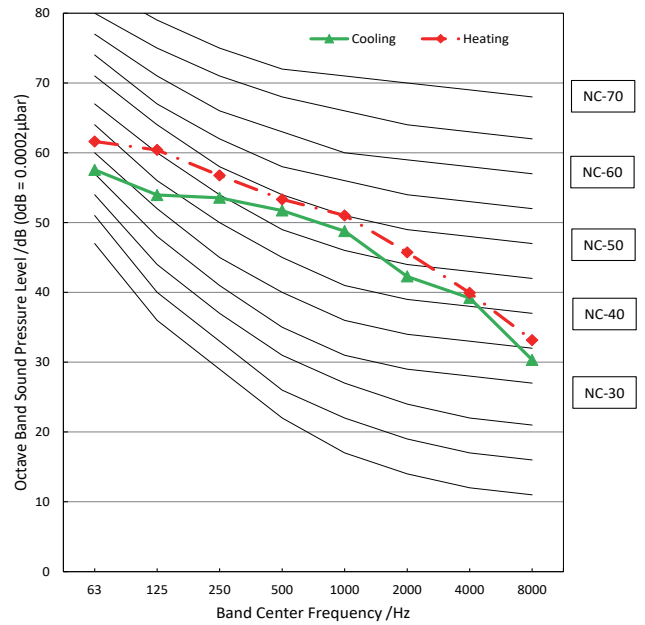

MX3-18RD1-EF

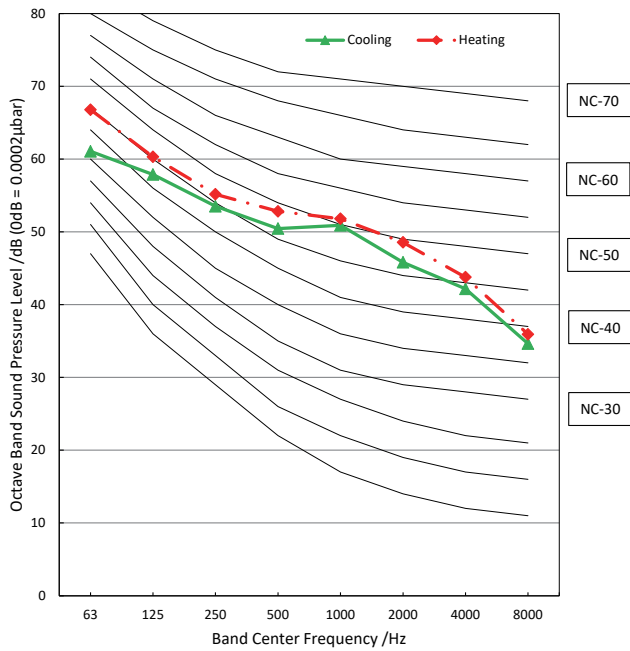

MX4-24RD1-EF

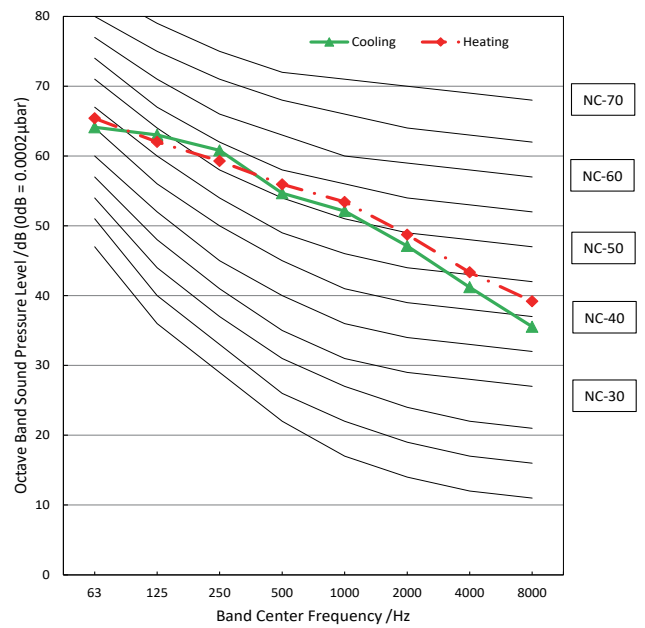

8. Air Velocity and Temperature Distributions

7k/9k

Cooling(ID: 27°C/80.6°F, OD: 35°C/95°F)

Discharge Angle 20°

Airflow velocity distributions

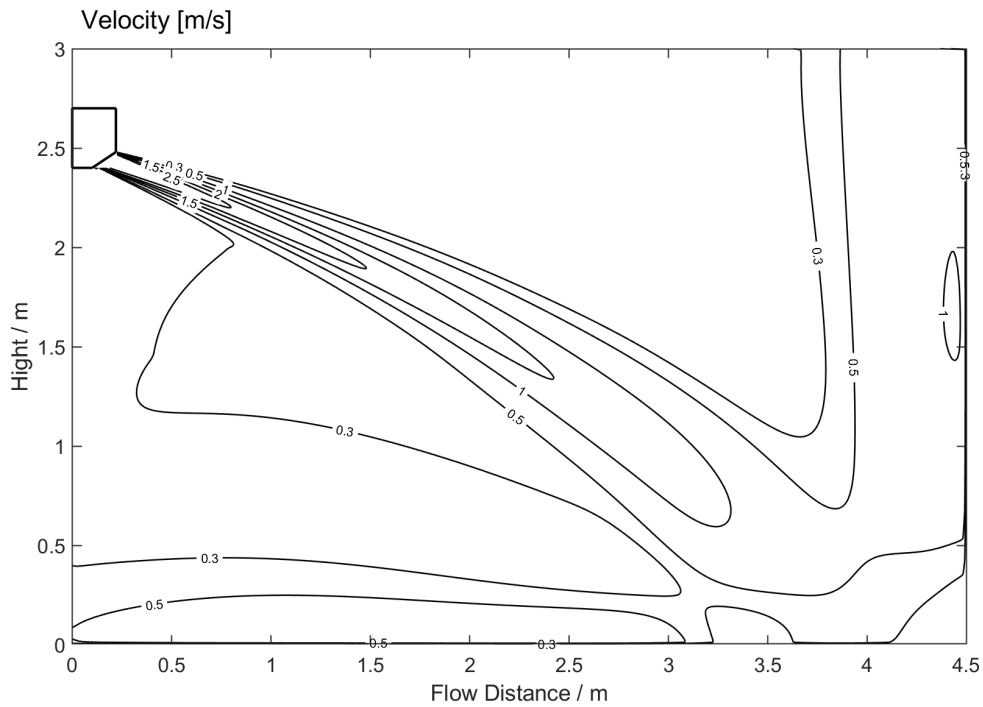

Temperature distributions

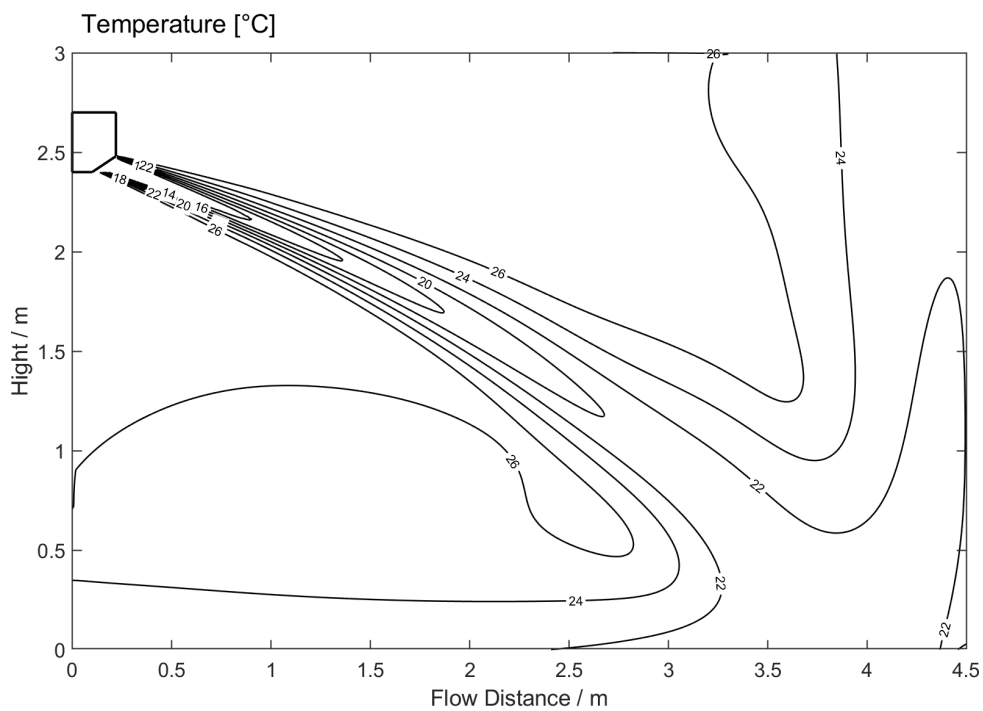

Heating(ID: 20°C/68°F, OD: 7°C/44.6°F)

Discharge Angle 65°

Airflow velocity distributions

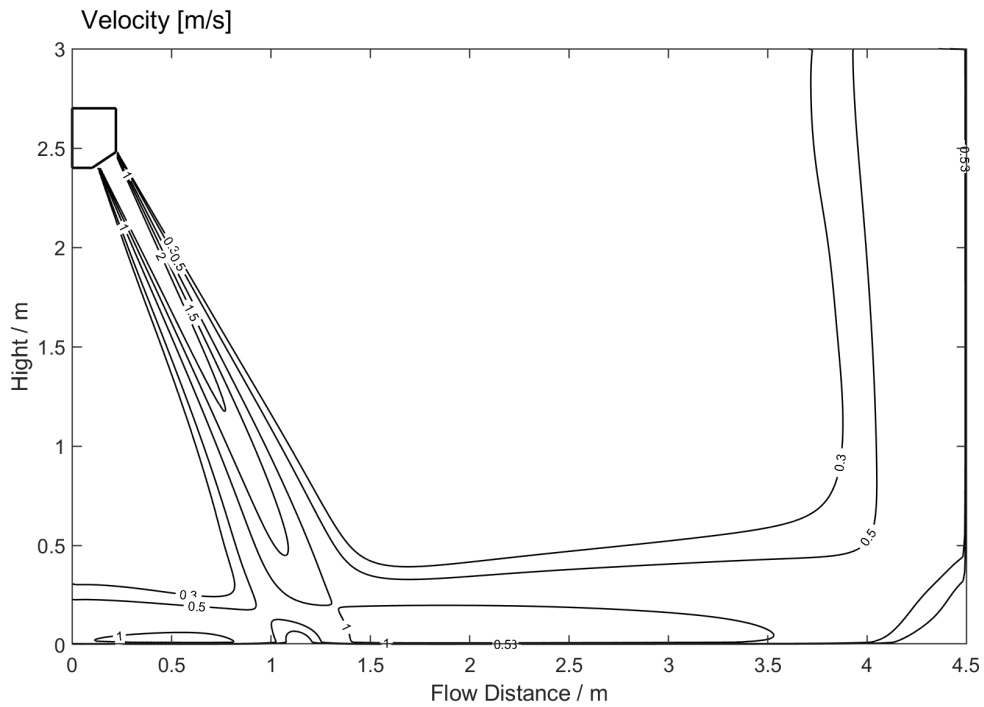

Temperature distributions

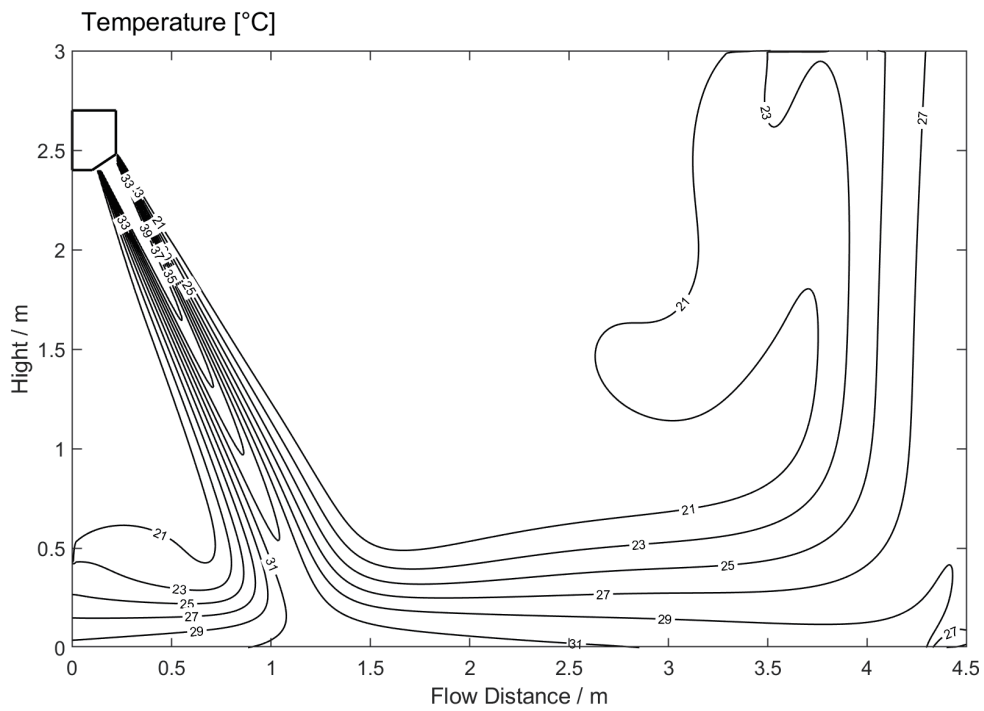

12k

Cooling(ID: 27°C/80.6°F, OD: 35°C/95°F)

Discharge Angle 20°

Airflow velocity distributions

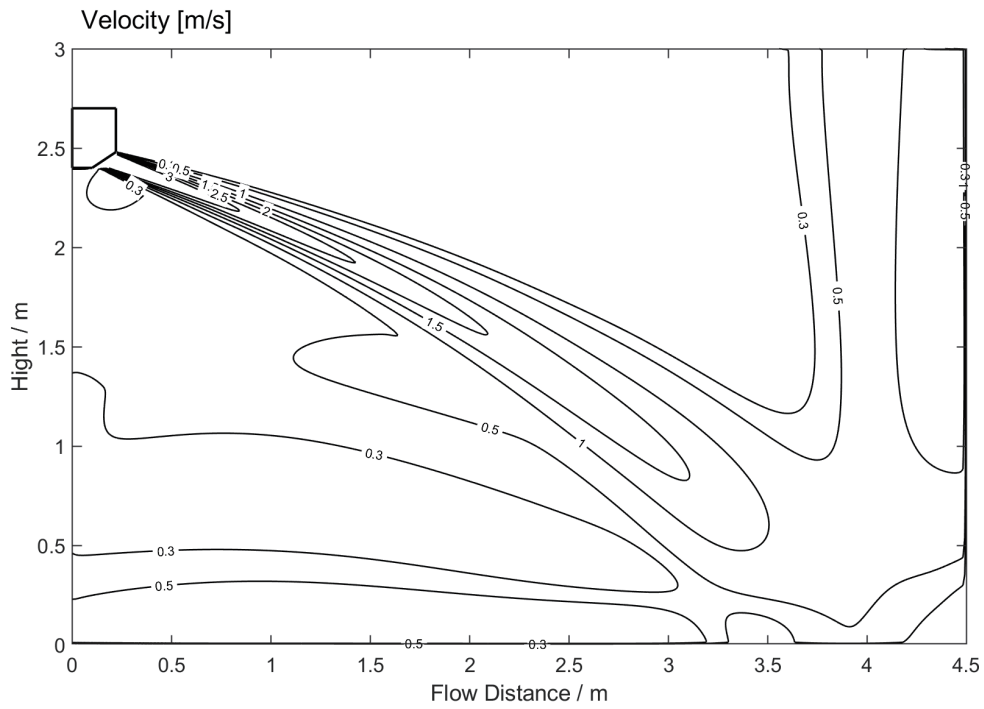

Temperature distributions

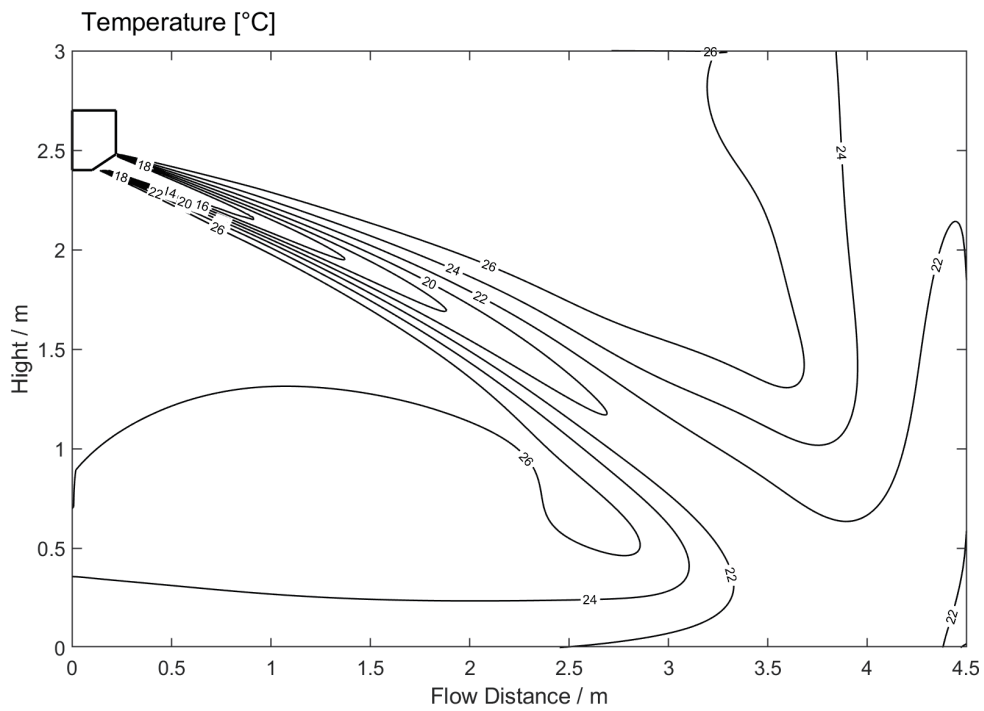

Heating(ID: 20°C/68°F, OD: 7°C/44.6°F)

Discharge Angle 65°

Airflow velocity distributions

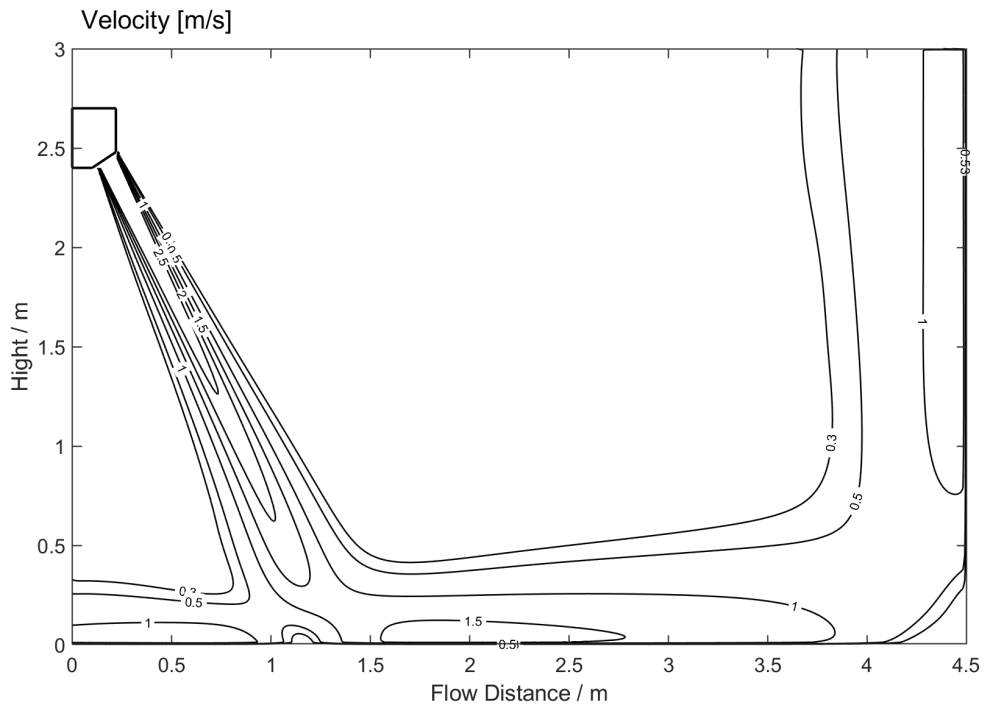

Temperature distributions

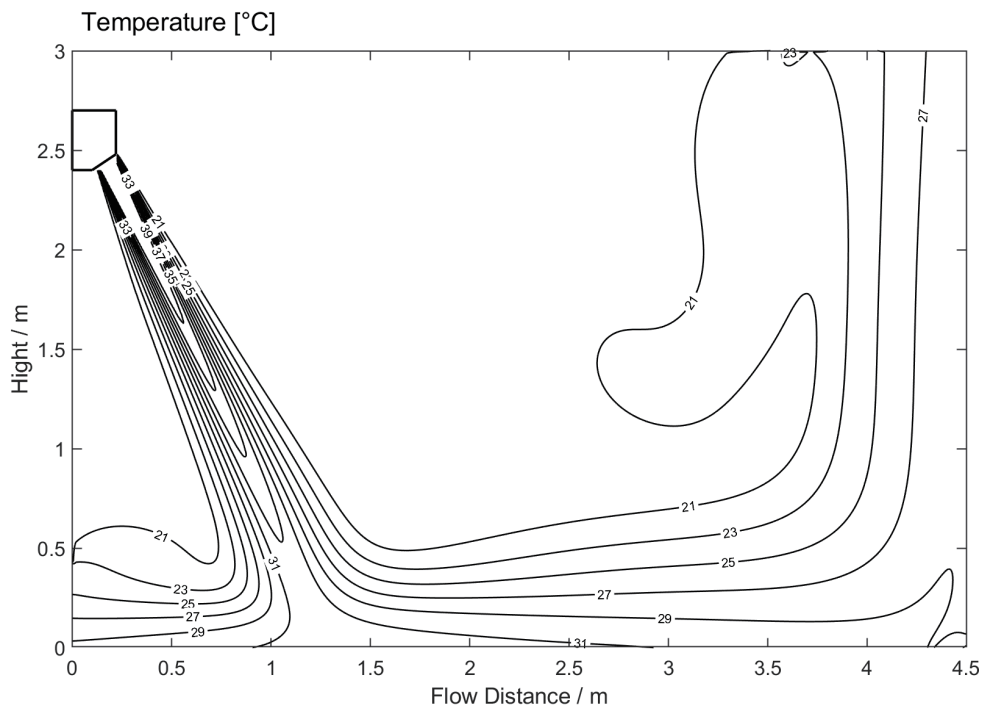

18k

Cooling(ID: 27°C/80.6°F, OD: 35°C/95°F)

Discharge Angle 18°

Airflow velocity distributions

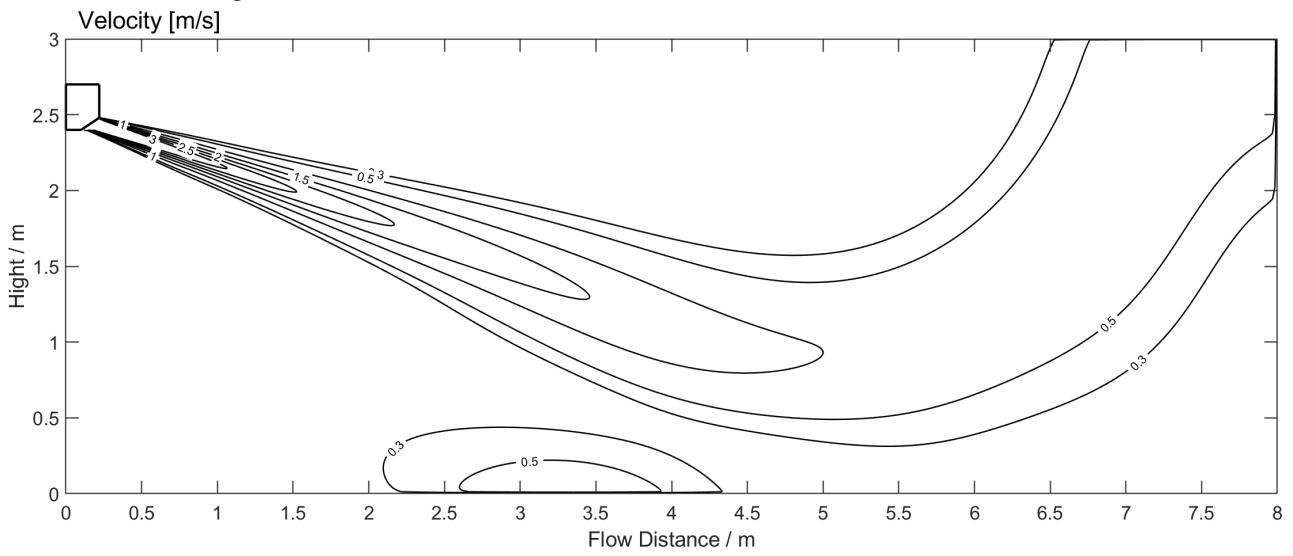

Temperature distributions

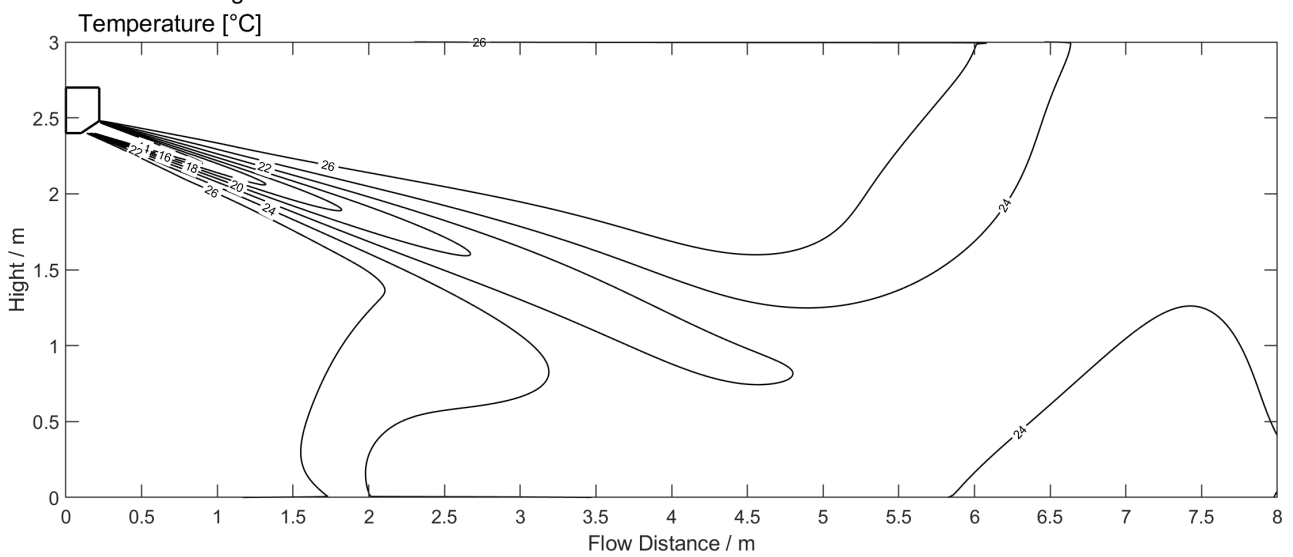

Heating(ID: 20°C/68°F, OD: 7°C/44.6°F)

Discharge Angle 62°

Airflow velocity distributions

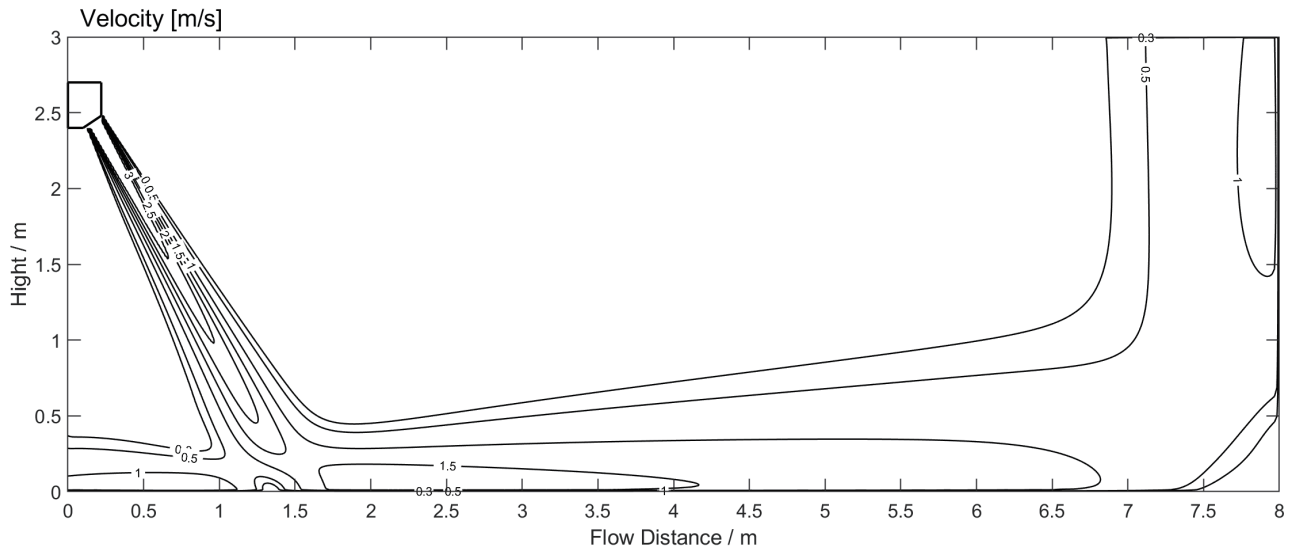

Temperature distributions

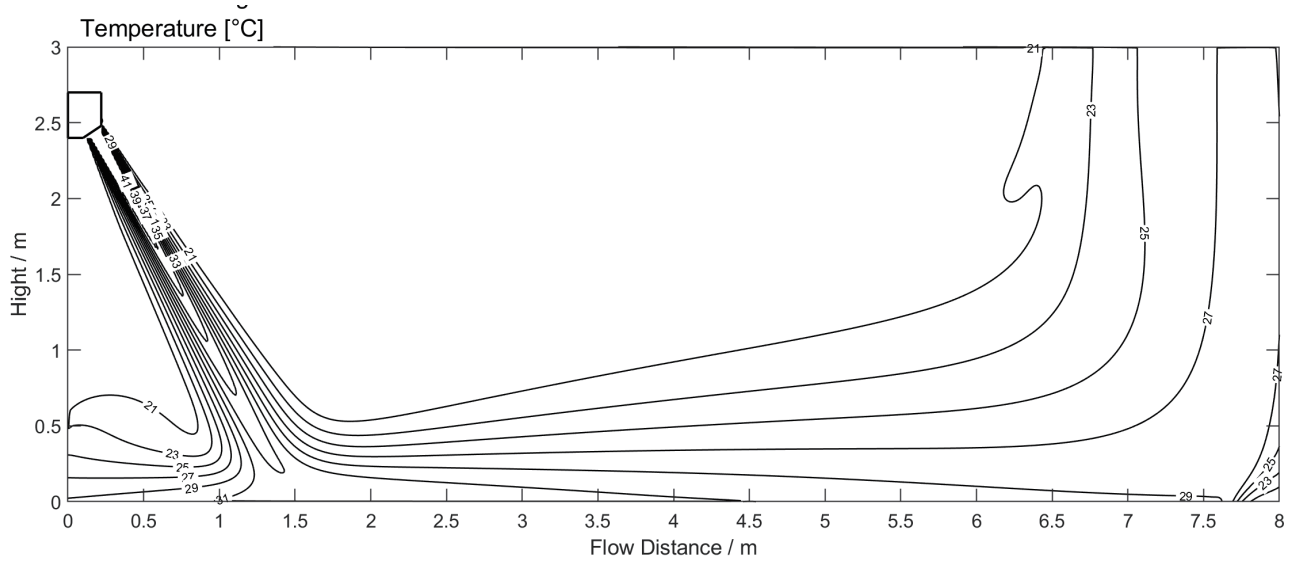

24k

Cooling(ID: 27°C/80.6°F, OD: 35°C/95°F)

Discharge Angle 20°

Airflow velocity distributions

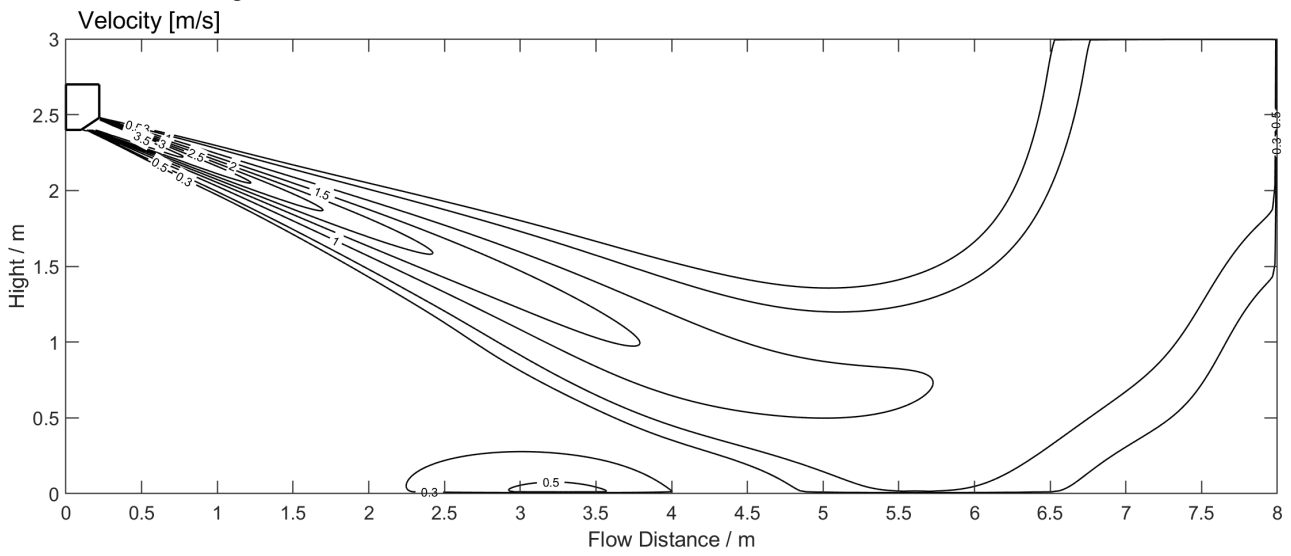

Temperature distributions

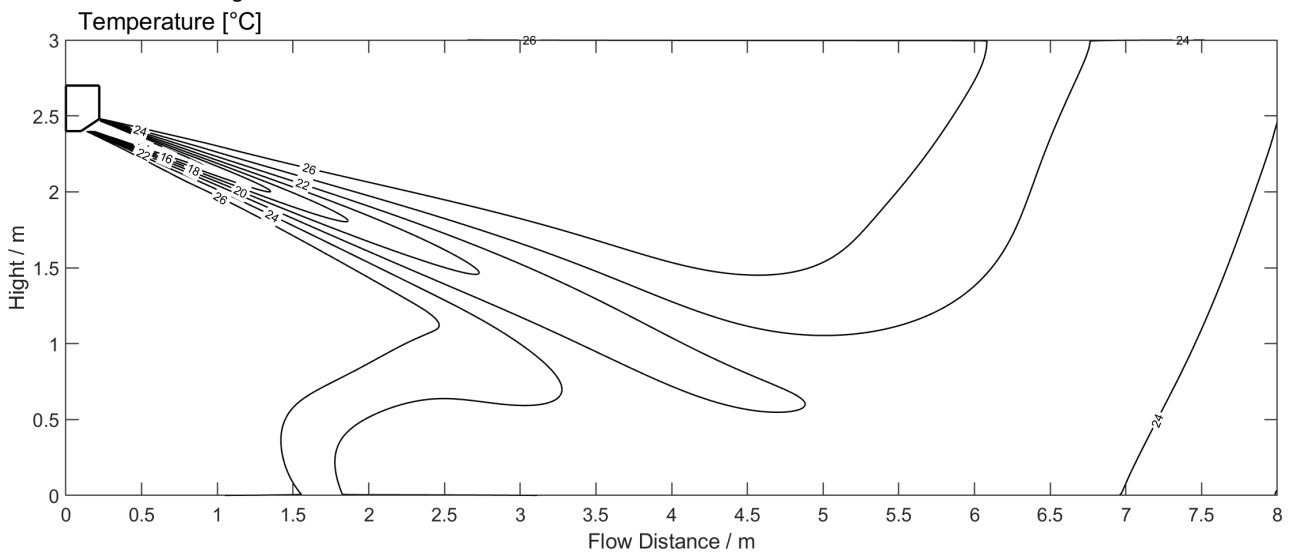

Heating(ID: 20°C/68°F, OD: 7°C/44.6°F)

Discharge Angle 68°

Airflow velocity distributions

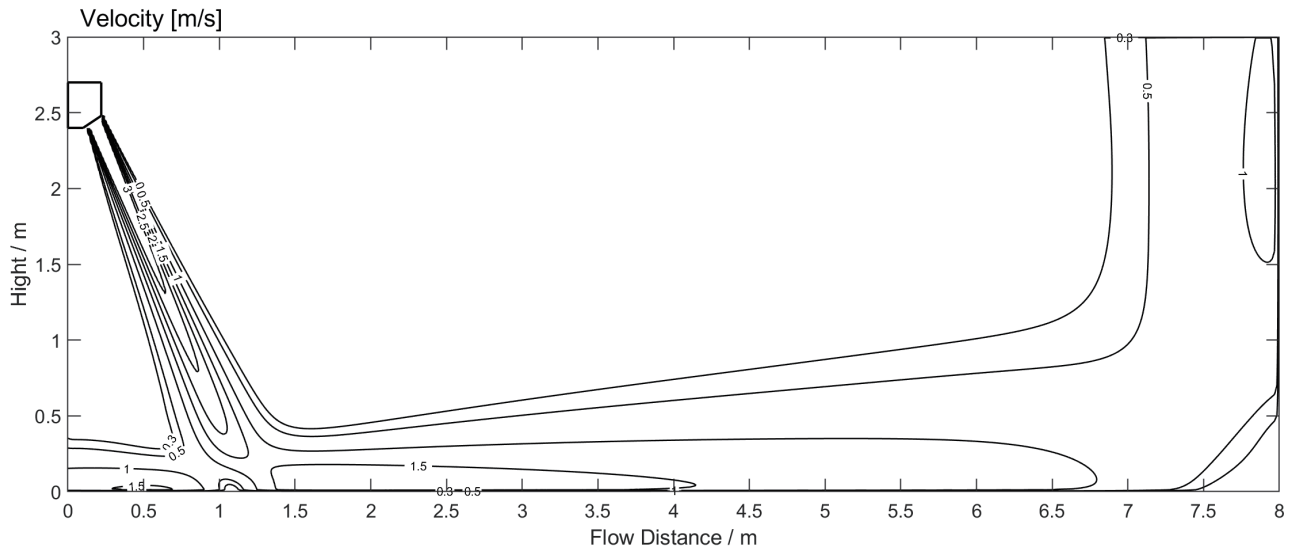

Temperature distributions

