

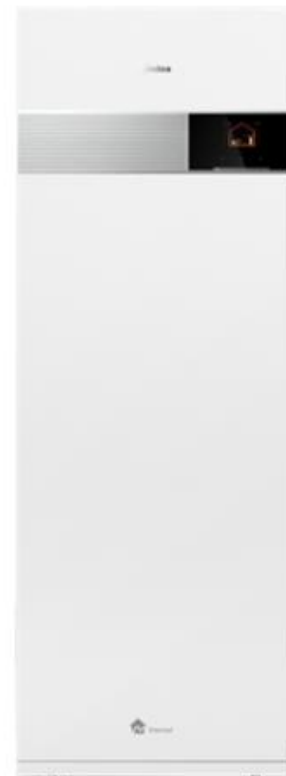

Midea Building Technologies Division

Engineering Reference Manual of Hygge Split

Midea M thermal



CONTENTS

Part 1 General Information.....	3
Part 2 Engineering Data	11

Part 1

General Information

1 M THERMAL SYSTEM	4
2 PRODUCT LINEUP.....	7
3 NOMENCLATURE.....	8
4 SYSTEM DESIGN AND UNIT SELECTION	10

1 M thermal System

1.1 System Schematic

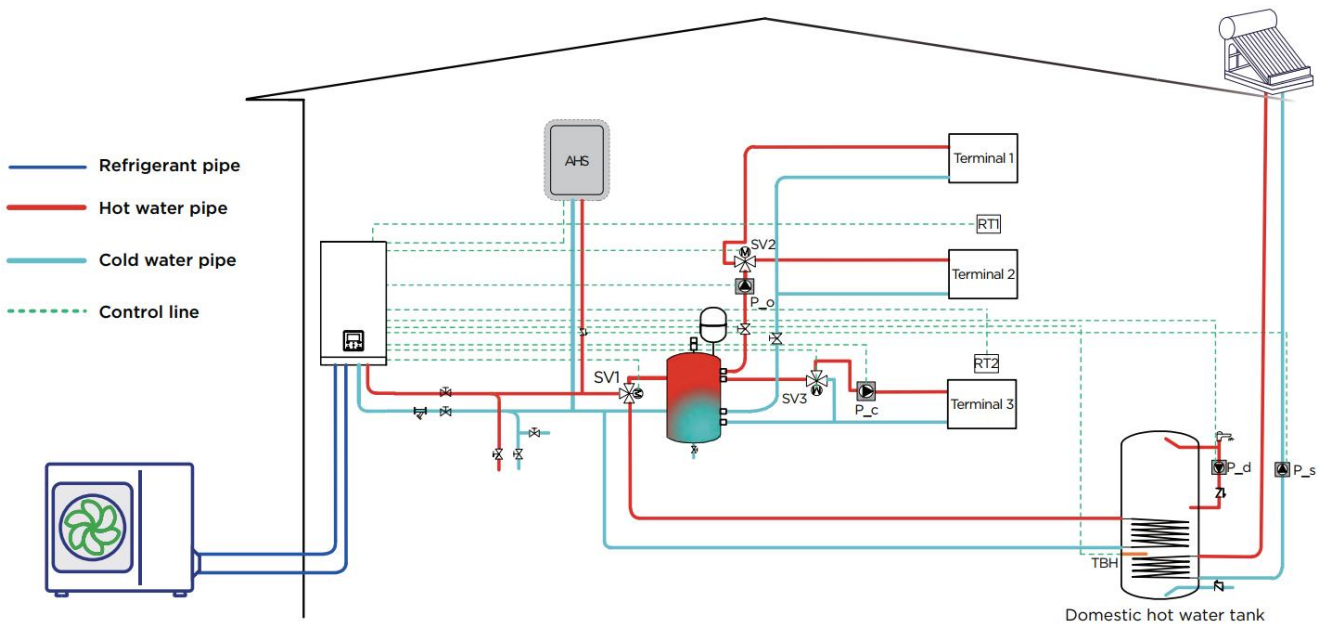

For hydraulic indoor unit without water tank

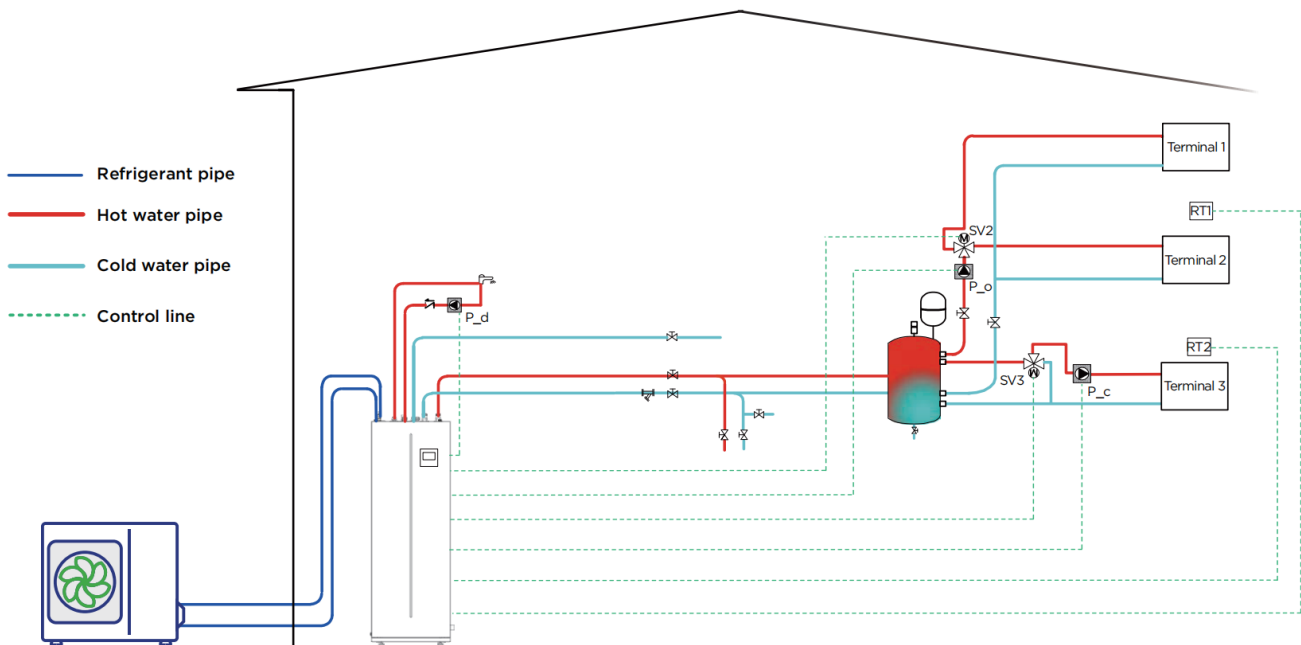

For hydraulic indoor unit with water tank

M thermal is an integrated air to water heat pump system which is one-stop solution for space heating, space cooling and domestic hot water, The outdoor heat pump system extracts heat from the outdoor air and transfers this heat through refrigerant piping to the plate heat exchanger in the hydronic system. The heated water in the hydronic system circulates to low temperature heat emitters (floor heating loops or low temperature radiators) to provide space heating, and to the domestic hot water tank to provide domestic hot water. The 4-way valve in the outdoor unit can reverse the refrigerant cycle so that the hydronic system can provide chilled water for cooling by fan coil units.

The heating capacity of heat pumps decreases with ambient temperature dropping. M thermal can be equipped with a backup electric heater to provide additional heating capacity for use during extremely cold weather when the heat pump capacity is insufficient. The backup electric heater also serves as a backup in case of heat pump malfunction and for

anti-freeze protection of the outside water piping in winter.

1.2 System Configurations

M thermal can be configured to run with the electric heater either enabled or disabled and can also be used in conjunction with an auxiliary heat source such as a boiler.

The chosen configuration affects the size of heat pump that is required. Three typical configurations are described below.

Configuration 1: Heat pump only

- The heat pump covers the required capacity and no extra heating capacity is necessary.
- Requires selection of larger capacity heat pump and implies higher initial investment.
- Ideal for new construction in projects where energy efficiency is paramount.

Configuration 2: Heat pump and backup electric heater

- Heat pump covers the required capacity until the ambient temperature drops below the point at which the heat pump is able to provide sufficient capacity. When the ambient temperature is below this equilibrium point (as shown below), the backup electric heater supplies the required additional heating capacity.
- Best balance between initial investment and running costs, results in lowest lifecycle cost.
- Ideal for new construction.



Configuration 3: Heat pump with auxiliary heat source

- Heat pump covers the required capacity until the ambient temperature drops below the point at which the heat pump is able to provide sufficient capacity. When the ambient temperature is below this equilibrium point (as shown below), depending on the system settings, either the auxiliary heat source supplies the required additional heating capacity or the heat pump does not run and the auxiliary heat source covers the required capacity.
- Enables selection of lower capacity heat pump.
- Ideal for refurbishments and upgrades.

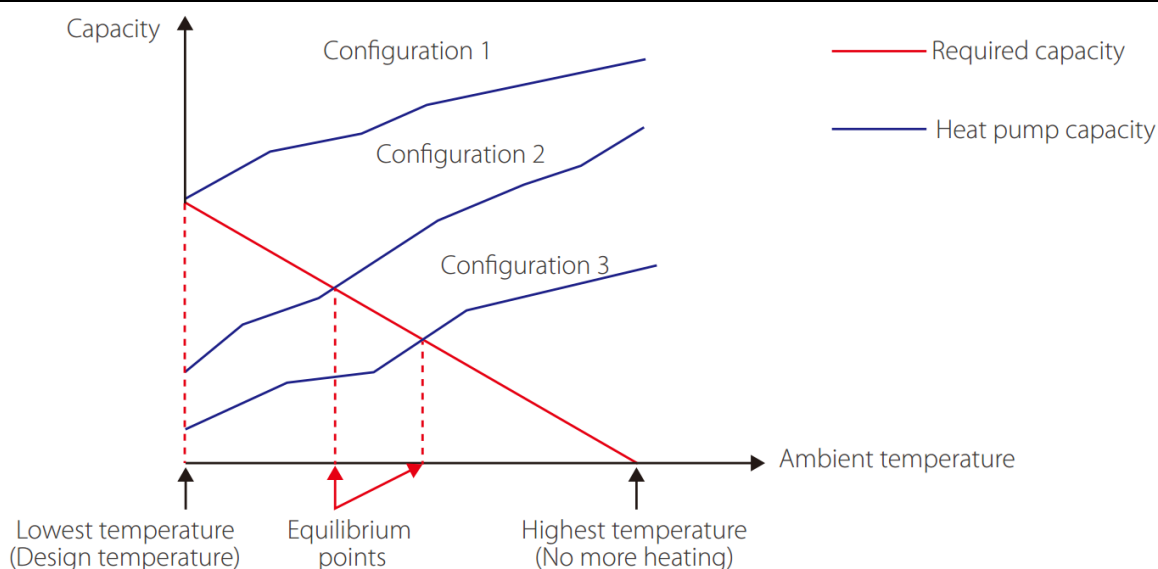
System configurations

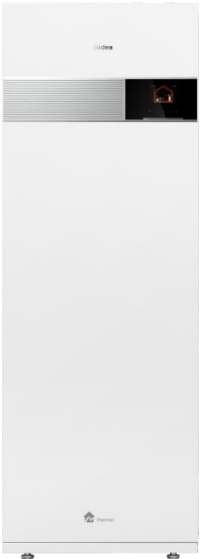

2 Product Lineup

Type	Model	Power supply	Appearance
Outdoor unit	MHA-V12WD2N8-E	220-240V/1N/50Hz	
	MHA-V14WD2N8-E	220-240V/1N/50Hz	
	MHA-V16WD2N8-E	220-240V/1N/50Hz	
	MHA-V12WD2RN8-E	380-415V~3N-50Hz	
	MHA-V14WD2RN8-E	380-415V~3N-50Hz	
	MHA-V16WD2RN8-E	380-415V~3N-50Hz	
Hydraulic indoor unit without water tank	HB-A160CGN8-E	220-240V/1N/50Hz	
	HB-A160CD30GN8-E	220-240V/1N/50Hz (E-heater 230V/1N/50Hz)	
	HB-A160CDS60GN8-E	220-240V/1N/50Hz (E-heater 400V/3N/50Hz)	
	HB-A160CDS90GN8-E	220-240V/1N/50Hz (E-heater 400V/3N/50Hz)	
Hydraulic indoor unit with water tank	HBT-A160240CD30GN8-E	220-240V/1N/50Hz	
	HBT-A160240CDS60GN8-E	220-240V/1N/50Hz (E-heater 400V/3N/50Hz)	
	HBT-A160240CDS90GN8-E	220-240V/1N/50Hz (E-heater 400V/3N/50Hz)	

3 Nomenclature

3.1 Outdoor unit

M	H	A	-	V	16	W	D2	R	N8	-	E
1	2	3		4	5	6	7	8	9		10

Legend		
No.	Code	Remarks
1	M	Brand: Midea brand
2	H	Unit type: heat pump
3	A	Structure: Split
4	V	System type: Inverter
5	16	Capacity Code: 16: 16 kW
6	W	Cooling type: Air cooling
7	D2	Compressor and fan motor types: All DC
8	R	Power Supply of heat pump R: 3-phase, 380-415V, 50Hz; Omitted: 1-phase, 220-240V, 50Hz
9	N8	Refrigerant: R32
10	E	Design code

3.2 Hydraulic indoor unit without water tank

HB	-	A	160	C	G	N8	-	E
1		2	3	4	5	6		7

Legend		
No.	Code	Remarks
1	HB	Hydraulic indoor unit without water tank
2	A	Compatible ODU: Split
3	160	Compatible maximum capacity of outdoor unit 160: 16 kW
4	C	Heating type: Water cycle with water pump
5	G	Function: Floor heating
6	N8	Refrigerant: R32
7	E	Design code

3.3 Hydraulic indoor unit with water tank

HBT	-	A	160	240	C	D	30	G	N8	-	E
1		2	3	4	5	6	7	8	9		10

Legend		
No.	Code	Remarks
1	HBT	Hydraulic indoor unit with water tank
2	A	Compatible ODU: Split
3	160	Compatible maximum capacity of outdoor unit 160: 16 kW
4	240	Tank volume 240: 240L
5	C	Heating type: Water cycle with water pump
6	D	Special function: Unit with E-heater
7	30	E-heater capacity 30: 3kW
8	G	Other function G: Floor heating function
9	N8	Refrigerant: R32
10	E	Design code

4 System Design and Unit Selection

4.1 Selection Procedure

Step 1: Total heat load calculation

Calculate conditioned surface area
Select the heat emitters (type, quantity, water temperature and heat load)

Step 2: System configuration

Decide whether to include AHS and set AHS's switching temperature
Decide whether backup electric heater is enabled or disabled

Step 3: Selection of outdoor units

Determine required total heat load on outdoor units
Set capacity safety factor
Select power supply

Provisionally select M thermal unit capacity based on nominal capacity

Correct capacity of the outdoor units for the following items:
Outdoor air temperature / Outdoor humidity / Water outlet temperature¹ /
Altitude / Anti-freeze fluid

Is corrected M thermal unit capacity \geq Required total heat load on outdoor units²

Yes

No

M thermal system selection is complete

Select a larger model or enable backup electric heater operation

Notes:

1. If the required water temperatures of the heat emitters are not all the same, the M thermal outlet water temperature setting should be set at the highest of the heat emitter required water temperatures. If the water outlet design temperature falls between two temperatures listed in the unit's capacity table, calculate the corrected capacity by interpolation.
2. If the unit selection is to be based on total heating load and total cooling load, select units which satisfy not only the total heating load requirements but also the total cooling load requirements.

4.2 Selection tool

Midea Heat pump selection website: <https://www.midea-hpselection.com>

Easy selection: For quick and simple unit selection without registration

Professional selection: For detailed and professional unit selection with registration and authorization.

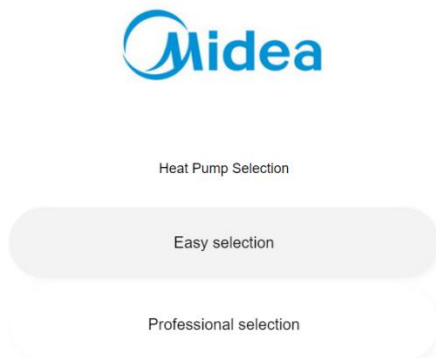

4.3 M thermal Leaving Water Temperature (LWT) Selection

The recommended design LTW ranges for different types of heat emitter are:

- For floor heating: 30 to 35°C
- For fan coil units: 30 to 45°C
- For low temperature radiators: 40 to 50°C

4.4 Optimizing System Design

To get the most comfort with the lowest energy consumption with M thermal, it is important to take account of the following considerations:

- Choose heat emitters that allow the heat pump system to operate at as low a hot water temperature as possible whilst still providing sufficient heating.
- Make sure the correct weather dependency curve is selected to match the installation environment (building structure, climate) as well as ender user's demands.
- Connecting room thermostat (supplied by user) to the hydronic system helps prevent excessive space heating by stopping the unit and circulation pump when the room temperature is above the thermostat set point.

Part 2

Engineering Data

1 SPECIFICATIONS	12
2 ELECTRICAL CHARACTERISTICS	21
3 DIMENSIONS AND CENTER OF GRAVITY	22
4 OPERATING LIMITS.....	25
5 HYDRONIC PERFORMANCE	27
6 CAPACITY TABLES	29
7 OCTAVE BAND SOUND LEVEL.....	40

1 Specifications

1.1 General

Outdoor unit			MHA-V12WD2N8-E MHA-V12WD2RN8-E	MHA-V14WD2N8-E MHA-V14WD2RN8-E	MHA-V16WD2N8-E MHA-V16WD2RN8-E
Indoor unit			HB-A160CGN8-E, HB-A160CD30GN8-E, HB-A160CD60GN8-E, HB-A160CD90GN8-E		
Heating A7W35	Capacity	kW	12.10	14.00	15.50
	Rated input	kW	2.40	2.89	3.36
	COP			5.04	4.84
Heating A7W45	Capacity	kW	12.10	14.00	15.50
	Rated input	kW	3.18	3.70	4.20
	COP			3.81	3.78
Heating A7W55	Capacity	kW	12.10	14.00	15.50
	Rated input	kW	4.02	4.67	5.18
	COP			3.01	3.00
Heating A2W35	Capacity	kW	12.10	14.00	15.50
	Rated input	kW	3.23	3.99	4.77
	COP			3.75	3.51
Heating A2W45	Capacity	kW	10.90	12.10	14.00
	Rated input	kW	3.49	3.96	4.82
	COP			3.14	3.06
Heating A2W55	Capacity	kW	11.60	12.30	13.80
	Rated input	kW	4.51	4.82	5.80
	COP			2.57	2.55
Heating A-7W35	Capacity	kW	12.10	14.00	15.50
	Rated input	kW	3.97	4.93	5.78
	COP			3.05	2.84
Heating A-7W45	Capacity	kW	11.40	11.90	13.70
	Rated input	kW	4.49	4.70	5.61
	COP			2.54	2.53
Heating A-7W55	Capacity	kW	11.40	11.90	13.70
	Rated input	kW	5.38	5.61	6.46
	COP			2.12	2.12
Heating A-15W35	Capacity	kW	12.10	14.00	15.50
	Rated input	kW	4.82	5.71	6.65
	COP			2.51	2.45
Cooling A35W18	Capacity	kW	10.00		
	Rated input	kW	2.35		
	EER			4.25	
Cooling A35W7	Capacity	kW	10.00		
	Rated input	kW	3.32		
	EER			3.01	
Seasonal space heating energy efficiency class	Water outlet at 35°C	ηs	204.60%	199.40%	194.00%
		Class	A+++		
	Water outlet at 55°C	ηs	153.60%	152.20%	151.00%
		Class	A+++		

1.1 General

Outdoor unit			MHA-V12WD2N8-E MHA-V12WD2RN8-E	MHA-V14WD2N8-E MHA-V14WD2RN8-E	MHA-V16WD2N8-E MHA-V16WD2RN8-E
Indoor unit			HB-A160CGN8-E, HB-A160CD30GN8-E, HB-A160CD60GN8-E, HB-A160CD90GN8-E		
SCOP	Warmer climate	35°C	6.38	6.49	6.48
		55°C	4.34	4.35	4.35
	Average climate	35°C	5.19	5.06	4.93
		55°C	3.92	3.88	3.85
	Colder climate	35°C	4.55	4.56	4.55
		55°C	3.19	3.27	3.35
Seasonal space cooling energy efficiency class	Water outlet at 7°C	ηs	212.90%		
	Water outlet at 18°C	ηs	257.20%		
SEER	Water outlet at 7°C		5.40		
	Water outlet at 18°C		6.51		
Rated water flow	m³/h		2.05	2.40	2.70
Water flow range	m³/h		0.50-3.00		
Internal water volume(without backup heater)	L		2.90		
Internal water volume(with backup heater)	L		4.00		
Refrigerant side piping	Connection		Screw	Screw	Screw
	Liquid Dia.(OD)	mm	9.52		
	Gas Dia.(OD)	mm	15.9		
	Refrigerant		R32		
	Factory charged	kg	1.84		
	Non-charge refrigerant piping length	m	15		
	Refrigerant to be added	g/m	38		
	Maximum pipe length	m	30		
	Maximum height difference	m	20		
Water side piping	Connection		Screw		
	Inlet dimension	Inch	R1"		
	Outlet dimension	Inch	R1"		
	Drainage pipe connection	mm	DN25		
Ambient temperature range	Cooling	°C	-5 ~ 43		
	Heating	°C	-28 ~ 35		
	DHW	°C	-28 ~ 43		
Water setting temperature range	Cooling	°C	5~25		
	Heating	°C	25~65		
	DHW	°C	20~60		

1.1 General

Outdoor unit			MHA-V12WD2N8-E MHA-V12WD2RN8-E	MHA-V14WD2N8-E MHA-V14WD2RN8-E	MHA-V16WD2N8-E MHA-V16WD2RN8-E
Indoor unit			HBT-A160240CD30GN8-E, HBT-A160240CDS60GN8-E, HBT-A160240CDS90GN8-E		
Heating A7W35	Capacity	kW	12.10	14.00	15.50
	Rated input	kW	2.40	2.89	3.36
	COP		5.04	4.84	4.61
Heating A7W45	Capacity	kW	12.10	14.00	15.50
	Rated input	kW	3.18	3.70	4.20
	COP		3.81	3.78	3.69
Heating A7W55	Capacity	kW	12.10	14.00	15.50
	Rated input	kW	4.02	4.67	5.18
	COP		3.01	3.00	2.99
Heating A2W35	Capacity	kW	12.10	14.00	15.50
	Rated input	kW	3.23	3.99	4.77
	COP		3.75	3.51	3.25
Heating A2W45	Capacity	kW	10.90	12.10	14.00
	Rated input	kW	3.49	3.96	4.82
	COP		3.14	3.06	2.90
Heating A2W55	Capacity	kW	11.60	12.30	13.80
	Rated input	kW	4.51	4.82	5.80
	COP		2.57	2.55	2.38
Heating A-7W35	Capacity	kW	12.10	14.00	15.50
	Rated input	kW	3.97	4.93	5.78
	COP		3.05	2.84	2.68
Heating A-7W45	Capacity	kW	11.40	11.90	13.70
	Rated input	kW	4.49	4.70	5.61
	COP		2.54	2.53	2.44
Heating A-7W55	Capacity	kW	11.40	11.90	13.70
	Rated input	kW	5.38	5.61	6.46
	COP		2.12	2.12	2.12
Heating A-15W35	Capacity	kW	12.10	14.00	15.50
	Rated input	kW	4.82	5.71	6.65
	COP		2.51	2.45	2.33
Cooling A35W18	Capacity	kW	10.00		
	Rated input	kW	2.35		
	EER		4.25		
Cooling A35W7	Capacity	kW	10.00		
	Rated input	kW	3.32		
	EER		3.01		
Seasonal space heating energy efficiency class	Water outlet at 35°C	ηs	204.60%	199.40%	194.00%
		Class	A+++		
	Water outlet at 55°C	ηs	153.60%	152.20%	151.00%
		Class	A+++		

1.1 General

Outdoor unit			MHA-V12WD2N8-E MHA-V12WD2RN8-E	MHA-V14WD2N8-E MHA-V14WD2RN8-E	MHA-V16WD2N8-E MHA-V16WD2RN8-E
Indoor unit			HBT-A160240CD30GN8-E, HBT-A160240CDS60GN8-E, HBT-A160240CDS90GN8-E		
SCOP	Warmer climate	35°C	6.38	6.49	6.48
		55°C	4.34	4.35	4.35
	Average climate	35°C	5.19	5.06	4.93
		55°C	3.92	3.88	3.85
	Colder climate	35°C	4.55	4.56	4.55
		55°C	3.19	3.27	3.35
Seasonal space cooling energy efficiency class	Water outlet at 7°C	ηs	212.90%		
	Water outlet at 18°C	ηs	257.20%		
SEER	Water outlet at 7°C		5.40		
	Water outlet at 18°C		6.51		
Domestic hot water heating	Declared load profile		XL		
Domestic hot water heating energy efficiency class	Warm climate	ηwh	153%	153%	153%
		class	A+		
		COP	3.82	3.82	3.82
	Average climate	ηwh	136%	136%	136%
		class	A+		
		COP	3.40	3.40	3.40
	Cold climate	ηwh	114%	114%	114%
		class	A		
		COP	2.84	2.84	2.84
Rated water flow	m ³ /h		2.05	2.40	2.70
Water flow range	m ³ /h		0.50-3.00		
Internal water volume(without backup heater)	L		2.90		
Internal water volume(with backup heater)	L		4.00		
Refrigerant side piping	Connection		Screw	Screw	Screw
	Liquid Dia.(OD)	mm	9.52		
	Gas Dia.(OD)	mm	15.9		
	Refrigerant		R32		
	Factory charged	kg	1.84		
	Non-charge refrigerant piping length	m	15		
	Refrigerant to be added	g/m	38		
	Maximum pipe length	m	30		
Maximum height difference	m	20			

1.1 General

Outdoor unit			MHA-V12WD2N8-E MHA-V12WD2RN8-E	MHA-V14WD2N8-E MHA-V14WD2RN8-E	MHA-V16WD2N8-E MHA-V16WD2RN8-E
Indoor unit			HBT-A160240CD30GN8-E, HBT-A160240CDS60GN8-E, HBT-A160240CDS90GN8-E		
Water side piping	Connection		Screw		
	Inlet dimension	Inch	R1"		
	Outlet dimension	Inch	R1"		
	Drainage pipe connection	mm	DN25		
Ambient temperature range	Cooling	°C	-5 ~ 43		
	Heating	°C	-28 ~ 35		
	DHW	°C	-28 ~ 43		
Water setting temperature range	Cooling	°C	5~25		
	Heating	°C	25~65		
	DHW	°C	20~60		
Return water temperature range	Cooling	°C	5~25		
	Heating	°C	25~65		
	DHW	°C	20~60		

Note:

- The above data test reference standard EN14511; EN14825

1.2 Outdoor unit

Outdoor unit		MHA-V12WD2N8-E	MHA-V14WD2N8-E	MHA-V16WD2N8-E
Power supply(V/Ph/Hz)		220-240/1/50	220-240/1/50	220-240/1/50
Erp sound power level		dB	59	60
Sound power level ¹	Heating A7W35	dB	59	60
	Heating max A-7W35	dB	60	61
	Heating silent mode 1	dB	54	55
	Heating silent mode 2	dB	51	51
	Cooling A35W18	dB	59	60
	Cooling max A35W7	dB	59	60
	Cooling silent mode1	dB	54	54
	Cooling silent mode2	dB	51	51
Sound pressure Level (1m/2m/3m)	Heating A7W35	dB(A)	45/41/38	45/42/39
	Heating max A-7W55	dB(A)	47/44/41	47/44/41
	Heating silent mode 1	dB(A)	42/39/35	43/40/37
	Heating silent mode 2	dB(A)	40/37/33	40/37/35
	Cooling A35W18	dB(A)	44/41/39	44/41/39
	Cooling max A35W7	dB(A)	46/44/40	46/44/40
	Cooling silent mode1	dB(A)	41/37/34	41/38/35
	Cooling silent mode2	dB(A)	38/35/32	39/36/33
Compressor	Type	DC twin rotary		
Fan	Type	DC motor		
	Number	1		
	Air flow	m ³ /h	4780	
Air side heat exchanger	Type	Fin coil		
Throttle	Type	Electronic expansion valve		
Unit dimension (W×H×D)		mm	1051*1330*475	
Packing dimension (W×H×D)		mm	1235*1390*570	
Net weight		kg	121	
Gross weight		kg	144	

Note:

1. Sound power measured according to EN12102-1

1.2 Outdoor unit

Outdoor unit		MHA-V12WD2RN8-E	MHA-V14WD2RN8-E	MHA-V16WD2RN8-E
Power supply(V/Ph/Hz)		380-415/3/50	380-415/3/50	380-415/3/50
Erp sound power level		dB	59	60
Sound power level ¹	Heating A7W35	dB	59	60
	Heating max A-7W35	dB	60	61
	Heating silent mode 1	dB	54	55
	Heating silent mode 2	dB	51	51
	Cooling A35W18	dB	59	60
	Cooling max A35W7	dB	59	60
	Cooling silent mode1	dB	54	54
	Cooling silent mode2	dB	51	51
Sound pressure Level (1m/2m/3m)	Heating A7W35	dB(A)	45/41/38	45/42/39
	Heating max A-7W35	dB(A)	47/44/41	47/44/41
	Heating silent mode 1	dB(A)	42/39/35	43/40/37
	Heating silent mode 2	dB(A)	40/37/33	40/37/35
	Cooling A35W18	dB(A)	44/41/39	44/41/39
	Cooling max A35W7	dB(A)	46/44/40	46/44/40
	Cooling silent mode1	dB(A)	41/37/34	41/38/35
	Cooling silent mode2	dB(A)	38/35/32	39/36/33
Compressor	Type	DC twin rotary		
Fan	Type	DC motor		
	Number	1		
	Air flow	m ³ /h	4780	
Air side heat exchanger	Type	Fin coil		
Throttle	Type	Electronic expansion valve		
Unit dimension (W×H×D)		mm	1051*1330*475	
Packing dimension (W×H×D)		mm	1235*1390*570	
Net weight		kg	130.5	
Gross weight		kg	153.5	

Note:

1. Sound power measured according to EN12102-1

1.3 Indoor unit

Indoor unit			HB-A160CGN8-E	HB-A160CD30GN8-E	HB-A160CD60GN8-E	HB-A160CD90GN8-E
Power supply(V/Ph/Hz)			220-240/1/50	220-240/1/50	220-240/1/50	220-240/1/50
Erp sound power level		dB	43	43	43	43
Sound power level ¹	Heating A7W35	dB	43	43	43	43
	Heating max A-7W35	dB	43	43	43	43
	heating silent mode 1	dB	40	40	40	40
	heating silent mode 2	dB	40	40	40	40
	Cooling A35W18	dB	45	45	45	45
	Cooling max A35W7	dB	45	45	45	45
	Cooling silent mode1	dB	41	41	41	41
	Cooling silent mode2	dB	41	41	41	41
Sound pressure Level(1m/2m)	Heating A7W35	dB(A)	32/30	32/30	32/30	32/30
	Heating max A-7W35	dB(A)	32/30	32/30	32/30	32/30
	Heating silent mode 1	dB(A)	29/27	29/27	29/27	29/27
	Heating /2m mode 2	dB(A)	29/27	29/27	29/27	29/27
	Cooling A35W18	dB(A)	34/31	34/31	34/31	34/31
	Cooling max A35W7	dB(A)	34/31	34/31	34/31	34/31
	Cooling silent mode 1	dB(A)	31/29	31/29	31/29	31/29
	Cooling silent mode 2	dB(A)	31/29	31/29	31/29	31/29
Water side heat exchanger	Type		Plate	Plate	Plate	Plate
Water pump	Type		DC Inverter	DC Inverter	DC Inverter	DC Inverter
	Maximum pump head	m	9	9	9	9
Expansion vessel	Nominal Volume	L	8	8	8	8
	Actual Volume	L	5	5	5	5
	Charge pressure	Mpa	0.15	0.15	0.15	0.15
Backup E-heater	Standard mounted	kW	/	3	6	9
	Capacity steps		/	1-step	2-steps	3-steps
	Power supply	V/Ph/Hz	/	230/1/50	400/3/50	400/3/50
Safety valve	MPa		0.3	0.3	0.3	0.3
Flow switch	m ³ /h		0.6	0.6	0.6	0.6
Unit dimension (W×H×D)		mm	420*790*270	420*790*270	420*790*270	420*790*270
Packing dimension (W×H×D)		mm	525*1050*360	525*1050*360	525*1050*360	525*1050*360
Net weight		kg	33	33	33	33
Gross weight		kg	37	37	37	37

1.3 Indoor unit

Indoor unit		HBT-A160240CD30GN8-E	HBT-A160240CD60GN8-E	HBT-A160240CD90GN8-E
Power supply(V/Ph/Hz)		220-240/1/50	220-240/1/50	220-240/1/50
Erp sound power level		dB	44	44
Sound power level ¹	Heating A7W35	dB	41.1	41.1
	Heating max A-7W35	dB	40.9	40.9
	Heating silent mode 1	dB	/	/
	Heating silent mode 2	dB	/	/
	Cooling A35W18	dB	44	44
	Cooling max A35W7	dB	44.7	44.7
	Cooling silent mode1	dB	/	/
	Cooling silent mode2	dB	/	/
Sound pressure Level(1m/2m)	Heating A7W35	dB(A)	26/24	26/24
	Heating max A-7W35	dB(A)	32/29	32/29
	Heating silent mode 1	dB(A)	/	/
	Heating silent mode 2	dB(A)	/	/
	Cooling A35W18	dB(A)	29/27	29/27
	Cooling max A35W7	dB(A)	33/30	33/30
	Cooling silent mode 1	dB(A)	/	/
	Cooling silent mode 2	dB(A)	/	/
Water side heat exchanger		Plate type	Plate type	Plate type
Water pump	Type	DC Inverter	DC Inverter	DC Inverter
	Maximum pump head	m	9	9
Expansion vessel	Nominal Volume	L	8	8
	Actual Volume	L	5	5
	Max. working pressure	bar	3	3
	Pre-charge pressure	Mpa	3	3
DHW Tank	Tank material		stainless steel	stainless steel
	Tank material grade		SUS 316L	SUS 316L
	Nominal Volume	L	240	240
	Actual Volume	L	240	240
	Max. water temperature	°C	70	70
	Max. water pressure limit	bar	10	10
	Insulation material		Polyurethane (Cyclopentane)	
	Insulation thickness	mm	45	45
Backup E-heater	Standard mounted	kW	3	6
	Capacity steps		1-step	2-steps
	Power supply	V/Ph/Hz	230/1/50	400/3/50
Safety valve	MPa	0.3	0.3	0.3
Flow switch	m ³ /h	0.36	0.36	0.36
Unit dimension (W×H×D)		mm	600*1943*600	600*1943*600
Packing dimension (W×H×D)		mm	730*2180*730	730*2180*730
Net weight		kg	159	159
Gross weight		kg	180	180

Note:

Sound power measured according to EN12102-1

2 Electrical characteristics

System	Unit			Power current		Compressor		Fan		Pump	
	Power supply	Min. (V)	Max. (V)	MCA (A)	MFA (A)	MSC (A)	RLA (A)	kW	FLA (A)	kW	FLA (A)
MHA-V12WD2N8-E	220~240/1N/50Hz	198	264	32	40	/	18.5	0.1	0.45	/	/
MHA-V14WD2N8-E	220~240/1N/50Hz	198	264	32	40	/	18.5	0.1	0.45	/	/
MHA-V16WD2N8-E	220~240/1N/50Hz	198	264	32	40	/	18.5	0.1	0.45	/	/
MHA-V12WD2RN8-E	380~415/3N/50Hz	342	456	13	16	/	18	0.1	0.45	/	/
MHA-V14WD2RN8-E	380~415/3N/50Hz	342	456	13	16	/	18	0.1	0.45	/	/
MHA-V16WD2RN8-E	380~415/3N/50Hz	342	456	13	16	/	18	0.1	0.45	/	/
HB-A160CGN8-E	220~240/1N/50Hz	198	264	1.2	10	/	/	/	/	0.087	0.66
HB-A160CD30GN8-E	220~240/1N/50Hz	198	264	1.2	10	/	/	/	/	0.087	0.66
HB-A160CD60GN8-E	220~240/1N/50Hz	198	264	1.2	10	/	/	/	/	0.087	0.66
HB-A160CD90GN8-E	220~240/1N/50Hz	198	264	1.2	10	/	/	/	/	0.087	0.66
HBT-A160240CD30GN8-E	220~240/1N/50Hz	198	264	16.9	20	/	/	/	/	0.005~0.09	0.8
HBT-A160240CD60GN8-E	220~240/1N/50Hz	198	264	16.9	20	/	/	/	/	0.005~0.09	0.8
HBT-A160240CD90GN8-E	220~240/1N/50Hz	198	264	16.9	20	/	/	/	/	0.005~0.09	0.8

Notes:

Name	Description	Explanation
Min. & Max.	Minimum & Maximum running voltage (V)	Required voltage range for system operation
MCA	Min. Circuit Amps. (A)	To determine the minimum wire diameter
MFA	Max. Fuse Amps. (A)	To determine air-break switch /circuit breaker/ Fuse
MSC	Max. Starting Amps. (A)	The starting current of the inverter compressor is very small and can be ignored.
RLA	Rated Load Amps. (A)	The input Amps of compressor where MAX. Hz can operate for nominal cooling or heating test condition
kW	Rated Motor Output	/
FLA	Full Load Amps. (A)	The current measured by the motor at rated voltage and rated speed (usually the highest speed of Motor) under rated load.

3 Dimensions and Center of Gravity

3.1 Outdoor unit

12-16kW

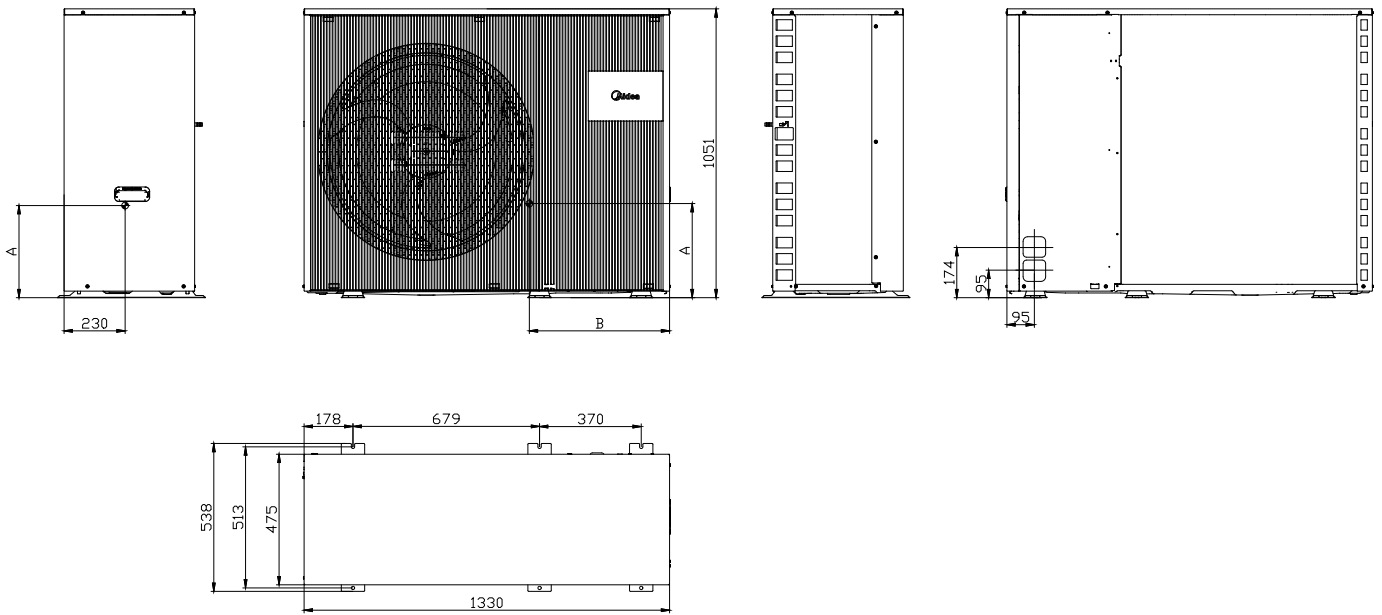

unit: mm

Model	A	B
1 phase 12/14/16kW	351	530
3 phase 12/14/16kW	347	490

3.2 Indoor unit

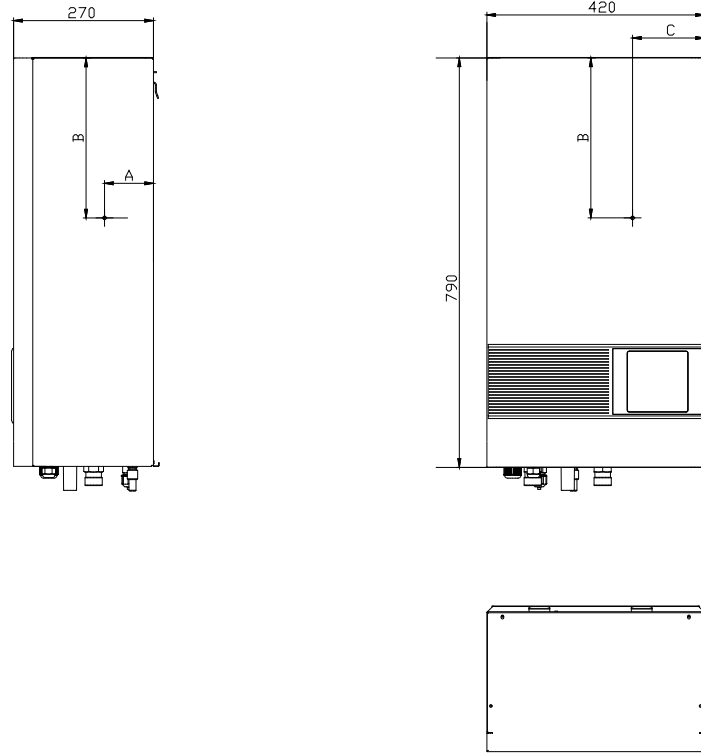

unit: mm

Model	A	B	C
HB-A160	123	320	180

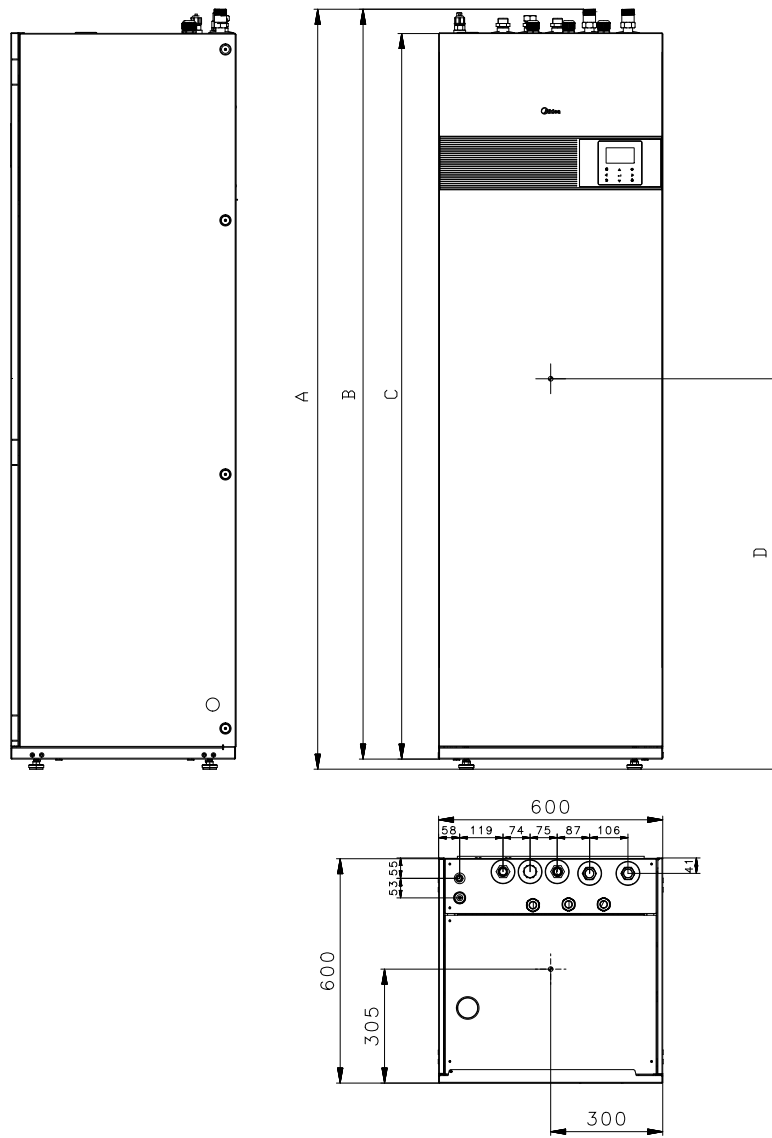

unit: mm

Model	A	B	C	D
HBT-A160240	2034	2007	1942	1045

4 Operating Limits

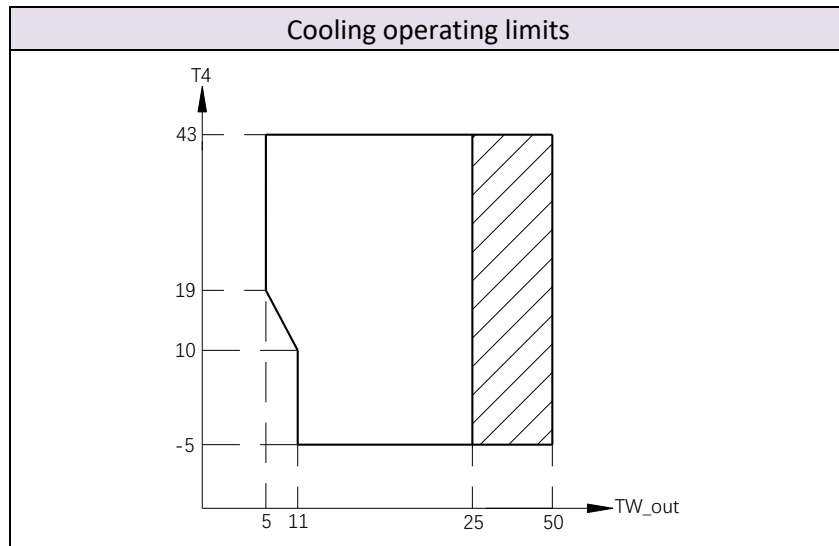
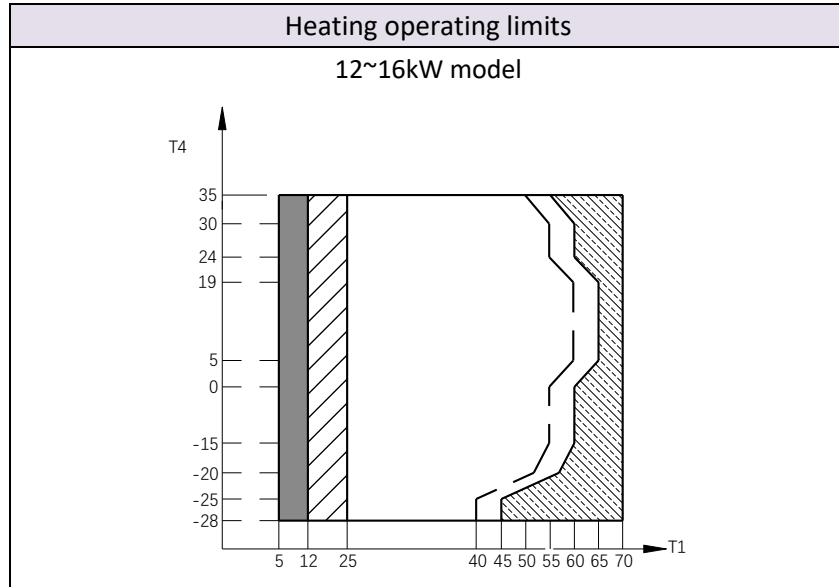

Notes:

1. If IBH/AHS setting is valid, only IBH/AHS turns on; if IBH/AHS setting is invalid, only heat pump turns on. Limitation and protection may occur during heat pump operation.
2. Operation range by heat pump with possible limitation and protection.
3. Heat pump turns off, only IBH/AHS on.
4. — —Maximum inlet water temperature line for heat pump operation.
5. TW_out: Leaving water temperature (°C)
T1: Backup heater outlet water temperature (°C)
T4: Outdoor ambient temperature (°C)
IBH: Internal backup heater
AHS: Auxiliary heating source

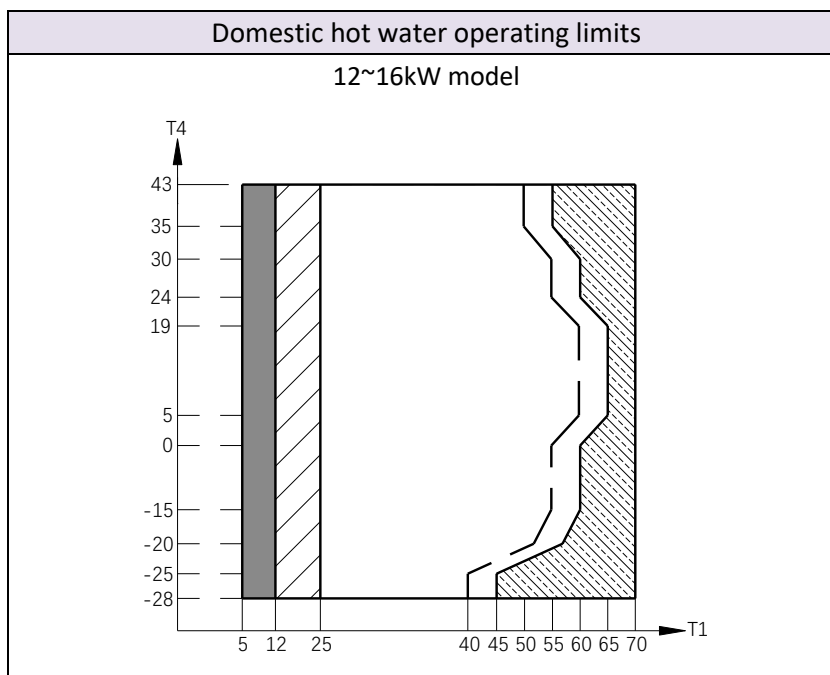

- Notes:
1. If IBH/AHS setting is valid, only IBH/AHS turns on; if IBH/AHS setting is invalid, only heat pump turns on. Limitation and protection may occur during heat pump operation.
 2. Operation range by heat pump with possible limitation and protection.
 3. Heat pump turns off, only IBH/AHS on.
 4. — —Maximum inlet water temperature line for heat pump operation.
 5. TW_out: Leaving water temperature (°C)
T1: Backup heater outlet water temperature (°C)
T4: Outdoor ambient temperature (°C)
IBH: Internal backup heater
AHS: Auxiliary heating source

5 Hydronic Performance

HB-A160 model

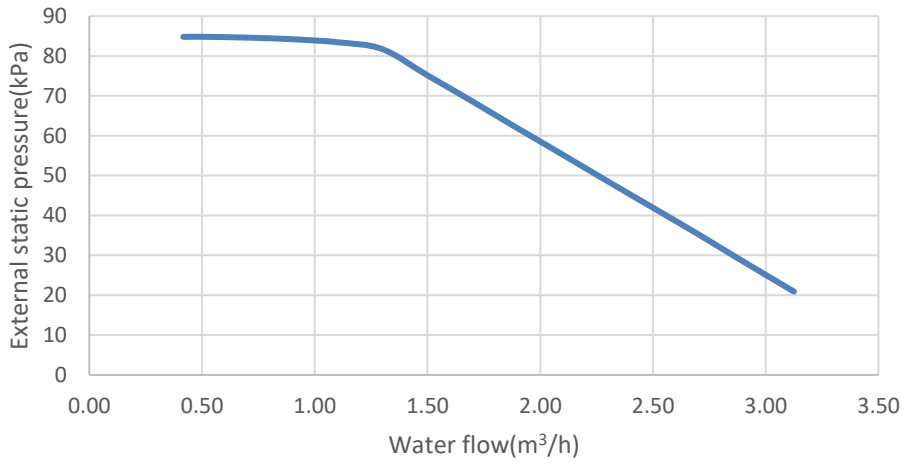

HBT-A160240 model

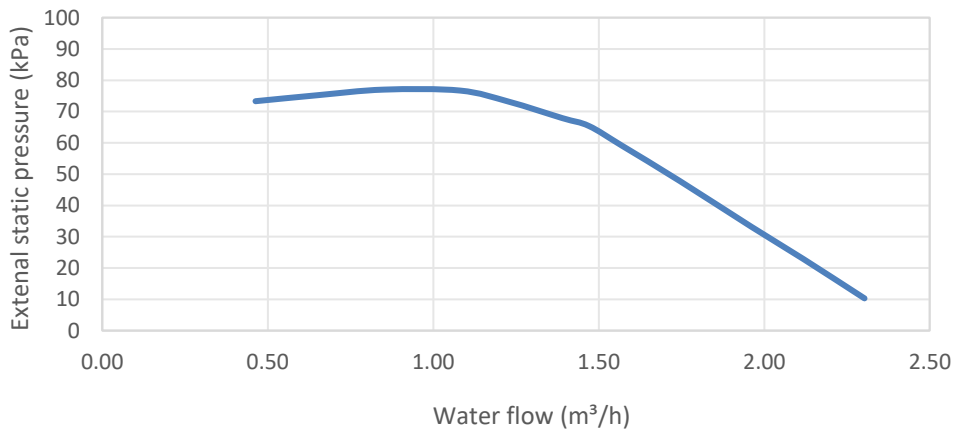

Hygge Split



Performance curves in domestic hot water production

MHA-V12(14,16)WD2(R)N8-E + HBT-A160240CD30GN8-E

Heat up

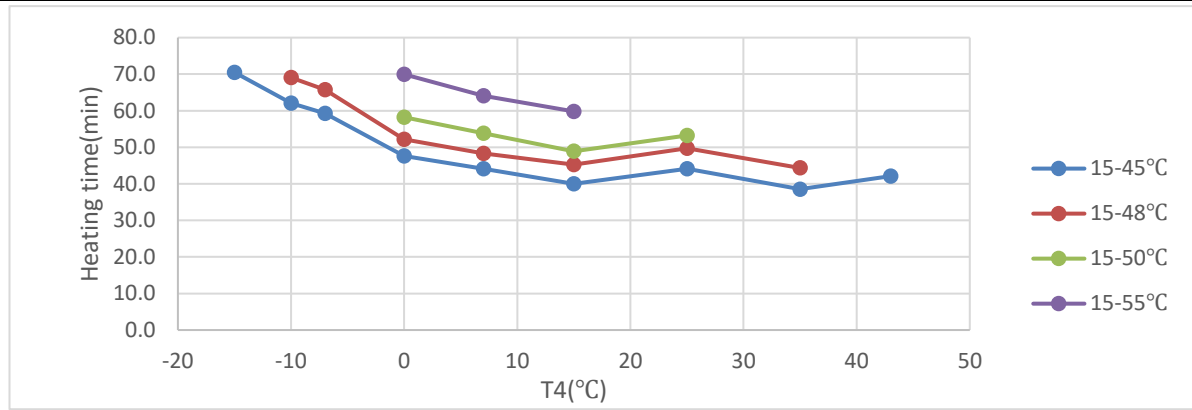

Capacity

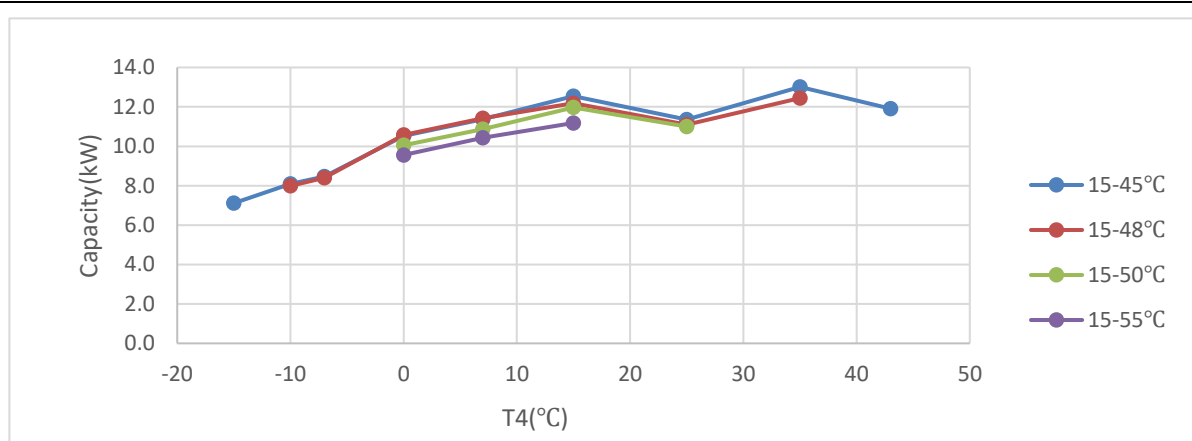

COP

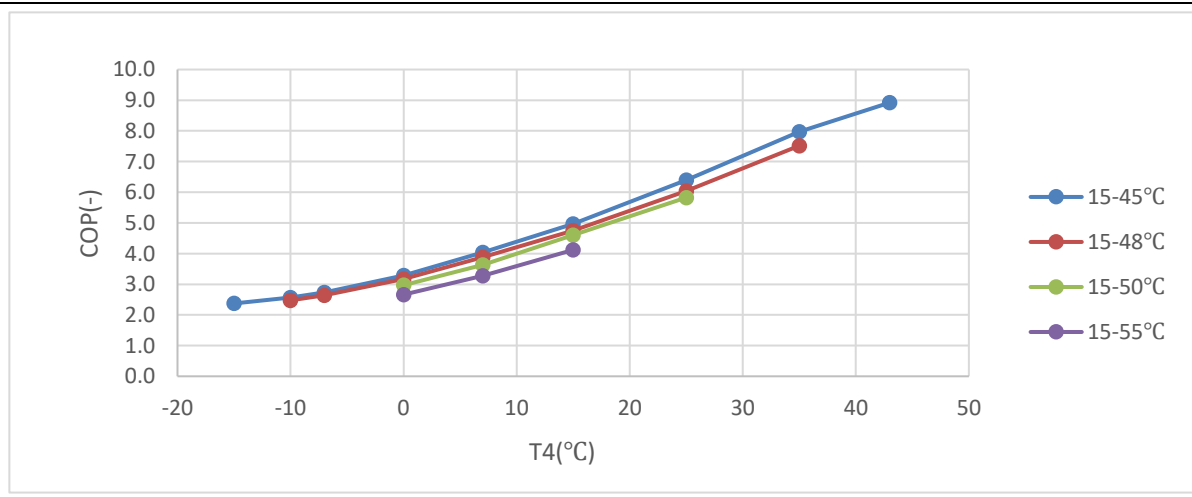

6 Capacity Tables

6.1 Heating Capacity Tables (Test standard: EN14511)

12kW model heating capacity

LWT	DB	Maximum			100%(Normal)			75%			50%			25%			Minimum		
		HC	COP	PI	HC	COP	PI	HC	COP	PI	HC	COP	PI	HC	COP	PI	HC	COP	PI
25	-28	7.93	2.28	3.48	7.71	2.39	3.23	4.56	2.53	1.80	4.56	2.53	1.80	4.23	2.56	1.65	4.23	2.56	1.65
	-20	9.33	2.59	3.60	9.12	2.60	3.51	6.80	2.72	2.50	5.43	2.79	1.95	5.11	2.83	1.81	5.11	2.83	1.81
	-15	10.95	2.94	3.72	9.37	2.66	3.52	8.52	3.20	2.66	6.42	3.30	1.95	6.42	3.30	1.95	6.42	3.30	1.95
	-10	12.16	3.42	3.56	11.69	3.14	3.72	8.43	3.54	2.38	6.91	3.62	1.91	6.91	3.62	1.91	6.91	3.62	1.91
	-7	13.11	3.85	3.41	11.40	3.71	3.07	8.44	3.96	2.13	7.93	3.97	2.00	7.93	3.97	2.00	7.93	3.97	2.00
	-5	13.62	4.10	3.32	11.92	3.96	3.01	8.44	4.14	2.04	6.42	4.24	1.51	6.35	4.25	1.49	6.35	4.25	1.49
	-2	14.23	4.58	3.11	12.01	4.40	2.73	8.31	4.58	1.81	6.32	4.71	1.34	6.32	4.71	1.34	6.32	4.71	1.34
	0	14.75	4.92	3.00	12.12	4.66	2.60	8.19	4.86	1.68	6.69	4.94	1.35	6.69	4.94	1.35	6.69	4.94	1.35
	2	14.82	5.35	2.77	11.66	4.99	2.34	8.50	5.16	1.65	6.90	5.24	1.32	6.90	5.24	1.32	6.90	5.24	1.32
	5	14.54	6.11	2.38	11.23	5.57	2.02	8.30	6.05	1.37	7.09	6.06	1.17	7.09	6.06	1.17	7.09	6.06	1.17
	7	14.90	6.65	2.24	12.18	7.45	1.63	8.26	7.65	1.08	7.51	7.69	0.98	7.51	7.69	0.98	7.51	7.69	0.98
	10	15.11	7.72	1.96	12.10	8.45	1.43	8.47	8.63	0.98	7.62	8.67	0.88	7.62	8.67	0.88	7.62	8.67	0.88
	12	15.00	8.87	1.69	11.87	9.33	1.27	8.46	9.47	0.89	8.16	9.55	0.85	8.16	9.55	0.85	8.16	9.55	0.85
	15	13.17	9.43	1.40	11.89	9.50	1.25	8.52	9.60	0.89	8.23	9.65	0.85	8.12	9.66	0.84	8.12	9.66	0.84
	20	11.88	10.14	1.17	11.50	10.11	1.14	8.31	10.25	0.81	7.99	10.31	0.78	7.89	10.34	0.76	7.89	10.34	0.76
	25	12.71	11.68	1.09	12.28	11.55	1.06	8.85	11.72	0.75	8.45	11.74	0.72	8.15	11.75	0.69	8.15	11.75	0.69
30	/	/	/	/	/	/	/	/	/	/	/	/	/	/	/	/	/	/	/
35	/	/	/	/	/	/	/	/	/	/	/	/	/	/	/	/	/	/	/
30	-28	9.42	2.42	3.90	7.81	2.45	3.19	5.22	2.51	2.08	5.18	2.52	2.06	5.11	2.53	2.02	5.11	2.53	2.02
	-20	10.86	2.68	4.05	9.70	2.52	3.85	6.80	2.66	2.56	6.09	2.71	2.25	5.89	2.74	2.15	5.89	2.74	2.15
	-15	12.47	2.97	4.20	10.80	2.59	4.17	8.69	2.91	2.99	7.06	2.94	2.40	6.50	2.95	2.20	6.50	2.95	2.20
	-10	13.53	3.33	4.06	12.04	3.11	3.87	8.19	3.30	2.48	7.29	3.32	2.20	7.15	3.33	2.15	7.15	3.33	2.15
	-7	14.46	3.71	3.90	11.45	3.55	3.22	8.53	3.72	2.29	7.69	3.74	2.06	7.59	3.77	2.01	7.59	3.77	2.01
	-5	13.36	3.75	3.56	11.25	3.61	3.11	8.42	3.73	2.26	8.23	3.75	2.19	8.15	3.80	2.14	8.15	3.80	2.14
	-2	13.95	4.13	3.38	11.77	3.91	3.01	8.39	4.11	2.04	6.00	4.23	1.42	5.91	4.26	1.39	5.91	4.26	1.39
	0	14.46	4.40	3.29	11.88	4.12	2.88	8.44	4.41	1.91	6.38	4.51	1.41	6.35	4.52	1.40	6.35	4.52	1.40
	2	14.51	4.73	3.07	11.81	4.26	2.77	8.58	4.45	1.93	6.68	4.55	1.47	6.55	4.57	1.43	6.55	4.57	1.43
	5	14.19	5.20	2.73	12.18	5.26	2.32	8.50	5.44	1.56	6.77	5.52	1.23	6.43	5.55	1.16	6.43	5.55	1.16
	7	14.36	5.32	2.70	12.36	5.73	2.16	8.46	5.93	1.43	7.01	6.01	1.17	6.87	6.04	1.14	6.87	6.04	1.14
	10	14.72	6.16	2.39	12.62	6.30	2.00	8.40	6.51	1.29	7.36	6.55	1.12	7.32	6.56	1.12	7.32	6.56	1.12
	12	14.64	6.82	2.15	12.13	7.22	1.68	8.48	7.42	1.14	7.90	7.45	1.06	7.85	7.46	1.05	7.85	7.46	1.05
	15	12.81	7.21	1.78	12.44	7.28	1.71	8.26	7.79	1.06	7.97	7.80	1.02	7.92	7.81	1.01	7.92	7.81	1.01
	20	11.55	8.07	1.43	11.16	8.10	1.38	8.37	8.24	1.02	7.75	8.27	0.94	7.70	8.28	0.93	7.70	8.28	0.93
	25	12.39	9.22	1.34	12.32	9.18	1.34	8.62	9.36	0.92	8.62	9.36	0.92	8.57	9.37	0.91	8.57	9.37	0.91
30	13.50	10.42	1.30	12.26	10.47	1.17	9.18	10.62	0.86	9.18	10.62	0.86	9.03	10.63	0.85	9.03	10.63	0.85	
35	/	/	/	/	/	/	/	/	/	/	/	/	/	/	/	/	/	/	/
35	-28	9.42	2.22	4.25	5.84	2.19	2.67	5.10	2.23	2.29	4.98	2.25	2.21	4.85	2.26	2.15	4.85	2.26	2.15
	-20	10.87	2.44	4.46	9.66	2.44	3.96	6.72	2.59	2.59	5.91	2.63	2.25	5.54	2.65	2.09	5.54	2.65	2.09
	-15	12.48	2.71	4.61	12.10	2.51	4.82	8.59	2.78	3.09	6.91	2.82	2.45	6.83	2.83	2.41	6.83	2.83	2.41
	-10	13.47	3.03	4.45	12.09	2.84	4.26	8.43	3.02	2.79	8.06	3.04	2.65	7.95	3.09	2.57	7.95	3.09	2.57
	-7	14.39	3.36	4.28	12.10	3.05	3.97	8.46	3.22	2.63	8.26	3.26	2.53	8.16	3.27	2.50	8.16	3.27	2.50
	-5	14.83	3.53	4.20	12.02	3.21	3.74	8.94	3.36	2.66	8.54	3.50	2.44	8.12	3.52	2.31	8.12	3.52	2.31
	-2	15.31	3.84	3.99	12.05	3.44	3.50	8.39	3.62	2.32	5.94	3.83	1.55	5.91	3.85	1.53	5.91	3.85	1.53
	0	15.76	4.05	3.89	12.09	3.59	3.37	8.35	3.77	2.21	6.06	4.08	1.49	6.06	4.08	1.48	6.06	4.08	1.48
	2	15.73	4.30	3.66	12.10	3.75	3.23	8.37	3.93	2.13	6.41	4.13	1.55	6.37	4.14	1.54	6.37	4.14	1.54
	5	15.26	4.65	3.28	12.18	4.61	2.64	8.44	4.79	1.76	6.92	4.87	1.42	6.44	4.89	1.32	6.44	4.89	1.32
	7	14.26	4.81	2.96	12.10	5.04	2.40	8.39	5.24	1.60	6.90	5.31	1.30	6.86	5.32	1.29	6.86	5.32	1.29
	10	14.43	5.28	2.73	12.17	5.51	2.21	8.47	5.58	1.52	7.05	5.68	1.24	7.05	5.68	1.24	7.05	5.68	1.24
	12	14.39	5.77	2.49	12.16	6.02	2.02	8.51	6.21	1.37	7.66	6.44	1.19	7.61	6.45	1.18	7.61	6.45	1.18
	15	12.54	6.05	2.08	12.13	6.07	2.00	8.30	6.55	1.27	7.75	6.63	1.17	7.65	6.64	1.15	7.65	6.64	1.15
	20	12.31	6.50	1.89	12.08	6.70	1.80	8.43	6.88	1.23	7.53	7.08	1.06	7.29	7.09	1.03	7.29	7.09	1.03
	25	12.13	7.56	1.61	12.05	7.51	1.60	8.41	7.69	1.09	8.41	7.69	1.09	8.15	7.71	1.06	8.15	7.71	1.06
30	13.24	8.44	1.57	12.00	8.55	1.40	9.18	8.69	1.06	9.18	8.69	1.06	9.01	8.71	1.03	9.01	8.71	1.03	
35	13.16	9.82	1.34	11.89	9.99	1.19	10.01	10.11	0.99	10.01	10.11	0.99	9.74	10.13	0.96	9.74	10.13	0.96	

LWT	DB	Maximum			100%(Normal)			75%			50%			25%			Minimum		
		HC	COP	PI	HC	COP	PI	HC	COP	PI	HC	COP	PI	HC	COP	PI	HC	COP	PI
40	-28	9.45	1.99	4.75	5.58	2.13	2.62	5.14	2.15	2.39	5.14	2.15	2.39	5.08	2.16	2.35	5.08	2.16	2.35
	-20	10.91	2.19	4.99	9.65	2.18	4.43	6.70	2.33	2.87	6.00	2.39	2.51	6.00	2.39	2.51	6.00	2.39	2.51
	-15	12.52	2.42	5.17	11.81	2.41	4.89	8.24	2.52	3.27	6.96	2.59	2.69	6.96	2.59	2.69	6.96	2.59	2.69
	-10	13.46	2.71	4.97	11.61	2.55	4.56	8.23	2.84	2.90	8.04	2.86	2.81	8.04	2.86	2.81	8.04	2.86	2.81
	-7	14.39	3.01	4.78	11.76	2.90	4.05	8.46	3.06	2.77	8.36	3.08	2.71	8.26	3.09	2.67	8.26	3.09	2.67
	-5	14.81	3.17	4.67	11.68	3.07	3.80	8.94	3.21	2.79	8.62	3.23	2.67	8.62	3.23	2.67	8.62	3.23	2.67
	-2	15.27	3.44	4.44	11.61	3.28	3.54	8.53	3.43	2.49	7.38	3.48	2.12	7.38	3.48	2.12	7.38	3.48	2.12
	0	15.71	3.61	4.35	11.58	3.40	3.41	8.00	3.52	2.27	7.77	3.53	2.20	7.77	3.53	2.20	7.77	3.53	2.20
	2	15.66	3.85	4.07	11.04	3.50	3.15	8.08	3.68	2.20	7.95	3.69	2.15	7.95	3.69	2.15	7.95	3.69	2.15
	5	15.19	4.15	3.66	11.84	4.17	2.84	8.68	4.30	2.02	6.23	4.39	1.42	6.23	4.39	1.42	6.23	4.39	1.42
	7	15.45	4.36	3.54	11.88	4.41	2.69	8.85	4.53	1.95	6.64	4.65	1.43	6.64	4.65	1.43	6.64	4.65	1.43
	10	15.54	4.74	3.28	11.94	4.82	2.48	8.36	5.01	1.67	6.81	5.09	1.34	6.81	5.09	1.34	6.81	5.09	1.34
	12	15.52	5.17	3.00	11.92	5.27	2.26	8.28	5.45	1.52	7.44	5.49	1.36	7.44	5.49	1.36	7.44	5.49	1.36
	15	13.46	5.31	2.54	11.99	5.35	2.24	8.37	5.48	1.53	7.52	5.52	1.36	7.52	5.52	1.36	7.52	5.52	1.36
	20	11.07	5.64	1.96	10.68	5.63	1.90	8.51	5.75	1.48	7.34	5.81	1.26	7.34	5.81	1.26	7.34	5.81	1.26
	25	11.92	6.32	1.88	11.84	6.29	1.88	8.21	6.49	1.26	8.21	6.49	1.26	8.21	6.49	1.26	8.21	6.49	1.26
30	13.03	7.06	1.84	11.77	7.10	1.66	8.98	7.27	1.24	8.98	7.27	1.24	8.98	7.27	1.24	8.98	7.27	1.24	
35	14.22	8.09	1.76	12.05	8.27	1.46	9.82	8.57	1.15	9.15	8.71	1.05	9.15	8.71	1.05	9.15	8.71	1.05	
45	-28	9.49	1.78	5.34	5.61	1.87	3.01	5.58	1.88	2.97	5.51	1.88	2.93	5.51	1.88	2.93	5.51	1.88	2.93
	-20	10.98	1.96	5.60	9.43	1.95	4.84	6.73	2.08	3.24	6.39	2.09	3.06	6.39	2.09	3.06	6.39	2.09	3.06
	-15	12.59	2.17	5.82	10.70	2.16	4.96	7.96	2.31	3.44	7.33	2.34	3.13	7.33	2.34	3.13	7.33	2.34	3.13
	-10	13.47	2.41	5.59	11.43	2.27	5.03	8.45	2.42	3.49	8.31	2.43	3.42	8.31	2.43	3.42	8.31	2.43	3.42
	-7	14.40	2.69	5.35	11.40	2.54	4.49	9.29	2.72	3.42	9.19	2.73	3.37	9.19	2.73	3.37	9.19	2.73	3.37
	-5	14.82	2.83	5.24	11.34	2.78	4.08	9.84	2.85	3.45	9.73	2.86	3.40	9.73	2.86	3.40	9.73	2.86	3.40
	-2	15.28	3.09	4.94	11.06	2.99	3.70	9.31	3.08	3.02	9.31	3.08	3.02	9.31	3.08	3.02	9.31	3.08	3.02
	0	15.71	3.25	4.83	11.03	3.11	3.55	9.68	3.19	3.04	9.68	3.19	3.04	9.68	3.19	3.04	9.68	3.19	3.04
	2	15.65	3.44	4.55	10.90	3.14	3.47	9.76	3.22	3.03	9.76	3.22	3.03	9.76	3.22	3.03	9.76	3.22	3.03
	5	15.20	3.72	4.09	11.57	3.79	3.05	8.13	3.96	2.05	6.85	4.02	1.70	6.85	4.02	1.70	6.85	4.02	1.70
	7	15.45	3.91	3.95	12.10	3.81	3.18	8.65	4.01	2.16	7.33	4.07	1.80	7.33	4.07	1.80	7.33	4.07	1.80
	10	15.54	4.24	3.66	12.18	4.23	2.88	8.38	4.42	1.90	7.06	4.49	1.57	7.06	4.49	1.57	7.06	4.49	1.57
	12	15.62	4.67	3.35	12.19	4.60	2.65	8.30	4.81	1.72	7.76	4.84	1.60	7.76	4.84	1.60	7.76	4.84	1.60
	15	13.47	4.71	2.86	11.90	4.65	2.56	8.47	4.74	1.79	7.87	4.77	1.65	7.39	4.88	1.51	7.39	4.88	1.51
	20	11.78	4.86	2.42	11.33	4.84	2.34	8.28	4.99	1.66	7.71	5.01	1.54	7.71	5.01	1.54	7.71	5.01	1.54
	25	12.59	5.40	2.33	12.10	5.39	2.25	8.65	5.50	1.57	8.65	5.50	1.57	8.65	5.50	1.57	8.65	5.50	1.57
30	12.81	6.01	2.13	11.93	6.00	1.99	9.49	6.12	1.55	9.49	6.12	1.55	9.49	6.12	1.55	9.49	6.12	1.55	
35	12.69	7.00	1.81	12.16	6.99	1.74	10.37	7.09	1.46	10.19	7.11	1.43	10.19	7.11	1.43	10.19	7.11	1.43	
50	-28	/	/	/	/	/	/	/	/	/	/	/	/	/	/	/	/	/	/
	-20	11.04	1.75	6.29	9.12	1.75	5.21	6.38	1.92	3.33	6.19	1.93	3.21	6.01	1.95	3.08	6.01	1.95	3.08
	-15	12.66	1.94	6.52	11.44	1.93	5.92	8.00	2.11	3.80	8.00	2.11	3.80	7.94	2.12	3.75	7.94	2.12	3.75
	-10	12.82	2.17	5.91	10.81	1.99	5.43	9.21	2.14	4.30	9.11	2.16	4.22	7.89	2.36	3.34	7.89	2.36	3.34
	-7	14.41	2.41	5.98	11.48	2.35	4.88	9.73	2.46	3.96	9.63	2.47	3.90	9.55	2.48	3.85	9.55	2.48	3.85
	-5	14.11	2.57	5.49	11.37	2.50	4.55	10.28	2.57	4.00	10.28	2.57	4.00	10.21	2.61	3.91	10.21	2.61	3.91
	-2	15.27	2.76	5.53	11.10	2.71	4.09	10.59	2.75	3.86	10.39	2.80	3.71	10.33	2.81	3.68	10.33	2.81	3.68
	0	15.70	2.92	5.38	11.44	2.79	4.10	10.95	2.82	3.88	10.85	2.83	3.83	10.65	2.90	3.67	10.65	2.90	3.67
	2	15.64	3.08	5.08	11.46	2.85	4.03	11.16	2.87	3.89	10.35	2.89	3.59	10.15	2.91	3.49	10.15	2.91	3.49
	5	15.20	3.34	4.55	11.58	3.41	3.39	9.60	3.51	2.74	8.55	3.58	2.39	8.55	3.58	2.39	8.55	3.58	2.39
	7	15.44	3.51	4.40	12.21	3.56	3.43	9.13	3.72	2.46	9.03	3.73	2.42	8.92	3.74	2.39	8.92	3.74	2.39
	10	15.54	3.80	4.09	12.10	3.75	3.22	8.08	3.96	2.04	7.24	3.98	1.82	7.19	4.04	1.78	7.19	4.04	1.78
	12	15.71	4.19	3.75	12.09	4.05	2.99	8.28	4.12	2.01	8.01	4.13	1.94	7.96	4.15	1.92	7.96	4.15	1.92
	15	13.45	4.16	3.23	12.10	4.09	2.96	8.39	4.26	1.97	8.13	4.27	1.90	8.08	4.28	1.89	8.08	4.28	1.89
	20	11.62	4.24	2.74	11.15	4.20	2.65	8.29	4.32	1.92	8.01	4.33	1.85	7.96	4.34	1.83	7.96	4.34	1.83
	25	12.39	4.69	2.64	11.88	4.65	2.56	9.00	4.79	1.88	9.00	4.79	1.88	8.94	4.80	1.86	8.94	4.80	1.86
30	13.50	5.24	2.58	11.62	5.17	2.25	9.88	5.30	1.86	9.88	5.30	1.86	9.81	5.39	1.82	9.81	5.39	1.82	
35	12.34	6.07	2.03	12.25	6.05	2.03	10.81	6.25	1.73	10.81	6.25	1.73	10.72	6.26	1.71	10.72	6.26	1.71	

LWT	DB	Maximum			100%(Normal)			75%			50%			25%			Minimum		
		HC	COP	PI	HC	COP	PI	HC	COP	PI	HC	COP	PI	HC	COP	PI	HC	COP	PI
55	-28	/	/	/	/	/	/	/	/	/	/	/	/	/	/	/	/	/	/
	-20	10.47	1.60	6.54	8.21	1.65	4.98	6.59	1.62	4.07	6.38	1.63	3.91	6.01	1.71	3.51	6.01	1.71	3.51
	-15	11.71	1.78	6.57	10.81	1.84	5.88	6.78	1.64	4.13	6.58	1.69	3.89	6.11	1.74	3.51	6.11	1.74	3.51
	-10	12.39	2.02	6.13	10.98	2.01	5.46	7.02	1.76	3.99	6.18	1.86	3.32	6.18	1.86	3.32	6.18	1.86	3.32
	-7	13.97	2.26	6.18	11.40	2.12	5.38	10.67	2.22	4.80	10.59	2.23	4.75	10.19	2.24	4.54	10.19	2.24	4.54
	-5	13.44	2.42	5.55	11.40	2.28	5.00	11.03	2.33	4.73	10.55	2.35	4.49	10.16	2.37	4.29	10.16	2.37	4.29
	-2	14.14	2.61	5.42	11.67	2.41	4.84	11.05	2.44	4.53	10.95	2.45	4.47	10.45	2.47	4.23	10.45	2.47	4.23
	0	14.90	2.74	5.44	11.62	2.51	4.63	11.09	2.59	4.28	10.38	2.60	3.99	9.49	2.64	3.60	9.49	2.64	3.60
	2	15.87	2.85	5.57	11.60	2.57	4.51	9.95	2.63	3.78	9.51	2.64	3.60	7.86	2.72	2.89	7.86	2.72	2.89
	5	15.41	3.09	4.99	11.75	2.88	4.08	9.93	2.91	3.41	9.51	3.08	3.09	9.13	3.10	2.95	9.13	3.10	2.95
	7	15.66	3.24	4.83	12.10	3.01	4.02	9.51	3.20	2.97	9.45	3.25	2.91	8.58	3.28	2.62	8.58	3.28	2.62
	10	15.72	3.49	4.51	12.18	3.44	3.54	9.01	3.45	2.61	8.82	3.50	2.52	8.58	3.51	2.44	8.58	3.51	2.44
	12	15.95	3.84	4.16	12.15	3.70	3.28	9.56	3.74	2.56	9.11	3.75	2.43	8.26	3.77	2.19	8.26	3.77	2.19
	15	13.56	3.79	3.58	12.10	3.74	3.24	9.17	3.81	2.41	8.62	3.82	2.26	7.42	3.84	1.93	7.42	3.84	1.93
	20	11.58	3.82	3.03	11.12	3.82	2.91	8.37	3.83	2.19	8.11	3.88	2.09	7.94	3.90	2.04	7.94	3.90	2.04
25	12.32	4.24	2.91	11.83	4.33	2.73	9.42	4.36	2.16	9.42	4.36	2.16	9.17	4.52	2.03	9.17	4.52	2.03	
30	13.42	4.75	2.83	11.50	4.71	2.44	10.35	4.74	2.18	10.35	4.74	2.18	10.11	4.75	2.13	10.11	4.75	2.13	
35	12.16	5.55	2.19	12.10	5.54	2.18	11.35	5.63	2.02	11.35	5.63	2.02	11.11	5.64	1.97	11.11	5.64	1.97	
60	-28	/	/	/	/	/	/	/	/	/	/	/	/	/	/	/	/	/	/
	-20	/	/	/	/	/	/	/	/	/	/	/	/	/	/	/	/	/	/
	-15	10.16	1.67	6.09	6.89	1.48	4.66	6.25	1.54	4.06	6.15	1.55	3.97	6.05	1.56	3.88	6.05	1.56	3.88
	-10	10.76	1.75	6.15	7.10	1.51	4.69	6.45	1.56	4.13	6.35	1.57	4.04	6.25	1.58	3.96	6.25	1.58	3.96
	-7	12.31	1.99	6.18	10.77	2.01	5.36	10.53	2.02	5.21	10.41	2.03	5.13	10.11	2.06	4.91	10.11	2.06	4.91
	-5	11.52	2.12	5.42	11.02	2.05	5.38	10.95	2.07	5.29	10.95	2.07	5.29	10.32	2.10	4.91	10.32	2.10	4.91
	-2	12.18	2.25	5.42	11.28	2.28	4.95	10.54	2.32	4.54	10.39	2.34	4.44	10.39	2.34	4.44	10.39	2.34	4.44
	0	12.48	2.30	5.42	11.41	2.34	4.88	10.87	2.36	4.60	10.79	2.37	4.55	10.19	2.41	4.23	10.19	2.41	4.23
	2	12.62	2.36	5.35	11.38	2.36	4.83	11.07	2.40	4.61	10.89	2.42	4.50	10.15	2.46	4.13	10.15	2.46	4.13
	5	15.01	2.75	5.46	12.00	2.81	4.27	10.27	2.82	3.64	10.22	2.84	3.60	10.02	2.85	3.52	10.02	2.85	3.52
	7	15.18	2.87	5.29	12.33	2.92	4.22	10.45	3.07	3.40	10.15	3.09	3.28	10.04	3.11	3.23	10.04	3.11	3.23
	10	15.14	3.07	4.93	12.47	3.06	4.08	10.43	3.24	3.22	10.16	3.29	3.09	10.08	3.31	3.05	10.08	3.31	3.05
	12	14.41	3.45	4.18	12.06	3.35	3.60	11.28	3.38	3.34	10.12	3.42	2.96	9.06	3.43	2.64	9.06	3.43	2.64
	15	13.10	3.39	3.87	12.10	3.38	3.58	8.97	3.56	2.52	8.67	3.59	2.42	8.43	3.61	2.34	8.43	3.61	2.34
	20	11.06	3.42	3.24	10.64	3.59	2.96	8.44	3.71	2.27	8.44	3.71	2.27	8.44	3.71	2.27	8.44	3.71	2.27
25	11.59	3.74	3.10	11.20	3.77	2.97	9.00	3.88	2.32	9.00	3.88	2.32	8.78	3.89	2.26	8.78	3.89	2.26	
30	12.61	4.22	2.99	12.18	4.26	2.86	9.85	4.37	2.25	9.85	4.37	2.25	9.54	4.38	2.18	9.54	4.38	2.18	
35	/	/	/	/	/	/	/	/	/	/	/	/	/	/	/	/	/	/	/
65	-28	/	/	/	/	/	/	/	/	/	/	/	/	/	/	/	/	/	/
	-20	/	/	/	/	/	/	/	/	/	/	/	/	/	/	/	/	/	/
	-15	/	/	/	/	/	/	/	/	/	/	/	/	/	/	/	/	/	/
	-10	/	/	/	/	/	/	/	/	/	/	/	/	/	/	/	/	/	/
	-7	/	/	/	/	/	/	/	/	/	/	/	/	/	/	/	/	/	/
	-5	/	/	/	/	/	/	/	/	/	/	/	/	/	/	/	/	/	/
	-2	/	/	/	/	/	/	/	/	/	/	/	/	/	/	/	/	/	/
	0	/	/	/	/	/	/	/	/	/	/	/	/	/	/	/	/	/	/
	2	/	/	/	/	/	/	/	/	/	/	/	/	/	/	/	/	/	/
	5	13.40	2.46	5.44	11.58	2.46	4.70	9.18	2.56	3.59	9.08	2.57	3.53	8.98	2.58	3.48	8.98	2.58	3.48
	7	14.05	2.57	5.48	11.24	2.54	4.43	9.55	2.62	3.65	9.41	2.63	3.58	9.01	2.65	3.40	9.01	2.65	3.40
	10	13.75	2.69	5.11	10.10	2.82	3.58	9.53	2.84	3.36	9.11	2.88	3.16	9.06	2.89	3.13	9.06	2.89	3.13
	12	11.85	2.87	4.12	10.55	2.89	3.66	10.02	2.91	3.44	9.95	2.92	3.41	9.85	2.95	3.34	9.85	2.95	3.34
	15	11.94	2.90	4.12	11.87	2.97	4.00	8.47	2.95	2.87	8.39	2.99	2.81	8.39	2.99	2.81	8.39	2.99	2.81
	20	/	/	/	/	/	/	/	/	/	/	/	/	/	/	/	/	/	/
25	/	/	/	/	/	/	/	/	/	/	/	/	/	/	/	/	/	/	/
30	/	/	/	/	/	/	/	/	/	/	/	/	/	/	/	/	/	/	/
35	/	/	/	/	/	/	/	/	/	/	/	/	/	/	/	/	/	/	/

Abbreviations:

LWT: Leaving water temperature (°C)

DB: Dry-bulb temperature for Outdoor air temperature (°C)

HC: Total heating capacity (kW) PI: Power input (kW)

14kW model heating capacity

LWT	DB	Maximum			100%(Normal)			75%			50%			25%			Minimum		
		HC	COP	PI	HC	COP	PI	HC	COP	PI	HC	COP	PI	HC	COP	PI	HC	COP	PI
25	-28	9.34	2.35	3.97	9.23	2.04	4.52	5.36	2.42	2.22	5.36	2.42	2.22	4.33	2.47	1.75	4.33	2.47	1.75
	-20	10.91	2.63	4.15	10.65	2.55	4.18	7.84	2.69	2.92	6.26	2.77	2.26	5.21	2.82	1.85	5.21	2.82	1.85
	-15	12.71	2.93	4.34	12.01	2.60	4.62	9.80	2.74	3.58	7.32	2.84	2.58	7.21	2.85	2.53	7.21	2.85	2.53
	-10	14.39	3.30	4.36	13.87	3.03	4.58	9.82	3.23	3.04	7.67	3.35	2.29	7.45	3.36	2.22	7.45	3.36	2.22
	-7	15.32	3.63	4.22	13.86	3.67	3.78	9.87	3.87	2.55	8.79	3.93	2.24	8.79	3.93	2.24	8.79	3.93	2.24
	-5	15.84	3.84	4.13	13.90	3.89	3.57	9.68	4.11	2.36	9.35	4.13	2.26	9.25	4.14	2.23	9.25	4.14	2.23
	-2	16.88	4.24	3.98	14.35	4.32	3.33	10.02	4.54	2.21	7.04	4.69	1.50	7.04	4.69	1.50	7.04	4.69	1.50
	0	18.12	4.70	3.86	14.34	4.50	3.19	9.83	4.73	2.08	7.23	4.89	1.48	7.23	4.89	1.48	7.23	4.89	1.48
	2	17.19	4.97	3.46	14.02	4.58	3.06	9.98	4.78	2.09	7.35	4.93	1.49	7.16	4.95	1.45	7.16	4.95	1.45
	5	17.48	5.65	3.09	13.95	5.17	2.70	9.78	6.03	1.62	7.62	6.05	1.26	7.09	6.06	1.17	7.09	6.06	1.17
	7	18.02	6.07	2.97	13.90	6.96	2.00	9.69	7.17	1.35	7.51	7.69	0.98	7.51	7.69	0.98	7.51	7.69	0.98
	10	18.12	7.03	2.58	13.93	8.13	1.71	9.64	8.34	1.16	7.62	8.67	0.88	7.62	8.67	0.88	7.62	8.67	0.88
	12	18.22	7.95	2.29	13.18	9.29	1.42	9.71	9.46	1.03	8.16	9.55	0.85	8.16	9.55	0.85	8.16	9.55	0.85
	15	16.09	8.44	1.91	13.99	9.24	1.51	9.68	9.57	1.01	8.23	9.65	0.85	8.23	9.65	0.85	8.23	9.65	0.85
	20	13.18	10.09	1.31	12.47	10.09	1.24	9.56	10.24	0.93	9.25	10.27	0.90	7.95	10.33	0.77	7.95	10.33	0.77
	25	13.77	11.81	1.17	13.70	11.36	1.21	11.61	11.46	1.01	10.24	11.53	0.89	8.80	11.61	0.76	8.80	11.61	0.76
30	/	/	/	/	/	/	/	/	/	/	/	/	/	/	/	/	/	/	
35	/	/	/	/	/	/	/	/	/	/	/	/	/	/	/	/	/	/	
30	-28	10.97	2.21	4.97	9.12	2.31	3.95	6.22	2.33	2.67	5.45	2.34	2.33	5.32	2.35	2.26	5.32	2.35	2.26
	-20	12.54	2.44	5.14	11.25	2.45	4.59	7.83	2.57	3.05	6.18	2.64	2.34	6.06	2.68	2.26	6.06	2.68	2.26
	-15	14.32	2.68	5.34	12.57	2.49	5.06	9.79	2.65	3.69	7.16	2.82	2.54	7.02	2.83	2.48	7.02	2.83	2.48
	-10	15.98	3.04	5.26	14.10	2.89	4.88	9.64	3.08	3.13	8.43	3.30	2.55	8.13	3.31	2.45	8.13	3.31	2.45
	-7	17.10	3.49	4.90	14.06	3.49	4.03	9.89	3.70	2.67	8.88	3.72	2.39	8.50	3.75	2.27	8.50	3.72	2.28
	-5	17.62	3.75	4.70	14.12	3.58	3.94	9.68	3.71	2.61	9.16	3.72	2.46	9.04	3.78	2.39	9.04	3.76	2.41
	-2	18.50	4.04	4.58	14.20	3.83	3.71	9.81	4.08	2.40	6.94	4.22	1.64	6.50	4.24	1.53	6.50	4.20	1.55
	0	16.94	4.16	4.07	14.16	4.05	3.50	9.60	4.33	2.22	7.11	4.45	1.60	6.86	4.46	1.54	6.86	4.46	1.54
	2	16.86	4.50	3.75	13.13	4.23	3.11	10.08	4.35	2.32	6.88	4.51	1.52	6.65	4.52	1.47	6.65	4.52	1.47
	5	17.10	5.01	3.41	13.16	4.39	2.99	9.95	4.55	2.19	7.28	4.68	1.55	6.77	5.01	1.35	6.77	4.71	1.44
	7	17.67	5.35	3.30	13.53	5.60	2.42	9.85	5.78	1.70	7.23	5.91	1.22	7.19	5.93	1.21	7.19	5.93	1.21
	10	17.71	6.04	2.93	13.53	6.22	2.18	9.57	6.42	1.49	7.46	6.52	1.14	7.38	6.53	1.13	7.32	6.53	1.12
	12	17.87	6.67	2.68	12.80	7.11	1.80	9.40	7.28	1.29	8.04	7.35	1.09	7.95	7.36	1.08	7.89	7.36	1.07
	15	15.76	6.73	2.34	13.92	6.91	2.01	9.69	7.56	1.28	8.21	7.63	1.08	8.12	7.64	1.06	7.92	7.64	1.04
	20	12.81	7.81	1.64	12.12	7.91	1.53	10.18	8.01	1.27	8.97	8.07	1.11	7.91	8.13	0.97	7.70	8.13	0.95
	25	13.45	9.04	1.49	13.35	8.98	1.49	10.45	9.15	1.14	9.98	9.17	1.09	8.87	9.24	0.96	8.57	9.24	0.93
30	14.64	10.29	1.42	14.56	10.24	1.42	10.32	10.44	0.99	10.13	10.46	0.97	9.33	10.51	0.89	9.33	10.51	0.89	
35	/	/	/	/	/	/	/	/	/	/	/	/	/	/	/	/	/	/	
35	-28	10.87	2.01	5.40	6.81	2.15	3.17	5.25	2.18	2.41	5.05	2.21	2.29	4.95	2.23	2.22	4.95	2.23	2.22
	-20	12.44	2.20	5.65	11.27	2.23	5.05	7.87	2.44	3.23	6.15	2.51	2.45	5.61	2.53	2.22	5.61	2.53	2.22
	-15	14.21	2.42	5.87	12.50	2.26	5.53	9.83	2.57	3.83	6.97	2.80	2.49	6.97	2.80	2.49	6.97	2.80	2.49
	-10	15.91	2.76	5.76	14.35	2.75	5.22	9.87	2.92	3.38	8.16	3.01	2.71	8.01	3.02	2.65	8.01	3.02	2.65
	-7	17.11	3.17	5.40	14.00	2.84	4.93	9.99	3.18	3.14	8.51	3.25	2.62	8.41	3.26	2.58	8.41	3.26	2.58
	-5	17.66	3.41	5.18	14.19	3.11	4.56	9.98	3.31	3.01	8.99	3.46	2.60	8.64	3.47	2.49	8.64	3.47	2.49
	-2	18.48	3.67	5.04	14.41	3.24	4.45	9.90	3.46	2.86	6.93	3.61	1.92	6.51	3.63	1.79	6.51	3.63	1.79
	0	18.60	3.89	4.78	14.23	3.32	4.29	9.68	3.55	2.73	7.07	3.68	1.92	6.60	3.71	1.78	6.60	3.71	1.78
	2	18.37	4.14	4.44	14.00	3.51	3.99	9.75	3.72	2.62	6.81	3.87	1.76	6.47	3.89	1.66	6.47	3.89	1.66
	5	18.44	4.53	4.07	14.13	4.15	3.40	9.44	4.41	2.14	7.08	4.67	1.52	6.59	4.88	1.35	6.59	4.88	1.35
	7	18.90	4.78	3.96	14.00	4.84	2.89	9.55	5.12	1.87	7.15	5.24	1.36	7.01	5.26	1.33	7.01	5.26	1.33
	10	17.40	5.25	3.32	13.91	5.28	2.63	9.59	5.57	1.72	7.31	5.63	1.30	7.21	5.64	1.28	7.10	5.64	1.26
	12	17.62	5.77	3.06	14.09	5.78	2.44	9.44	6.15	1.53	7.85	6.24	1.26	7.75	6.25	1.24	7.75	6.25	1.24
	15	15.54	5.76	2.70	14.00	5.81	2.41	9.42	6.40	1.47	7.95	6.48	1.23	7.80	6.49	1.20	7.80	6.49	1.20
	20	12.50	6.45	1.94	12.50	6.45	1.94	9.92	6.71	1.48	8.23	6.79	1.21	7.49	6.82	1.10	7.49	6.82	1.10
	25	13.18	7.21	1.83	13.10	7.36	1.78	9.74	7.53	1.29	9.13	7.56	1.21	8.35	7.61	1.10	8.35	7.61	1.10
30	14.38	8.30	1.73	14.29	8.27	1.73	9.87	8.49	1.16	9.52	8.51	1.12	9.12	8.53	1.07	9.12	8.53	1.07	
35	14.83	9.66	1.54	14.58	9.58	1.52	10.59	9.78	1.08	10.51	9.81	1.07	9.94	9.84	1.01	9.94	9.84	1.01	

LWT	DB	Maximum			100%(Normal)			75%			50%			25%			Minimum		
		HC	COP	PI	HC	COP	PI	HC	COP	PI	HC	COP	PI	HC	COP	PI	HC	COP	PI
40	-28	10.90	1.88	5.80	8.87	1.99	4.46	6.57	2.13	3.09	5.71	2.14	2.67	5.15	2.15	2.40	5.15	2.14	2.41
	-20	12.52	2.05	6.11	10.37	2.15	4.82	7.25	2.31	3.14	6.15	2.37	2.59	6.09	2.38	2.56	6.02	2.38	2.53
	-15	14.32	2.24	6.39	12.73	2.37	5.37	9.08	2.48	3.66	7.11	2.56	2.78	7.05	2.57	2.74	6.98	2.57	2.72
	-10	15.77	2.56	6.16	12.92	2.47	5.23	9.10	2.63	3.47	8.19	2.68	3.06	8.12	2.70	3.01	8.06	2.70	2.99
	-7	17.25	2.89	5.97	13.08	2.83	4.62	9.03	3.05	2.96	8.51	3.07	2.77	8.51	3.07	2.77	8.51	3.07	2.77
	-5	17.16	3.09	5.55	13.03	3.02	4.31	8.99	3.19	2.82	8.88	3.20	2.78	8.75	3.22	2.72	8.75	3.22	2.72
	-2	18.52	3.30	5.61	13.24	3.22	4.12	9.29	3.42	2.72	7.52	3.46	2.17	7.45	3.47	2.15	7.39	3.47	2.13
	0	18.56	3.48	5.33	12.91	3.26	3.96	9.44	3.50	2.70	7.95	3.51	2.26	7.85	3.52	2.23	7.79	3.52	2.21
	2	18.28	3.70	4.94	13.06	3.39	3.85	9.26	3.62	2.55	8.12	3.67	2.21	8.05	3.68	2.19	8.05	3.68	2.19
	5	18.36	4.04	4.54	13.59	4.13	3.29	9.28	4.27	2.17	6.69	4.36	1.53	6.34	4.38	1.45	6.24	4.38	1.42
	7	18.84	4.25	4.43	14.05	4.39	3.20	9.56	4.51	2.12	6.92	4.62	1.50	6.76	4.64	1.46	6.66	4.64	1.44
	10	18.74	4.68	4.00	13.65	4.77	2.86	9.61	4.97	1.93	7.04	5.07	1.39	6.93	5.08	1.36	6.83	5.08	1.34
	12	19.01	5.14	3.70	13.39	5.24	2.56	9.50	5.26	1.81	7.61	5.35	1.42	7.55	5.36	1.41	7.48	5.36	1.40
	15	16.76	5.16	3.25	14.08	5.25	2.68	9.51	5.39	1.77	7.76	5.49	1.41	7.64	5.50	1.39	7.54	5.50	1.37
	20	12.40	5.56	2.23	11.74	5.60	2.09	9.69	5.67	1.71	7.62	5.77	1.32	7.46	5.79	1.29	7.36	5.79	1.27
25	13.00	6.26	2.08	12.92	6.23	2.07	9.52	6.42	1.48	8.43	6.47	1.30	8.33	6.48	1.29	8.23	6.48	1.27	
30	14.21	6.99	2.03	14.12	6.95	2.03	10.14	7.21	1.41	9.52	7.23	1.32	9.12	7.26	1.26	9.02	7.26	1.24	
35	14.63	8.05	1.82	14.38	8.17	1.76	10.35	8.52	1.21	9.66	8.55	1.13	9.55	8.58	1.11	9.55	8.58	1.11	
45	-28	11.05	1.76	6.27	8.71	1.76	4.94	6.57	1.83	3.59	5.62	1.85	3.04	5.62	1.85	3.04	5.62	1.85	3.04
	-20	12.71	1.91	6.66	10.15	1.92	5.29	6.91	2.04	3.39	6.59	2.06	3.20	6.49	2.08	3.12	6.49	2.08	3.12
	-15	14.30	2.09	6.84	11.98	2.11	5.68	8.27	2.30	3.59	7.49	2.32	3.23	7.39	2.33	3.17	7.39	2.33	3.17
	-10	15.28	2.39	6.39	11.88	2.26	5.26	8.75	2.40	3.65	8.62	2.41	3.58	8.52	2.42	3.52	8.52	2.42	3.52
	-7	16.81	2.65	6.34	11.90	2.53	4.70	9.43	2.69	3.51	9.35	2.70	3.46	9.25	2.71	3.41	9.25	2.71	3.41
	-5	15.92	2.80	5.69	12.04	2.75	4.38	10.05	2.82	3.56	9.91	2.83	3.50	9.91	2.83	3.50	9.91	2.83	3.50
	-2	17.23	3.00	5.74	12.24	2.94	4.16	9.62	3.02	3.19	9.52	3.03	3.14	9.42	3.05	3.09	9.42	3.05	3.09
	0	18.18	3.15	5.77	12.40	3.04	4.08	9.87	3.14	3.14	9.77	3.16	3.09	9.77	3.16	3.09	9.77	3.16	3.09
	2	18.25	3.32	5.50	12.10	3.06	3.95	9.95	3.19	3.12	9.85	3.20	3.08	9.85	3.20	3.08	9.85	3.20	3.08
	5	18.31	3.62	5.06	13.09	3.69	3.55	9.13	3.79	2.41	6.99	3.83	1.83	6.91	3.85	1.79	6.91	3.85	1.79
	7	18.79	3.81	4.94	14.00	3.78	3.70	9.68	3.98	2.43	7.48	4.06	1.84	7.48	4.06	1.84	7.48	4.06	1.84
	10	18.67	4.16	4.49	13.68	4.22	3.24	9.52	4.32	2.20	7.19	4.46	1.61	7.13	4.48	1.59	7.13	4.48	1.59
	12	19.05	4.58	4.16	13.38	4.55	2.94	9.70	4.71	2.06	7.95	4.81	1.65	7.89	4.82	1.64	7.89	4.82	1.64
	15	16.87	4.64	3.64	14.14	4.71	3.00	9.75	4.72	2.07	7.97	4.74	1.68	7.46	4.84	1.54	7.46	4.84	1.54
	20	13.31	4.90	2.71	12.46	4.83	2.58	9.46	4.96	1.91	8.28	4.98	1.66	7.84	5.00	1.57	7.84	5.00	1.57
25	13.82	5.42	2.55	13.73	5.35	2.57	9.60	5.44	1.77	9.29	5.46	1.70	8.78	5.48	1.60	8.78	5.48	1.60	
30	15.04	5.99	2.51	13.95	5.94	2.35	10.65	6.08	1.75	10.18	6.10	1.67	9.62	6.11	1.57	9.62	6.11	1.57	
35	15.33	6.80	2.26	15.21	6.76	2.25	10.68	6.98	1.53	10.31	7.05	1.46	10.27	7.08	1.45	10.22	7.08	1.44	
50	-28	/	/	/	/	/	/	/	/	/	/	/	/	/	/	/	/	/	/
	-20	12.14	1.77	6.87	9.57	1.74	5.50	6.91	1.86	3.72	6.61	1.88	3.52	6.56	1.89	3.47	6.56	1.89	3.47
	-15	13.36	1.95	6.85	11.64	1.76	6.63	8.31	1.93	4.30	8.15	1.94	4.20	8.04	1.95	4.12	7.94	1.95	4.07
	-10	13.95	2.17	6.43	11.71	1.82	6.43	9.44	1.94	4.87	9.24	1.99	4.64	9.24	1.99	4.64	9.14	1.99	4.59
	-7	15.50	2.41	6.43	12.13	2.23	5.44	9.83	2.35	4.18	9.76	2.36	4.14	9.76	2.36	4.14	9.66	2.36	4.09
	-5	14.65	2.56	5.72	11.73	2.42	4.85	10.41	2.49	4.18	10.41	2.49	4.18	10.29	2.51	4.10	10.21	2.51	4.07
	-2	15.66	2.75	5.69	12.07	2.58	4.68	10.81	2.65	4.08	10.63	2.66	4.00	10.43	2.67	3.91	10.43	2.67	3.91
	0	16.51	2.88	5.73	12.40	2.67	4.64	11.07	2.77	4.00	10.98	2.78	3.95	10.85	2.89	3.75	10.85	2.89	3.75
	2	17.36	3.01	5.77	12.17	2.75	4.43	11.26	2.80	4.02	11.05	2.82	3.92	11.05	2.82	3.92	11.05	2.82	3.92
	5	18.26	3.25	5.62	13.11	3.31	3.96	9.73	3.45	2.82	9.63	3.47	2.78	8.67	3.48	2.49	8.57	3.48	2.46
	7	18.72	3.41	5.49	13.81	3.53	3.91	9.50	3.70	2.57	9.24	3.72	2.48	9.16	3.73	2.46	9.16	3.73	2.46
	10	18.59	3.72	5.00	13.70	3.72	3.68	9.66	3.92	2.46	7.38	3.96	1.86	7.29	4.03	1.81	7.23	4.03	1.79
	12	17.80	4.15	4.29	13.45	4.02	3.34	9.47	4.09	2.31	8.13	4.12	1.97	8.05	4.13	1.95	8.00	4.13	1.94
	15	16.93	4.15	4.08	14.16	4.19	3.38	9.89	4.25	2.33	8.25	4.26	1.94	8.18	4.27	1.92	8.08	4.27	1.89
	20	13.24	4.33	3.06	12.42	4.18	2.97	9.52	4.30	2.21	8.11	4.32	1.88	8.11	4.32	1.88	8.11	4.32	1.88
25	13.67	4.73	2.89	13.57	4.59	2.96	10.30	4.71	2.19	9.17	4.74	1.93	9.01	4.75	1.90	8.94	4.75	1.88	
30	14.87	5.23	2.84	14.30	5.16	2.77	10.31	5.26	1.96	10.15	5.29	1.92	9.89	5.32	1.86	9.81	5.32	1.84	
35	15.15	5.96	2.54	14.03	5.88	2.39	11.53	6.01	1.92	10.99	6.04	1.82	10.92	6.06	1.80	10.92	6.06	1.80	

LWT	DB	Maximum			100%(Normal)			75%			50%			25%			Minimum		
		HC	COP	PI	HC	COP	PI	HC	COP	PI	HC	COP	PI	HC	COP	PI	HC	COP	PI
55	-28	/	/	/	/	/	/	/	/	/	/	/	/	/	/	/	/	/	/
	-20	11.12	1.61	6.90	9.50	1.63	5.82	8.61	1.66	5.18	7.59	1.69	4.48	6.11	1.60	3.82	6.11	1.60	3.82
	-15	12.31	1.79	6.87	11.23	1.81	6.22	10.78	1.82	5.92	8.78	1.89	4.64	6.24	1.67	3.74	6.24	1.67	3.74
	-10	12.85	2.01	6.39	11.97	1.88	6.36	10.54	1.94	5.44	9.24	1.98	4.66	6.31	1.83	3.45	6.31	1.83	3.45
	-7	14.31	2.26	6.33	11.90	2.12	5.61	10.77	2.21	4.87	10.69	2.22	4.82	10.61	2.22	4.78	10.61	2.22	4.78
	-5	13.81	2.41	5.73	12.12	2.23	5.44	11.27	2.26	4.99	11.17	2.27	4.92	11.17	2.27	4.92	11.17	2.27	4.92
	-2	14.93	2.59	5.76	12.27	2.38	5.16	11.26	2.43	4.63	11.10	2.44	4.55	11.00	2.45	4.49	11.00	2.45	4.49
	0	15.73	2.72	5.78	12.18	2.50	4.87	11.51	2.58	4.46	11.43	2.59	4.41	11.43	2.59	4.41	11.43	2.59	4.41
	2	16.31	2.85	5.72	12.30	2.55	4.82	11.84	2.61	4.54	11.63	2.63	4.42	11.63	2.63	4.42	11.63	2.63	4.42
	5	17.56	3.04	5.78	13.05	2.82	4.63	10.56	2.88	3.67	9.94	3.05	3.26	9.94	3.05	3.26	9.94	3.05	3.26
	7	18.46	3.19	5.78	14.00	3.00	4.67	9.99	3.18	3.14	9.51	3.19	2.98	9.51	3.19	2.98	9.51	3.19	2.98
	10	18.82	3.45	5.46	13.88	3.41	4.07	9.55	3.42	2.79	9.15	3.46	2.64	9.15	3.46	2.64	9.15	3.46	2.64
	12	17.10	3.85	4.44	13.49	3.65	3.70	10.13	3.71	2.73	10.13	3.71	2.73	10.13	3.71	2.73	10.13	3.71	2.73
	15	16.89	3.83	4.41	13.93	3.84	3.63	10.17	3.74	2.72	10.17	3.74	2.72	10.17	3.74	2.72	10.17	3.74	2.72
	20	13.30	3.92	3.40	12.38	3.79	3.27	9.36	3.81	2.46	8.37	3.86	2.17	8.17	3.88	2.11	8.17	3.88	2.11
25	13.68	4.28	3.19	13.61	4.29	3.17	10.11	4.31	2.35	9.62	4.35	2.21	9.40	4.50	2.09	9.40	4.50	2.09	
30	14.87	4.75	3.13	14.78	4.61	3.21	10.58	4.71	2.25	10.51	4.72	2.23	10.32	4.73	2.18	10.32	4.73	2.18	
35	15.10	5.46	2.77	15.04	5.37	2.80	12.16	5.55	2.19	11.95	5.59	2.14	11.29	5.61	2.01	11.29	5.61	2.01	
60	-28	/	/	/	/	/	/	/	/	/	/	/	/	/	/	/	/	/	/
	-20	/	/	/	/	/	/	/	/	/	/	/	/	/	/	/	/	/	/
	-15	11.13	1.64	6.77	8.13	1.30	6.25	6.45	1.32	4.89	6.25	1.34	4.66	6.15	1.36	4.52	6.05	1.36	4.45
	-10	11.91	1.87	6.37	8.25	1.32	6.25	6.65	1.34	4.96	6.55	1.36	4.82	6.35	1.38	4.60	6.35	1.38	4.60
	-7	13.48	2.10	6.42	11.35	1.91	5.94	10.69	2.01	5.32	10.48	2.02	5.19	10.38	2.05	5.06	10.38	2.05	5.06
	-5	12.73	2.25	5.66	11.26	2.01	5.60	11.12	2.04	5.45	11.02	2.06	5.35	10.92	2.07	5.28	10.92	2.07	5.28
	-2	13.75	2.41	5.71	12.18	2.26	5.40	10.65	2.30	4.64	10.48	2.31	4.54	10.48	2.31	4.54	10.48	2.31	4.54
	0	14.47	2.52	5.74	11.98	2.29	5.23	11.02	2.34	4.71	10.92	2.35	4.65	10.82	2.35	4.60	10.82	2.35	4.60
	2	14.89	2.60	5.73	12.03	2.31	5.21	11.16	2.36	4.73	11.10	2.37	4.68	11.10	2.37	4.68	11.01	2.37	4.65
	5	15.72	2.77	5.67	13.18	2.44	5.40	10.40	2.63	3.95	10.40	2.63	3.95	10.24	2.65	3.86	10.24	2.65	3.86
	7	16.79	2.90	5.78	13.86	2.94	4.72	10.95	3.04	3.60	10.79	3.06	3.53	10.79	3.06	3.53	10.79	3.06	3.53
	10	17.75	3.10	5.73	13.94	3.16	4.41	10.52	3.22	3.27	10.42	3.23	3.23	10.22	3.30	3.10	10.12	3.30	3.07
	12	14.77	3.39	4.36	12.97	3.33	3.90	11.42	3.37	3.39	10.27	3.39	3.03	10.07	3.42	2.94	10.07	3.42	2.94
	15	15.08	3.41	4.43	13.88	3.41	4.07	10.56	3.42	3.09	10.38	3.43	3.03	10.28	3.44	2.99	10.28	3.44	2.99
	20	11.75	3.36	3.50	11.75	3.46	3.40	10.16	3.52	2.89	8.83	3.58	2.47	8.54	3.60	2.37	8.44	3.60	2.34
25	12.95	3.77	3.44	12.95	3.72	3.48	9.79	3.85	2.54	9.79	3.85	2.54	9.46	3.88	2.44	9.46	3.88	2.44	
30	14.06	4.19	3.35	14.06	4.19	3.35	10.13	4.35	2.33	9.96	4.36	2.28	9.67	4.37	2.21	9.67	4.37	2.21	
35	/	/	/	/	/	/	/	/	/	/	/	/	/	/	/	/	/	/	/
65	-28	/	/	/	/	/	/	/	/	/	/	/	/	/	/	/	/	/	/
	-20	/	/	/	/	/	/	/	/	/	/	/	/	/	/	/	/	/	/
	-15	/	/	/	/	/	/	/	/	/	/	/	/	/	/	/	/	/	/
	-10	/	/	/	/	/	/	/	/	/	/	/	/	/	/	/	/	/	/
	-7	/	/	/	/	/	/	/	/	/	/	/	/	/	/	/	/	/	/
	-5	/	/	/	/	/	/	/	/	/	/	/	/	/	/	/	/	/	/
	-2	/	/	/	/	/	/	/	/	/	/	/	/	/	/	/	/	/	/
	0	/	/	/	/	/	/	/	/	/	/	/	/	/	/	/	/	/	/
	2	/	/	/	/	/	/	/	/	/	/	/	/	/	/	/	/	/	/
	5	14.47	2.50	5.78	12.80	2.35	5.45	9.28	2.52	3.68	9.21	2.53	3.64	9.21	2.53	3.64	9.21	2.53	3.64
	7	14.78	2.50	5.91	13.13	2.50	5.25	9.81	2.61	3.76	9.81	2.61	3.76	9.69	2.63	3.68	9.69	2.63	3.68
	10	15.87	2.77	5.74	12.45	2.76	4.51	9.66	2.83	3.41	9.43	2.87	3.29	9.33	2.88	3.24	9.33	2.88	3.24
	12	12.72	2.91	4.37	11.48	2.87	4.00	10.21	2.90	3.52	10.21	2.90	3.52	9.99	2.93	3.41	9.99	2.93	3.41
	15	12.76	2.93	4.35	12.76	2.93	4.35	9.25	2.93	3.16	9.01	2.97	3.03	9.01	2.97	3.03	9.01	2.97	3.03
	20	/	/	/	/	/	/	/	/	/	/	/	/	/	/	/	/	/	/
25	/	/	/	/	/	/	/	/	/	/	/	/	/	/	/	/	/	/	/
30	/	/	/	/	/	/	/	/	/	/	/	/	/	/	/	/	/	/	/
35	/	/	/	/	/	/	/	/	/	/	/	/	/	/	/	/	/	/	/

Abbreviations:

LWT: Leaving water temperature (°C)

DB: Dry-bulb temperature for Outdoor air temperature (°C)

HC: Total heating capacity (kW)

PI: Power input (kW)

16kW model heating capacity

LWT	DB	Maximum			100%(Normal)			75%			50%			25%			Minimum		
		HC	COP	PI	HC	COP	PI	HC	COP	PI	HC	COP	PI	HC	COP	PI	HC	COP	PI
25	-28	10.10	2.27	4.46	9.74	2.00	4.87	6.48	2.35	2.76	6.02	2.39	2.52	4.93	2.44	2.02	4.93	2.44	2.02
	-20	11.76	2.50	4.71	11.76	2.50	4.71	8.72	2.65	3.29	6.26	2.77	2.26	5.41	2.81	1.93	5.41	2.81	1.93
	-15	13.67	2.77	4.93	13.40	2.51	5.34	11.00	2.72	4.04	7.82	2.81	2.78	7.32	2.84	2.58	7.32	2.84	2.58
	-10	15.54	3.17	4.91	14.74	2.97	4.97	10.75	3.17	3.39	7.67	3.35	2.29	7.67	3.35	2.29	7.67	3.35	2.29
	-7	16.83	3.58	4.70	14.97	3.44	4.35	10.88	3.64	2.99	8.79	3.93	2.24	8.79	3.93	2.24	8.79	3.93	2.24
	-5	17.25	3.77	4.58	15.57	3.63	4.28	10.79	3.88	2.78	9.46	4.12	2.29	9.25	4.14	2.23	9.25	4.14	2.23
	-2	18.12	4.14	4.38	15.52	3.86	4.02	10.67	4.15	2.57	7.83	4.65	1.68	7.14	4.68	1.53	7.14	4.68	1.53
	0	18.58	4.42	4.21	15.62	3.99	3.91	10.92	4.29	2.55	7.68	4.86	1.58	7.23	4.89	1.48	7.23	4.89	1.48
	2	19.20	4.72	4.07	15.61	4.04	3.86	10.68	4.32	2.47	7.79	4.89	1.59	7.29	4.91	1.49	7.29	4.91	1.49
	5	19.12	5.38	3.56	15.84	4.64	3.41	10.88	6.01	1.81	7.85	6.03	1.30	7.19	6.05	1.19	7.19	6.05	1.19
	7	18.94	5.92	3.20	15.47	6.59	2.35	10.75	7.16	1.50	7.81	7.27	1.07	7.65	7.27	1.05	7.65	7.27	1.05
	10	19.49	6.67	2.92	15.80	7.58	2.08	10.86	8.30	1.31	7.75	8.38	0.92	7.75	8.38	0.92	7.75	8.38	0.92
	12	19.24	7.59	2.53	15.07	8.89	1.70	10.67	9.24	1.16	8.39	9.27	0.91	8.26	9.29	0.89	8.26	9.29	0.89
	15	17.19	7.97	2.16	15.71	8.53	1.84	11.01	9.48	1.16	8.48	9.51	0.89	8.39	9.53	0.88	8.39	9.53	0.88
	20	13.50	10.08	1.34	13.50	9.12	1.48	10.81	10.15	1.07	9.35	10.21	0.92	8.19	10.26	0.80	8.19	10.26	0.80
	25	14.84	11.75	1.26	14.84	10.25	1.45	11.71	11.43	1.02	10.33	11.48	0.90	8.92	11.55	0.77	8.92	11.55	0.77
30	/	/	/	/	/	/	/	/	/	/	/	/	/	/	/	/	/	/	/
35	/	/	/	/	/	/	/	/	/	/	/	/	/	/	/	/	/	/	/
30	-28	11.94	2.15	5.56	9.49	2.28	4.16	6.32	2.31	2.74	5.66	2.32	2.44	5.46	2.33	2.34	5.46	2.33	2.34
	-20	13.61	2.35	5.78	12.58	2.40	5.24	8.70	2.53	3.44	6.23	2.63	2.37	6.13	2.66	2.30	6.13	2.66	2.30
	-15	15.42	2.52	6.12	14.15	2.41	5.87	11.03	2.61	4.23	7.88	2.79	2.82	7.72	2.82	2.74	7.72	2.82	2.74
	-10	17.28	2.82	6.13	15.50	2.43	6.38	10.75	3.02	3.56	8.88	3.16	2.81	8.71	3.22	2.70	8.71	3.22	2.70
	-7	18.48	3.16	5.85	15.56	3.33	4.67	10.79	3.61	2.99	9.19	3.65	2.52	8.92	3.67	2.43	8.92	3.67	2.43
	-5	18.93	3.43	5.52	15.55	3.38	4.60	10.85	3.66	2.97	9.30	3.69	2.52	9.14	3.70	2.47	9.14	3.70	2.47
	-2	19.80	3.85	5.14	15.64	3.42	4.57	10.78	3.76	2.87	7.89	3.91	2.02	7.55	3.98	1.90	6.55	3.98	1.65
	0	18.36	4.05	4.53	15.35	3.45	4.45	10.67	4.20	2.54	7.74	4.36	1.78	7.15	4.42	1.62	7.15	4.42	1.62
	2	18.97	4.31	4.41	15.43	3.69	4.18	10.96	4.31	2.54	7.87	4.45	1.77	6.75	4.51	1.50	6.75	4.51	1.50
	5	18.82	4.84	3.89	15.75	4.08	3.86	10.76	4.42	2.43	7.75	4.55	1.71	7.15	4.60	1.55	6.81	4.60	1.48
	7	18.58	5.25	3.54	15.42	5.54	2.78	10.63	5.76	1.85	7.73	5.88	1.32	7.32	5.92	1.24	7.22	5.92	1.22
	10	19.12	5.82	3.29	15.40	6.15	2.50	10.76	6.38	1.69	7.63	6.50	1.17	7.46	6.51	1.15	7.36	6.51	1.13
	12	18.91	6.53	2.89	14.72	6.83	2.16	10.69	7.12	1.50	8.11	7.34	1.11	8.05	7.35	1.10	7.99	7.35	1.09
	15	16.89	6.63	2.55	15.68	6.71	2.34	10.98	7.37	1.49	8.30	7.62	1.09	8.22	7.63	1.08	8.12	7.63	1.06
	20	13.13	7.71	1.70	13.13	7.61	1.73	10.82	7.99	1.35	9.22	8.05	1.15	8.13	8.10	1.00	8.13	8.10	1.00
	25	14.46	8.83	1.64	14.46	8.83	1.64	10.96	8.95	1.22	10.10	9.16	1.10	9.11	9.22	0.99	8.77	9.22	0.95
30	15.78	10.07	1.57	15.78	10.07	1.57	11.12	10.41	1.07	10.23	10.45	0.98	9.45	10.48	0.90	9.35	10.48	0.89	
35	/	/	/	/	/	/	/	/	/	/	/	/	/	/	/	/	/	/	/
35	-28	11.85	1.97	6.01	7.52	2.12	3.55	5.37	2.17	2.47	5.15	2.19	2.35	5.15	2.19	2.35	5.15	2.19	2.35
	-20	13.53	2.14	6.33	12.56	2.14	5.86	8.74	2.36	3.71	6.25	2.50	2.50	5.97	2.52	2.37	5.97	2.52	2.37
	-15	15.41	2.32	6.64	14.15	2.15	6.58	10.96	2.50	4.39	7.78	2.71	2.87	7.03	2.80	2.51	7.03	2.80	2.51
	-10	17.01	2.55	6.66	15.50	2.43	6.38	10.64	2.89	3.68	8.26	2.99	2.76	8.11	3.01	2.69	8.11	3.01	2.69
	-7	18.27	2.81	6.51	15.50	2.68	5.78	10.81	3.17	3.41	8.61	3.23	2.67	8.51	3.24	2.63	8.51	3.24	2.63
	-5	18.53	3.13	5.93	15.50	2.81	5.52	10.96	3.26	3.36	9.15	3.39	2.70	8.94	3.40	2.63	8.94	3.40	2.63
	-2	19.79	3.48	5.68	15.50	2.99	5.18	10.90	3.41	3.20	8.00	3.57	2.24	6.59	3.60	1.83	6.59	3.60	1.83
	0	20.31	3.78	5.37	15.50	3.12	4.97	10.88	3.50	3.11	7.96	3.65	2.18	6.73	3.68	1.83	6.63	3.68	1.80
	2	20.81	3.98	5.24	15.50	3.25	4.77	10.93	3.65	3.00	7.63	3.84	1.99	6.57	3.88	1.69	6.47	3.88	1.67
	5	20.34	4.40	4.62	15.50	4.06	3.82	10.76	4.39	2.45	7.69	4.43	1.74	6.68	4.47	1.49	6.58	4.47	1.47
	7	19.97	4.73	4.22	15.50	4.61	3.36	10.87	4.93	2.20	7.66	5.21	1.47	7.01	5.26	1.33	6.90	5.26	1.31
	10	18.79	5.09	3.69	15.51	5.29	2.93	10.75	5.55	1.94	7.62	5.61	1.36	7.35	5.63	1.31	7.35	5.63	1.31
	12	18.64	5.66	3.29	15.50	5.79	2.68	10.72	6.10	1.76	7.92	6.23	1.27	7.85	6.24	1.26	7.75	6.24	1.24
	15	16.69	5.71	2.92	15.45	5.75	2.69	11.03	6.35	1.74	8.05	6.47	1.24	7.90	6.48	1.22	7.80	6.48	1.20
	20	12.90	6.42	2.01	12.82	6.40	2.00	10.96	6.65	1.65	8.31	6.78	1.23	7.61	6.81	1.12	7.51	6.81	1.10
	25	14.24	7.25	1.96	14.24	7.26	1.96	11.07	7.48	1.48	9.35	7.55	1.24	8.45	7.60	1.11	8.45	7.60	1.11
30	15.52	8.15	1.91	15.52	8.15	1.91	10.98	8.44	1.30	9.92	8.49	1.17	9.12	8.53	1.07	9.12	8.53	1.07	
35	16.52	9.40	1.76	15.58	9.53	1.63	10.79	9.71	1.11	10.62	9.80	1.08	10.04	9.81	1.02	10.04	9.81	1.02	

LWT	DB	Maximum			100%(Normal)			75%			50%			25%			Minimum		
		HC	COP	PI	HC	COP	PI	HC	COP	PI	HC	COP	PI	HC	COP	PI	HC	COP	PI
40	-28	11.89	1.85	6.41	10.08	1.98	5.09	6.88	2.11	3.26	5.81	2.12	2.74	5.21	2.13	2.45	5.21	2.13	2.45
	-20	13.59	2.00	6.78	12.10	2.08	5.80	8.34	2.22	3.76	6.22	2.34	2.66	6.17	2.35	2.63	6.07	2.35	2.58
	-15	15.39	2.17	7.08	14.15	2.16	6.55	10.37	2.46	4.21	7.44	2.55	2.92	7.12	2.56	2.78	7.02	2.56	2.74
	-10	16.34	2.47	6.62	14.57	2.25	6.48	10.29	2.60	3.95	8.34	2.66	3.14	8.22	2.69	3.06	8.10	2.69	3.01
	-7	18.04	2.75	6.55	14.51	2.45	5.92	10.37	2.85	3.64	8.65	2.87	3.01	8.59	2.88	2.98	8.59	2.88	2.98
	-5	17.91	3.06	5.86	14.64	2.51	5.83	10.36	3.08	3.36	9.11	3.09	2.95	9.01	3.10	2.90	9.01	3.10	2.90
	-2	19.06	3.27	5.83	14.54	2.55	5.70	10.29	3.33	3.09	7.66	3.45	2.22	7.55	3.46	2.18	7.45	3.46	2.15
	0	20.31	3.39	5.98	14.65	2.61	5.61	10.47	3.46	3.03	8.07	3.50	2.31	7.91	3.51	2.25	7.81	3.51	2.23
	2	20.80	3.57	5.82	14.84	3.20	4.64	10.33	3.57	2.90	8.22	3.66	2.24	8.13	3.67	2.22	8.09	3.67	2.20
	5	20.22	3.90	5.18	14.40	3.45	4.17	10.76	3.61	2.98	7.42	3.81	1.95	6.62	3.83	1.73	6.62	3.83	1.73
	7	19.84	4.19	4.73	15.47	4.36	3.55	10.76	4.48	2.40	7.64	4.61	1.66	6.84	4.63	1.48	6.74	4.63	1.46
	10	20.28	4.54	4.46	15.57	4.74	3.28	11.41	4.81	2.37	7.61	5.01	1.52	7.01	5.05	1.39	6.90	5.05	1.37
	12	20.13	5.05	3.99	15.59	5.19	3.00	11.12	5.24	2.12	7.75	5.31	1.46	7.61	5.34	1.43	7.51	5.34	1.41
	15	18.00	5.09	3.54	15.41	5.23	2.95	10.53	5.30	1.99	7.91	5.48	1.44	7.78	5.49	1.42	7.58	5.49	1.38
	20	12.74	5.53	2.30	12.74	5.27	2.42	10.74	5.66	1.90	7.73	5.76	1.34	7.59	5.78	1.31	7.39	5.78	1.28
	25	14.08	6.19	2.27	14.08	6.19	2.27	10.84	6.38	1.70	8.55	6.46	1.32	8.46	6.47	1.31	8.26	6.47	1.28
30	15.37	6.90	2.23	15.37	6.90	2.23	10.76	7.19	1.50	9.95	7.22	1.38	9.23	7.24	1.27	9.03	7.24	1.25	
35	16.34	7.87	2.08	15.38	7.92	1.94	10.98	8.50	1.29	9.85	8.53	1.15	9.79	8.57	1.14	9.79	8.57	1.14	
45	-28	12.04	1.77	6.81	11.97	1.61	7.43	6.64	1.81	3.67	5.84	1.84	3.17	5.70	1.86	3.06	5.65	1.86	3.04
	-20	13.32	1.88	7.07	12.16	1.64	7.43	7.83	1.90	4.12	6.68	2.03	3.29	6.55	2.04	3.21	6.55	2.04	3.21
	-15	14.64	2.07	7.07	12.56	2.07	6.07	9.66	2.22	4.34	7.59	2.28	3.33	7.59	2.28	3.33	7.59	2.28	3.33
	-10	15.74	2.36	6.67	13.97	2.09	6.68	9.66	2.36	4.10	8.75	2.40	3.65	8.75	2.40	3.65	8.75	2.40	3.65
	-7	17.33	2.63	6.59	13.70	2.44	5.61	9.71	2.64	3.68	9.49	2.66	3.57	9.25	2.71	3.41	9.25	2.71	3.41
	-5	16.48	2.79	5.90	13.84	2.49	5.56	10.21	2.80	3.65	10.01	2.82	3.55	9.91	2.83	3.50	9.88	2.83	3.49
	-2	17.82	2.99	5.97	13.91	2.53	5.50	9.75	3.01	3.24	9.65	3.02	3.20	9.42	3.05	3.09	9.35	3.03	3.09
	0	18.60	3.13	5.94	13.95	2.59	5.39	9.97	3.13	3.19	9.91	3.14	3.16	9.77	3.16	3.09	9.73	3.15	3.09
	2	19.12	3.28	5.83	14.00	2.90	4.83	10.05	3.18	3.16	9.90	3.19	3.10	9.85	3.20	3.08	9.79	3.20	3.06
	5	20.17	3.52	5.73	14.90	3.37	4.42	10.39	3.51	2.96	7.16	3.82	1.87	6.91	3.85	1.79	6.91	3.84	1.80
	7	19.76	3.73	5.29	15.50	3.69	4.20	10.99	3.85	2.86	7.65	4.02	1.90	7.48	4.06	1.84	7.39	4.04	1.83
	10	20.19	4.05	4.99	16.25	4.19	3.88	10.92	4.30	2.54	7.84	4.42	1.77	7.13	4.48	1.59	7.11	4.45	1.60
	12	20.15	4.50	4.48	15.70	4.49	3.50	10.83	4.55	2.38	8.05	4.71	1.71	7.89	4.82	1.64	7.81	4.81	1.62
	15	18.10	4.57	3.96	15.52	4.68	3.32	10.89	4.69	2.32	8.11	4.73	1.71	7.95	4.82	1.65	7.95	4.82	1.65
	20	13.70	4.90	2.79	13.70	4.81	2.85	10.96	4.95	2.21	8.45	4.96	1.70	8.15	4.99	1.63	8.15	4.99	1.63
	25	15.05	5.40	2.79	15.05	5.30	2.84	10.97	5.38	2.04	9.45	5.45	1.73	9.05	5.47	1.65	8.69	5.47	1.59
30	16.38	5.96	2.75	16.38	5.83	2.81	11.13	6.06	1.84	10.26	6.09	1.68	9.68	6.10	1.59	9.68	6.10	1.59	
35	16.20	6.72	2.41	16.20	6.72	2.41	10.76	6.96	1.55	10.45	7.02	1.49	10.35	7.03	1.47	10.28	7.03	1.46	
50	-28	/	/	/	/	/	/	/	/	/	/	/	/	/	/	/	/	/	/
	-20	12.75	1.52	8.40	10.19	1.58	6.45	7.85	1.65	4.76	6.95	1.71	4.06	6.95	1.71	4.06	6.95	1.71	4.06
	-15	13.62	1.94	7.03	12.13	1.75	6.93	9.67	1.86	5.20	8.31	1.89	4.40	8.19	1.91	4.29	8.19	1.92	4.27
	-10	14.43	2.16	6.68	12.19	1.79	6.81	9.82	1.91	5.14	9.34	1.94	4.81	9.34	1.94	4.81	9.34	1.94	4.81
	-7	16.05	2.40	6.69	13.49	2.08	6.47	9.91	2.26	4.38	9.91	2.26	4.38	9.91	2.26	4.38	9.91	2.26	4.38
	-5	15.18	2.53	6.00	12.92	2.19	5.89	11.41	2.32	4.92	10.60	2.33	4.55	10.42	2.34	4.45	10.42	2.34	4.45
	-2	16.04	2.73	5.88	13.57	2.34	5.81	10.89	2.48	4.39	10.72	2.49	4.31	10.53	2.50	4.21	10.53	2.50	4.21
	0	17.11	2.85	6.00	13.66	2.41	5.66	11.25	2.53	4.45	11.05	2.55	4.33	10.99	2.56	4.29	10.99	2.56	4.29
	2	17.78	2.99	5.95	13.75	2.43	5.65	11.31	2.55	4.44	11.19	2.60	4.30	11.11	2.62	4.24	11.11	2.62	4.24
	5	18.72	3.22	5.82	13.66	3.09	4.42	10.65	3.11	3.43	9.79	3.14	3.12	9.15	3.16	2.90	9.15	3.16	2.90
	7	19.69	3.36	5.85	15.44	3.50	4.41	10.90	3.65	2.99	9.35	3.70	2.53	9.21	3.72	2.48	9.21	3.72	2.48
	10	20.10	3.63	5.54	15.52	3.69	4.21	10.74	3.86	2.78	7.82	3.93	1.99	7.35	4.01	1.83	7.35	4.01	1.83
	12	18.94	4.08	4.64	15.78	3.95	4.00	11.03	4.06	2.72	8.25	4.10	2.01	8.15	4.11	1.98	8.15	4.11	1.98
	15	18.15	4.08	4.45	15.60	4.18	3.73	10.70	4.13	2.59	8.32	4.21	1.98	8.23	4.25	1.94	8.23	4.25	1.94
	20	13.65	4.32	3.16	13.65	4.12	3.31	10.76	4.26	2.53	8.25	4.29	1.92	8.17	4.30	1.90	8.17	4.30	1.90
	25	14.98	4.74	3.16	14.98	4.54	3.30	10.68	4.68	2.28	9.29	4.72	1.97	9.11	4.74	1.92	9.11	4.74	1.92
30	16.28	5.22	3.12	15.69	5.11	3.07	11.26	5.25	2.14	10.88	5.27	2.06	9.89	5.32	1.86	9.89	5.32	1.86	
35	17.15	5.84	2.94	16.03	5.86	2.73	11.72	5.99	1.96	11.11	6.02	1.85	11.05	6.04	1.83	11.05	6.04	1.83	

LWT	DB	Maximum			100%(Normal)			75%			50%			25%			Minimum			
		HC	COP	PI	HC	COP	PI	HC	COP	PI	HC	COP	PI	HC	COP	PI	HC	COP	PI	
55	-28	/	/	/	/	/	/	/	/	/	/	/	/	/	/	/	/	/	/	
	-20	11.72	1.42	8.28	10.14	1.56	6.50	7.11	1.56	4.56	6.93	1.57	4.41	6.43	1.59	4.04	6.43	1.59	4.04	
	-15	12.76	1.79	7.13	11.73	1.71	6.86	7.21	1.58	4.56	7.01	1.65	4.25	6.71	1.66	4.04	6.71	1.66	4.04	
	-10	13.34	2.00	6.67	12.33	1.86	6.63	10.11	1.74	5.81	7.11	1.78	3.99	6.81	1.82	3.74	6.81	1.82	3.74	
	-7	14.65	2.24	6.55	13.70	2.12	6.46	10.91	2.20	4.96	10.83	2.21	4.90	10.61	2.22	4.78	10.61	2.22	4.78	
	-5	14.19	2.40	5.91	13.70	2.18	6.28	11.35	2.25	5.04	11.29	2.26	5.00	11.17	2.27	4.92	11.17	2.27	4.92	
	-2	15.32	2.58	5.95	13.76	2.26	6.09	11.38	2.42	4.70	11.31	2.43	4.65	11.10	2.44	4.55	11.10	2.44	4.55	
	0	16.14	2.70	5.97	13.78	2.32	5.94	11.62	2.48	4.69	11.53	2.49	4.63	11.53	2.49	4.63	11.53	2.49	4.63	
	2	16.73	2.83	5.91	13.80	2.38	5.80	11.92	2.51	4.75	11.79	2.52	4.68	11.73	2.53	4.64	11.73	2.53	4.64	
	5	18.01	3.04	5.93	14.82	2.75	5.39	11.34	2.86	3.97	10.11	2.96	3.42	10.11	2.96	3.42	10.11	2.96	3.42	
	7	19.11	3.16	6.05	15.50	2.99	5.18	10.93	3.11	3.52	10.65	3.12	3.41	10.65	3.12	3.41	10.65	3.12	3.41	
	10	20.33	3.38	6.02	16.41	3.30	4.97	10.70	3.37	3.17	9.36	3.45	2.71	9.36	3.45	2.71	9.36	3.45	2.71	
	12	17.64	3.81	4.63	16.03	3.55	4.52	10.98	3.68	2.98	10.25	3.69	2.78	10.19	3.70	2.75	10.19	3.70	2.75	
	15	17.20	3.81	4.51	15.56	3.88	4.01	11.05	3.72	2.97	10.26	3.73	2.75	10.26	3.73	2.75	10.26	3.73	2.75	
	20	13.74	3.93	3.50	13.74	3.66	3.75	10.67	3.78	2.82	8.44	3.85	2.19	8.37	3.87	2.16	8.37	3.87	2.16	
25	15.07	4.31	3.50	15.07	4.06	3.71	10.51	4.14	2.54	9.75	4.34	2.25	9.51	4.35	2.19	9.51	4.35	2.19		
30	16.36	4.74	3.45	16.36	4.57	3.58	10.68	4.70	2.27	10.64	4.71	2.26	10.42	4.72	2.21	10.42	4.72	2.21		
35	17.20	5.33	3.23	17.20	5.33	3.23	12.25	5.54	2.21	12.01	5.58	2.15	11.39	5.60	2.03	11.39	5.60	2.03		
60	-28	/	/	/	/	/	/	/	/	/	/	/	/	/	/	/	/	/	/	
	-20	/	/	/	/	/	/	/	/	/	/	/	/	/	/	/	/	/	/	
	-15	11.57	1.64	7.07	10.06	1.22	8.25	6.69	1.24	5.40	6.69	1.24	5.40	6.69	1.24	5.40	6.69	1.24	5.40	
	-10	12.37	1.85	6.68	9.99	1.26	7.93	6.75	1.28	5.27	6.75	1.28	5.27	6.75	1.28	5.27	6.75	1.28	5.27	
	-7	13.82	2.09	6.61	12.11	1.75	6.93	10.81	1.82	5.94	10.62	1.83	5.80	10.51	1.84	5.71	10.51	1.84	5.71	
	-5	13.28	2.22	5.98	12.20	1.88	6.50	11.22	1.93	5.81	11.15	1.94	5.75	11.05	1.95	5.67	11.05	1.95	5.67	
	-2	14.34	2.90	4.94	12.86	2.02	6.36	10.82	2.12	5.10	10.68	2.14	4.99	10.58	2.15	4.92	10.58	2.15	4.92	
	0	14.88	2.50	5.95	13.35	2.09	6.38	11.12	2.15	5.17	11.02	2.16	5.10	10.92	2.16	5.06	10.92	2.16	5.06	
	2	15.11	2.59	5.84	14.41	2.15	6.71	11.28	2.21	5.10	11.19	2.22	5.04	11.19	2.22	5.04	11.19	2.22	5.04	
	5	16.23	2.76	5.88	15.51	2.16	7.17	10.88	2.32	4.69	10.69	2.34	4.57	10.59	2.35	4.51	10.59	2.35	4.51	
	7	17.04	2.89	5.89	15.15	2.71	5.58	11.02	2.91	3.79	10.85	2.92	3.72	10.85	2.92	3.72	10.85	2.92	3.72	
	10	18.52	3.07	6.02	15.84	3.10	5.10	10.85	3.21	3.38	10.75	3.22	3.34	10.55	3.29	3.21	10.55	3.29	3.21	
	12	15.43	3.38	4.56	14.00	3.30	4.25	11.56	3.36	3.44	11.32	3.37	3.36	11.27	3.38	3.33	11.27	3.38	3.33	
	15	15.40	3.39	4.54	15.40	3.39	4.54	11.31	3.40	3.33	11.21	3.41	3.29	11.11	3.43	3.24	11.11	3.43	3.24	
	20	13.06	3.40	3.84	13.06	3.40	3.84	11.06	3.50	3.16	8.92	3.57	2.50	8.71	3.59	2.43	8.71	3.59	2.43	
25	14.35	3.77	3.80	14.35	3.77	3.81	11.15	3.74	2.98	9.95	3.81	2.61	9.79	3.83	2.56	9.79	3.83	2.56		
30	15.54	4.15	3.74	15.54	4.15	3.74	10.74	4.33	2.48	10.59	4.34	2.44	10.37	4.36	2.38	10.37	4.36	2.38		
35	/	/	/	/	/	/	/	/	/	/	/	/	/	/	/	/	/	/	/	
65	-28	/	/	/	/	/	/	/	/	/	/	/	/	/	/	/	/	/	/	
	-20	/	/	/	/	/	/	/	/	/	/	/	/	/	/	/	/	/	/	
	-15	/	/	/	/	/	/	/	/	/	/	/	/	/	/	/	/	/	/	
	-10	/	/	/	/	/	/	/	/	/	/	/	/	/	/	/	/	/	/	
	-7	/	/	/	/	/	/	/	/	/	/	/	/	/	/	/	/	/	/	
	-5	/	/	/	/	/	/	/	/	/	/	/	/	/	/	/	/	/	/	
	-2	/	/	/	/	/	/	/	/	/	/	/	/	/	/	/	/	/	/	
	0	/	/	/	/	/	/	/	/	/	/	/	/	/	/	/	/	/	/	
	2	/	/	/	/	/	/	/	/	/	/	/	/	/	/	/	/	/	/	/
	5	14.79	2.50	5.91	13.74	2.14	6.42	10.41	2.29	4.55	9.28	2.31	4.02	9.28	2.31	4.02	9.28	2.31	4.02	
	7	15.49	2.61	5.94	13.88	2.45	5.67	10.95	2.51	4.36	9.99	2.60	3.84	9.79	2.62	3.74	9.79	2.62	3.74	
	10	16.57	2.78	5.97	13.45	2.73	4.93	11.04	2.74	4.03	10.11	2.84	3.56	9.39	2.87	3.27	9.39	2.87	3.27	
	12	13.49	2.93	4.61	12.35	2.78	4.44	11.07	2.88	3.84	10.32	2.89	3.57	10.19	2.92	3.49	10.19	2.92	3.49	
	15	13.89	3.02	4.60	13.89	3.02	4.60	10.75	2.92	3.68	10.27	2.95	3.48	10.27	2.95	3.48	10.27	2.95	3.48	
	20	/	/	/	/	/	/	/	/	/	/	/	/	/	/	/	/	/	/	/
25	/	/	/	/	/	/	/	/	/	/	/	/	/	/	/	/	/	/	/	
30	/	/	/	/	/	/	/	/	/	/	/	/	/	/	/	/	/	/	/	
35	/	/	/	/	/	/	/	/	/	/	/	/	/	/	/	/	/	/	/	

Abbreviations:

LWT: Leaving water temperature (°C)

DB: Dry-bulb temperature for Outdoor air temperature (°C)

HC: Total heating capacity (kW)

PI: Power input (kW)

6.2 Cooling Capacity Tables (Test standard: EN14511)

MHA-V12~16 model (12kW) cooling capacity

LWT	DB	Maximum			100%(Normal)			75%			50%			25%			Minimum		
		CC	EER	PI	CC	EER	PI	CC	EER	PI	CC	EER	PI	CC	EER	PI	CC	EER	PI
5	-5	/	/	/	/	/	/	/	/	/	/	/	/	/	/	/	/	/	/
	0	/	/	/	/	/	/	/	/	/	/	/	/	/	/	/	/	/	/
	5	/	/	/	/	/	/	/	/	/	/	/	/	/	/	/	/	/	/
	10	/	/	/	/	/	/	/	/	/	/	/	/	/	/	/	/	/	/
	15	/	/	/	/	/	/	/	/	/	/	/	/	/	/	/	/	/	/
	19	9.27	5.07	1.83	9.27	5.07	1.83	8.16	5.17	1.58	5.47	5.52	0.99	4.23	5.67	0.75	4.23	5.67	0.75
	20	9.26	4.78	1.94	9.26	4.78	1.94	8.01	4.90	1.64	5.39	5.23	1.03	4.16	5.39	0.77	4.16	5.39	0.77
	25	9.39	4.11	2.28	9.39	4.11	2.28	7.73	4.27	1.81	5.16	4.64	1.11	3.88	4.80	0.81	3.88	4.80	0.81
	30	9.84	3.18	3.09	9.84	3.18	3.09	7.55	3.40	2.22	5.03	3.76	1.34	3.61	3.94	0.92	3.61	3.94	0.92
	35	9.95	2.76	3.61	9.95	2.76	3.61	7.53	2.98	2.52	5.11	3.34	1.53	3.43	3.56	0.96	3.43	3.56	0.96
	40	6.68	2.18	3.07	6.68	2.18	3.07	5.28	2.35	2.25	3.53	2.66	1.33	2.28	2.86	0.80	2.28	2.86	0.80
43	4.38	1.69	2.59	4.38	1.69	2.59	3.67	1.80	2.04	2.50	2.05	1.22	1.51	2.24	0.67	1.51	2.24	0.67	
7	-5	/	/	/	/	/	/	/	/	/	/	/	/	/	/	/	/	/	/
	0	/	/	/	/	/	/	/	/	/	/	/	/	/	/	/	/	/	/
	5	/	/	/	/	/	/	/	/	/	/	/	/	/	/	/	/	/	/
	10	/	/	/	/	/	/	/	/	/	/	/	/	/	/	/	/	/	/
	15	/	/	/	/	/	/	/	/	/	/	/	/	/	/	/	/	/	/
	19	9.87	5.52	1.79	9.87	5.52	1.79	8.25	5.66	1.46	5.42	6.04	0.90	4.53	6.15	0.74	4.53	6.15	0.74
	20	9.90	5.11	1.94	9.90	5.11	1.94	8.12	5.27	1.54	5.55	5.62	0.99	4.47	5.75	0.78	4.47	5.75	0.78
	25	10.01	4.36	2.30	10.01	4.36	2.30	7.84	4.57	1.72	5.13	4.97	1.03	4.17	5.09	0.82	4.17	5.09	0.82
	30	10.09	3.61	2.79	10.09	3.61	2.79	7.59	3.92	1.94	5.03	4.33	1.16	3.89	4.48	0.87	3.89	4.48	0.87
	35	10.00	3.01	3.32	10.00	3.01	3.32	7.56	3.38	2.23	5.14	3.75	1.37	3.70	3.93	0.94	3.70	3.93	0.94
	40	7.11	2.28	3.12	7.11	2.28	3.12	5.30	2.50	2.12	3.56	2.83	1.26	2.46	3.00	0.82	2.46	3.00	0.82
43	4.61	1.79	2.58	4.61	1.79	2.58	3.67	1.92	1.91	2.44	2.20	1.11	1.63	2.36	0.69	1.63	2.36	0.69	
10	-5	/	/	/	/	/	/	/	/	/	/	/	/	/	/	/	/	/	/
	0	/	/	/	/	/	/	/	/	/	/	/	/	/	/	/	/	/	/
	5	/	/	/	/	/	/	/	/	/	/	/	/	/	/	/	/	/	/
	10	/	/	/	/	/	/	/	/	/	/	/	/	/	/	/	/	/	/
	15	9.94	7.49	1.33	9.94	7.49	1.33	6.96	8.45	0.82	5.28	8.87	0.60	5.28	8.87	0.60	5.28	8.87	0.60
	19	9.94	6.46	1.54	9.94	6.46	1.54	6.81	7.89	0.86	5.13	8.30	0.62	5.13	8.30	0.62	5.13	8.30	0.62
	20	10.06	6.00	1.68	10.06	6.00	1.68	6.97	7.56	0.92	5.07	8.09	0.63	5.07	8.09	0.63	5.07	8.09	0.63
	25	10.05	4.65	2.16	10.05	4.65	2.16	7.04	6.09	1.16	5.01	6.73	0.74	4.78	6.80	0.70	4.78	6.80	0.70
	30	10.03	4.06	2.47	10.03	4.06	2.47	6.95	4.66	1.49	5.00	5.45	0.92	4.55	5.54	0.82	4.55	5.54	0.82
	35	9.98	3.49	2.86	9.98	3.49	2.86	7.04	3.73	1.89	4.95	4.38	1.13	4.29	4.40	0.97	4.29	4.40	0.97
	40	9.16	3.01	3.04	9.16	3.01	3.04	6.95	3.11	2.24	5.09	3.54	1.44	4.07	3.60	1.13	4.07	3.60	1.13
43	6.77	2.42	2.80	6.77	2.42	2.80	5.70	2.29	2.49	4.17	2.57	1.62	3.22	2.63	1.22	3.22	2.63	1.22	
11	-5	/	/	/	/	/	/	/	/	/	/	/	/	/	/	/	/	/	/
	0	/	/	/	/	/	/	/	/	/	/	/	/	/	/	/	/	/	/
	5	/	/	/	/	/	/	/	/	/	/	/	/	/	/	/	/	/	/
	10	9.91	8.81	1.12	9.91	8.81	1.12	8.62	8.87	0.97	8.62	8.87	0.97	8.62	8.87	0.97	8.62	8.87	0.97
	15	9.99	7.81	1.28	9.99	7.81	1.28	6.92	8.60	0.80	5.43	8.69	0.62	5.43	8.69	0.62	5.43	8.69	0.62
	19	9.99	6.75	1.48	9.99	6.75	1.48	7.01	8.13	0.86	5.28	8.58	0.62	5.28	8.58	0.62	5.28	8.58	0.62
	20	9.89	6.39	1.55	9.89	6.39	1.55	6.93	7.86	0.88	5.22	8.35	0.62	5.22	8.35	0.62	5.22	8.35	0.62
	25	9.89	4.93	2.01	9.89	4.93	2.01	7.03	6.31	1.12	4.92	6.99	0.70	4.92	6.99	0.70	4.92	6.99	0.70
	30	10.09	4.21	2.40	10.09	4.21	2.40	6.96	5.21	1.34	4.93	5.65	0.87	4.70	5.70	0.82	4.70	5.70	0.82
	35	10.04	3.59	2.79	10.04	3.59	2.79	7.04	3.85	1.83	5.10	4.40	1.16	4.44	4.62	0.96	4.44	4.62	0.96
	40	9.45	3.08	3.07	9.45	3.08	3.07	6.94	3.20	2.17	5.05	3.66	1.38	4.20	3.69	1.14	4.20	3.69	1.14
43	8.52	2.84	3.00	7.27	2.56	2.84	6.14	2.58	2.38	5.07	2.92	1.74	4.06	2.96	1.37	4.06	2.96	1.37	
15	-5	6.35	9.48	0.67	6.35	9.48	0.67	6.17	9.52	0.65	5.99	9.88	0.61	5.99	9.88	0.61	5.99	9.88	0.61
	0	6.89	9.20	0.75	6.89	9.20	0.75	6.69	9.43	0.71	6.49	9.56	0.68	6.49	9.56	0.68	6.49	9.56	0.68
	5	7.45	8.92	0.84	7.45	8.92	0.84	7.21	9.38	0.77	6.99	9.42	0.74	6.99	9.42	0.74	6.99	9.42	0.74
	10	10.13	8.46	1.20	10.13	8.46	1.20	9.54	9.31	1.03	9.54	9.37	1.02	9.54	9.37	1.02	9.54	9.37	1.02
	15	10.05	8.19	1.23	10.05	8.19	1.23	6.88	9.26	0.74	6.04	9.29	0.65	6.04	9.29	0.65	6.04	9.29	0.65
	19	10.11	7.99	1.27	10.11	7.99	1.27	7.02	9.16	0.77	5.91	9.21	0.64	5.91	9.21	0.64	5.91	9.21	0.64
20	10.01	7.59	1.32	10.01	7.59	1.32	6.95	9.10	0.76	5.84	9.17	0.64	5.84	9.17	0.64	5.84	9.17	0.64	

LWT	DB	Maximum			100%(Normal)			75%			50%			25%			Minimum		
		CC	EER	PI	CC	EER	PI	CC	EER	PI	CC	EER	PI	CC	EER	PI	CC	EER	PI
	25	10.07	5.84	1.72	10.07	5.84	1.72	6.87	7.17	0.96	5.54	7.81	0.71	5.54	7.81	0.71	5.54	7.81	0.71
	30	10.04	4.95	2.03	10.04	4.95	2.03	6.87	5.99	1.15	6.33	5.98	1.06	5.31	6.37	0.83	5.31	6.37	0.83
	35	10.20	4.08	2.50	10.20	4.08	2.50	7.02	4.78	1.47	5.05	5.17	0.98	5.05	5.17	0.98	5.05	5.17	0.98
	40	10.11	3.42	2.95	10.11	3.42	2.95	7.13	3.89	1.83	5.05	4.20	1.20	4.81	4.23	1.14	4.81	4.23	1.14
	43	9.26	3.12	2.97	9.26	3.12	2.97	7.09	3.21	2.21	5.08	3.64	1.40	4.65	3.78	1.23	4.65	3.78	1.23
18	-5	6.87	9.89	0.69	6.87	9.89	0.69	6.62	9.95	0.67	6.36	10.02	0.63	6.36	10.02	0.63	6.36	10.02	0.63
	0	7.43	9.61	0.77	7.43	9.61	0.77	6.97	9.89	0.70	6.12	9.91	0.62	6.12	9.91	0.62	6.12	9.91	0.62
	5	8.02	9.45	0.85	8.02	9.45	0.85	7.51	9.52	0.79	7.51	9.61	0.78	7.51	9.61	0.78	7.51	9.61	0.78
	10	8.89	9.32	0.95	8.89	9.24	0.96	8.31	9.37	0.89	8.13	9.43	0.86	8.13	9.43	0.86	8.13	9.43	0.86
	15	9.77	9.18	1.06	9.77	9.18	1.06	6.85	9.23	0.74	6.53	9.34	0.70	6.53	9.34	0.70	6.53	9.34	0.70
	19	10.01	8.70	1.15	10.01	8.70	1.15	7.02	8.76	0.80	6.41	8.81	0.73	6.41	8.81	0.73	6.41	8.81	0.73
	20	9.92	8.31	1.19	9.92	8.31	1.19	6.95	8.38	0.83	6.34	8.62	0.74	6.34	8.62	0.74	6.34	8.62	0.74
	25	10.11	6.63	1.53	10.11	6.63	1.53	6.91	8.00	0.86	6.04	8.55	0.71	6.04	8.55	0.71	6.04	8.55	0.71
	30	10.09	5.57	1.81	10.09	5.57	1.81	6.93	6.52	1.06	5.81	6.97	0.83	5.81	6.97	0.83	5.81	6.97	0.83
	35	10.00	4.25	2.35	10.00	4.25	2.35	6.90	5.38	1.28	5.54	5.68	0.98	5.54	5.68	0.98	5.54	5.68	0.98
	40	10.14	3.79	2.68	10.14	3.79	2.68	7.08	4.40	1.61	5.29	4.67	1.13	5.29	4.67	1.13	5.29	4.67	1.13
	43	10.11	3.40	2.97	10.11	3.40	2.97	7.07	3.92	1.80	5.11	4.20	1.22	5.11	4.20	1.22	5.11	4.20	1.22
20	-5	6.94	9.94	0.70	6.94	9.94	0.70	6.68	9.99	0.67	6.42	10.03	0.64	6.42	10.03	0.64	6.42	10.03	0.64
	0	8.87	9.82	0.90	8.87	9.82	0.90	8.29	9.85	0.84	8.29	9.95	0.83	8.29	9.95	0.83	8.29	9.95	0.83
	5	8.42	9.76	0.86	8.42	9.76	0.86	7.88	9.81	0.80	7.88	9.81	0.80	7.88	9.81	0.80	7.88	9.81	0.80
	10	10.83	9.53	1.14	10.83	9.53	1.14	10.83	9.73	1.11	10.83	9.79	1.11	10.83	9.79	1.11	10.83	9.79	1.11
	15	10.01	9.35	1.07	10.01	9.35	1.07	6.86	9.56	0.72	6.86	9.71	0.71	6.86	9.71	0.71	6.86	9.71	0.71
	19	9.94	9.31	1.07	9.94	9.31	1.07	7.09	9.38	0.76	6.76	9.48	0.71	6.76	9.48	0.71	6.76	9.48	0.71
	20	9.85	9.15	1.08	9.85	9.15	1.08	7.02	9.27	0.76	6.69	9.34	0.72	6.69	9.34	0.72	6.69	9.34	0.72
	25	10.02	7.06	1.42	10.02	7.06	1.42	7.01	8.66	0.81	6.39	9.13	0.70	6.39	9.13	0.70	6.39	9.13	0.70
	30	10.03	5.97	1.68	10.03	5.97	1.68	7.05	7.05	1.00	6.16	7.48	0.82	6.16	7.48	0.82	6.16	7.48	0.82
	35	9.96	4.97	2.00	9.96	4.97	2.00	7.02	5.71	1.23	5.89	6.11	0.96	5.89	6.11	0.96	5.89	6.11	0.96
	40	10.12	4.11	2.47	10.12	4.11	2.47	6.97	4.73	1.47	5.63	5.06	1.11	5.63	5.06	1.11	5.63	5.06	1.11
	43	10.09	3.68	2.74	10.09	3.68	2.74	7.00	4.32	1.62	5.44	4.56	1.19	5.44	4.56	1.19	5.44	4.56	1.19
25	-5	7.12	10.05	0.71	7.12	10.05	0.71	6.95	10.15	0.68	6.74	10.23	0.66	6.74	10.23	0.66	6.74	10.23	0.66
	0	9.82	9.85	1.00	9.82	9.85	1.00	9.28	10.01	0.93	9.28	10.12	0.92	9.28	10.12	0.92	9.28	10.12	0.92
	5	9.92	9.65	1.03	9.92	9.65	1.03	8.95	9.82	0.91	8.95	9.98	0.90	8.95	9.98	0.90	8.95	9.98	0.90
	10	10.23	9.59	1.07	10.23	9.59	1.07	10.13	9.61	1.05	10.13	9.79	1.03	10.13	9.79	1.03	10.13	9.79	1.03
	15	10.03	9.28	1.08	10.03	9.28	1.08	7.87	9.54	0.82	7.87	9.59	0.82	7.87	9.59	0.82	7.87	9.59	0.82
	19	9.95	9.18	1.08	9.95	9.18	1.08	7.71	9.29	0.83	7.71	9.55	0.81	7.71	9.55	0.81	7.71	9.55	0.81
	20	9.87	8.74	1.13	9.87	8.74	1.13	7.65	9.05	0.84	7.65	9.28	0.82	7.65	9.28	0.82	7.65	9.28	0.82
	25	9.83	7.23	1.36	9.83	7.23	1.36	7.35	7.48	0.98	7.35	8.95	0.82	7.35	8.95	0.82	7.35	8.95	0.82
	30	9.88	6.12	1.61	9.88	6.12	1.61	7.12	6.23	1.14	7.12	6.40	1.11	7.12	6.40	1.11	7.12	6.40	1.11
	35	10.07	5.39	1.87	10.07	5.39	1.87	7.16	5.50	1.30	6.83	5.73	1.19	6.83	5.73	1.19	6.83	5.73	1.19
	40	9.94	4.89	2.03	9.94	4.89	2.03	6.86	5.29	1.30	6.56	5.59	1.17	6.56	5.59	1.17	6.56	5.59	1.17
	43	10.24	4.66	2.20	10.24	4.66	2.20	6.94	5.09	1.36	6.34	5.50	1.15	6.34	5.50	1.15	6.34	5.50	1.15

Abbreviations:

LWT: Leaving water temperature (°C)

DB: Dry-bulb temperature for Outdoor air temperature (°C)

CC: Total cooling capacity (kW)

PI: Power input (kW)

7 Octave Band Sound Level

7.1 Outdoor unit

We measure noise of the unit from 4 sides as below, with a rated frequency at the distance of 1m.



The conditions we've tested is illustrated as below:

Heating A-7W35: Evaporator air in -7°C , 85% R.H., Condenser water in/out $30/35^{\circ}\text{C}$

Heating A7W35: Evaporator air in 7°C , 85% R.H., Condenser water in/out $30/35^{\circ}\text{C}$

Heating A7W45: Evaporator air in 7°C , 85% R.H., Condenser water in/out $40/45^{\circ}\text{C}$

Heating A7W55: Evaporator air in 7°C , 85% R.H., Condenser water in/out $47/55^{\circ}\text{C}$

Cooling A35W18: Condenser air in 35°C . Evaporator water in/out $23/18^{\circ}\text{C}$

Cooling A35W7: Condenser air in 35°C . Evaporator water in/out $12/7^{\circ}\text{C}$

Heating A-7W35

A B C D

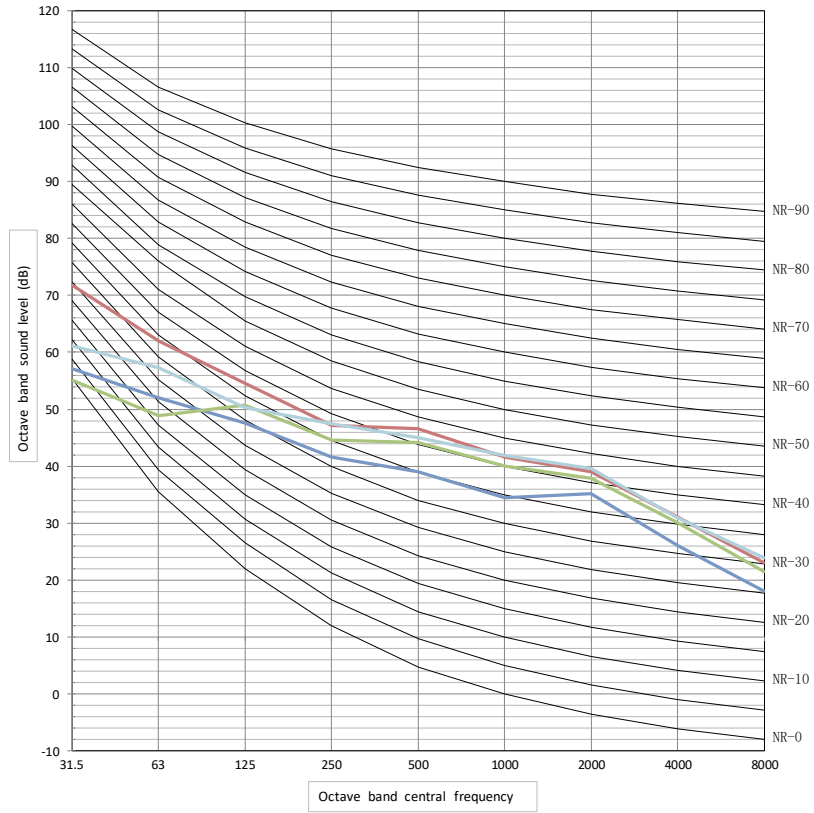

Heating A7W35

A B C D

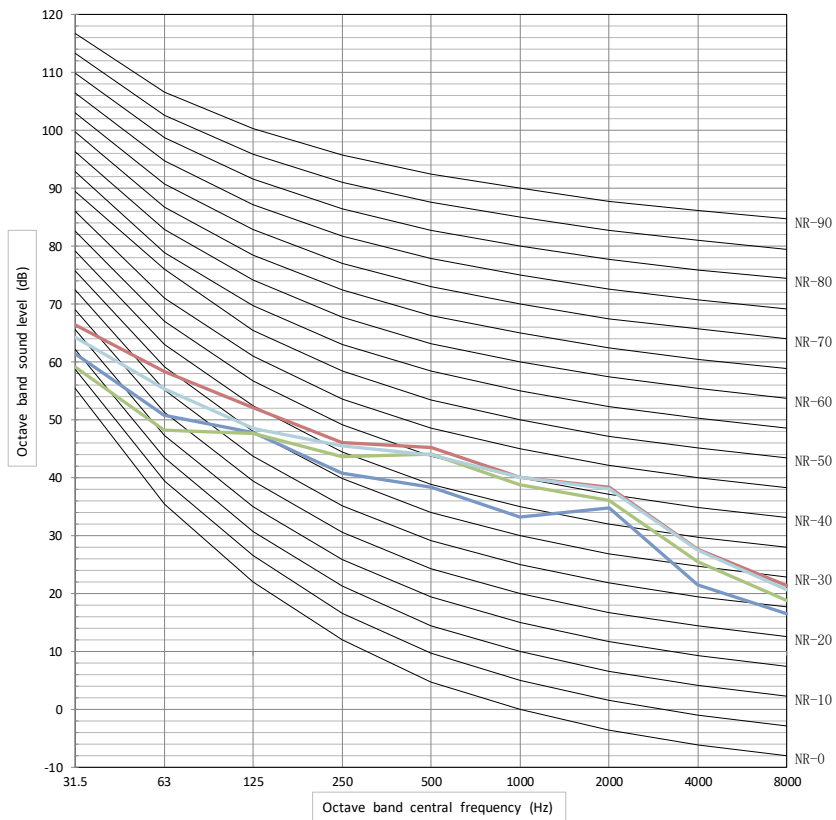

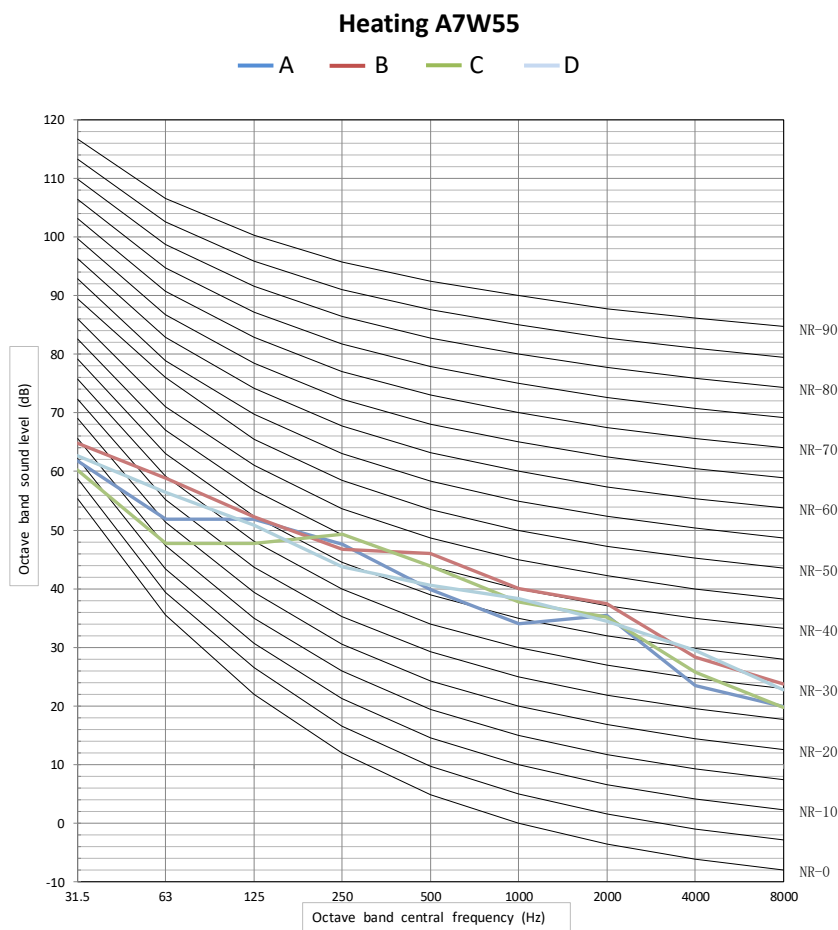
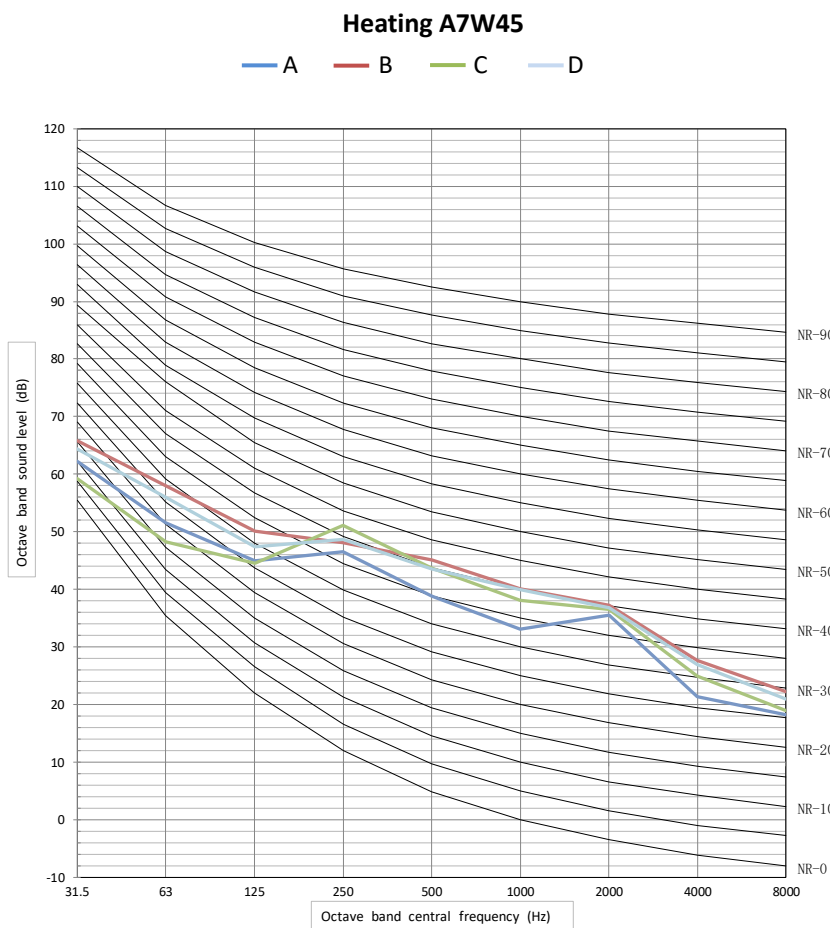

Cooling A35W18

A B C D

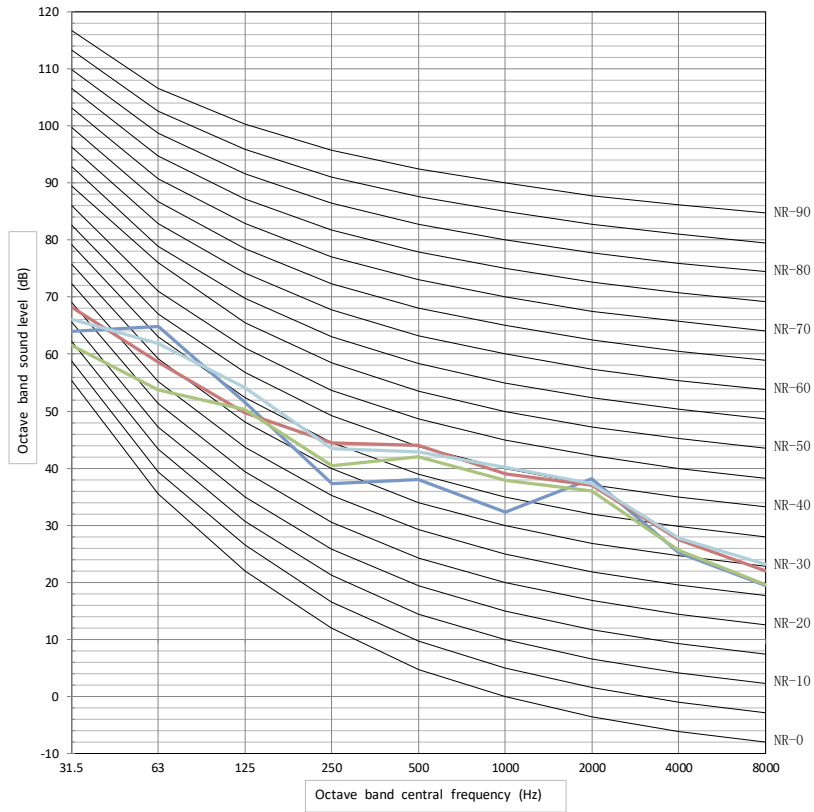

Cooling A35W7

A B C D

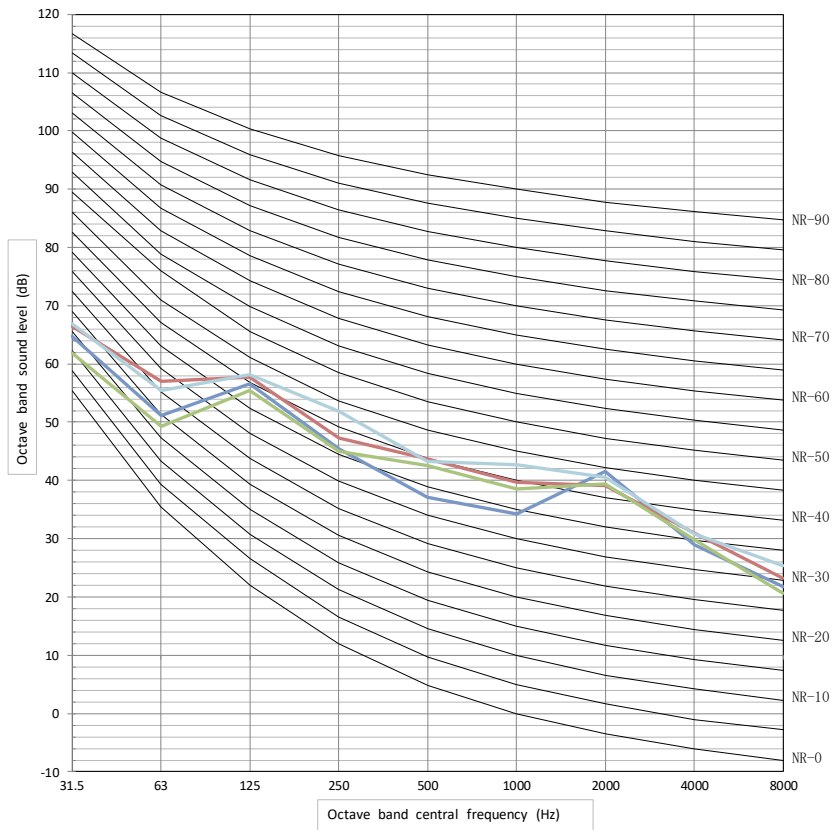

Heating A-7W35

— A — B — C — D

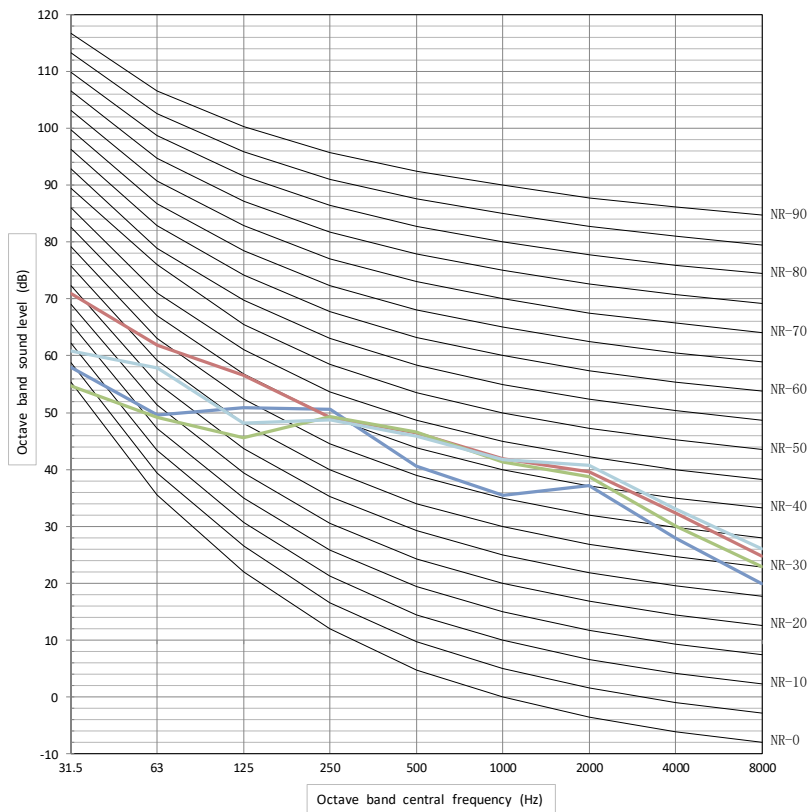

Heating A7W35

— A — B — C — D

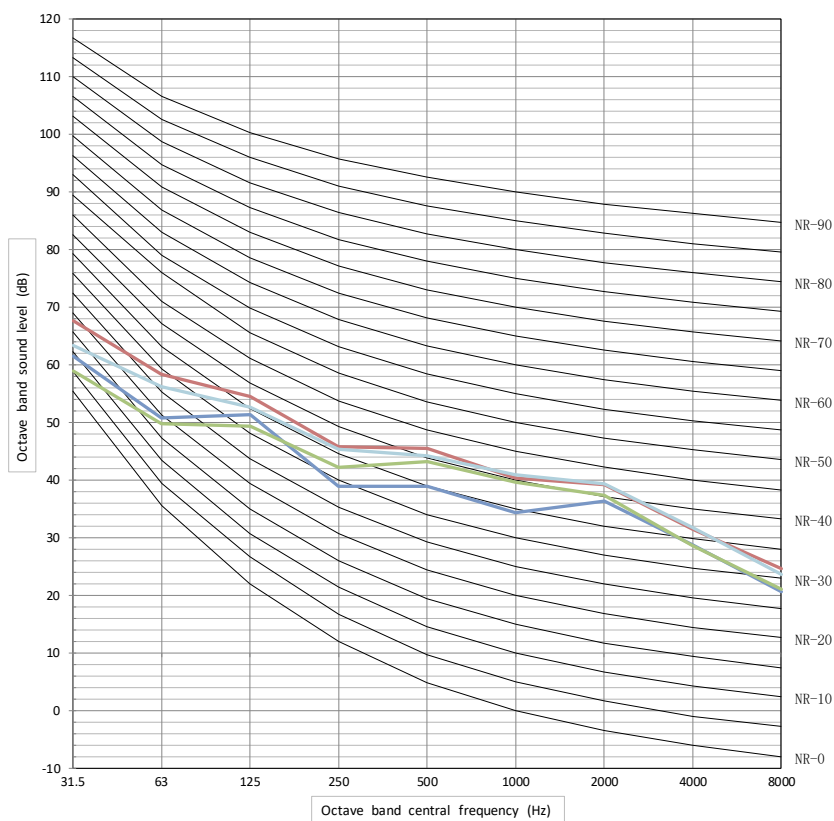

Heating A7W45

— A — B — C — D

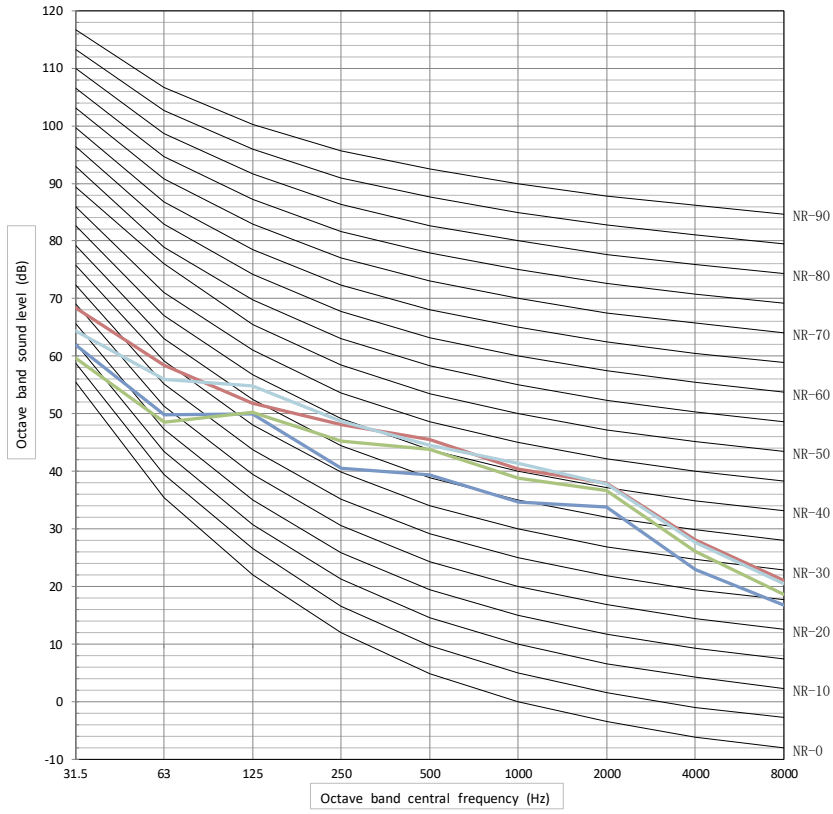

Heating A7W55

— A — B — C — D

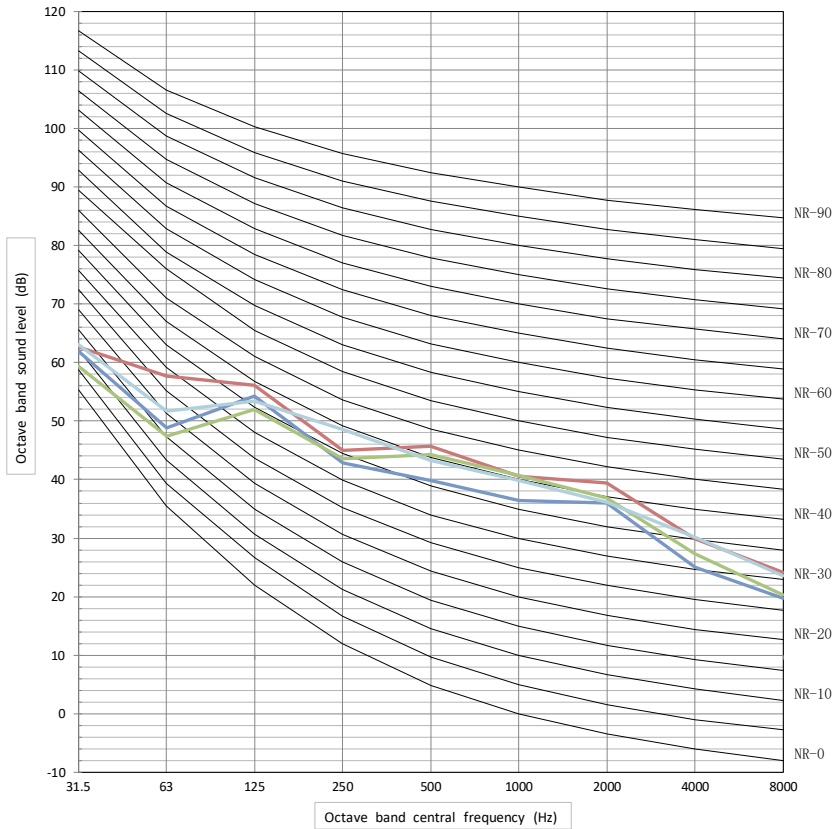

Cooling A35W18

— A — B — C — D

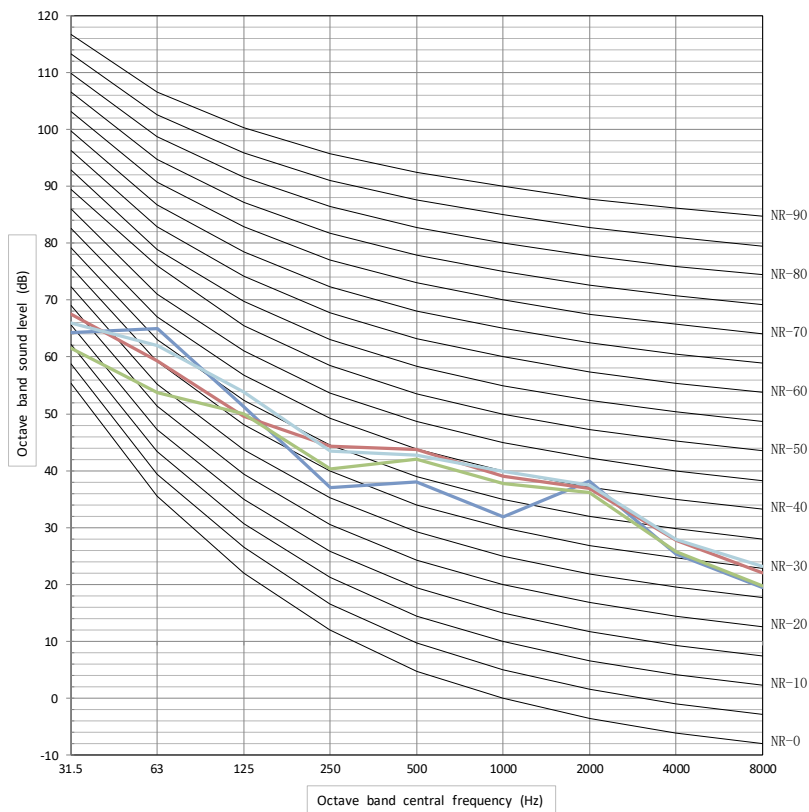

Cooling A35W7

— A — B — C — D

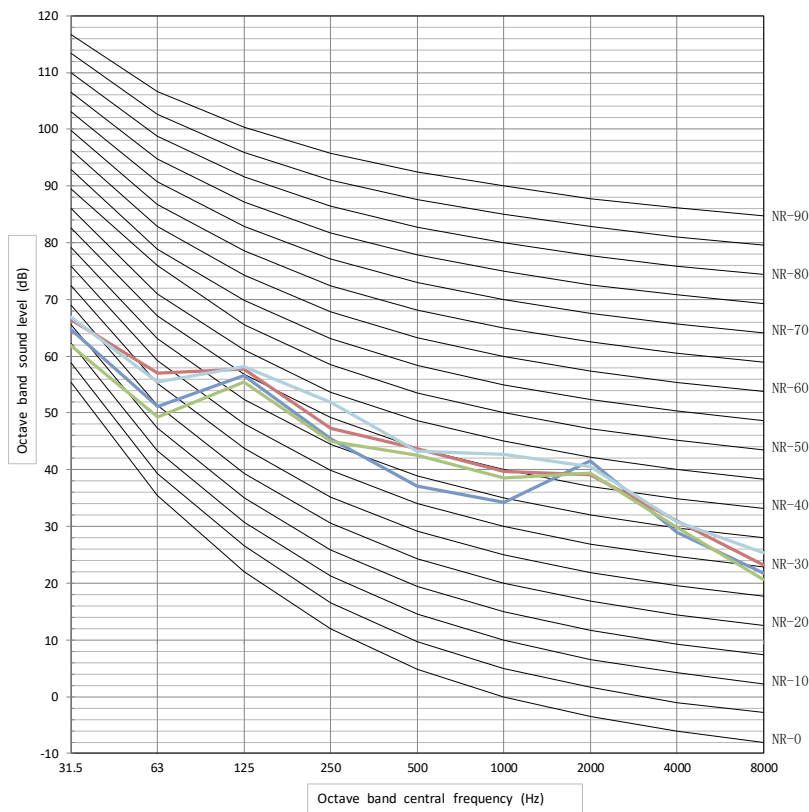

Heating A-7W35

A B C D

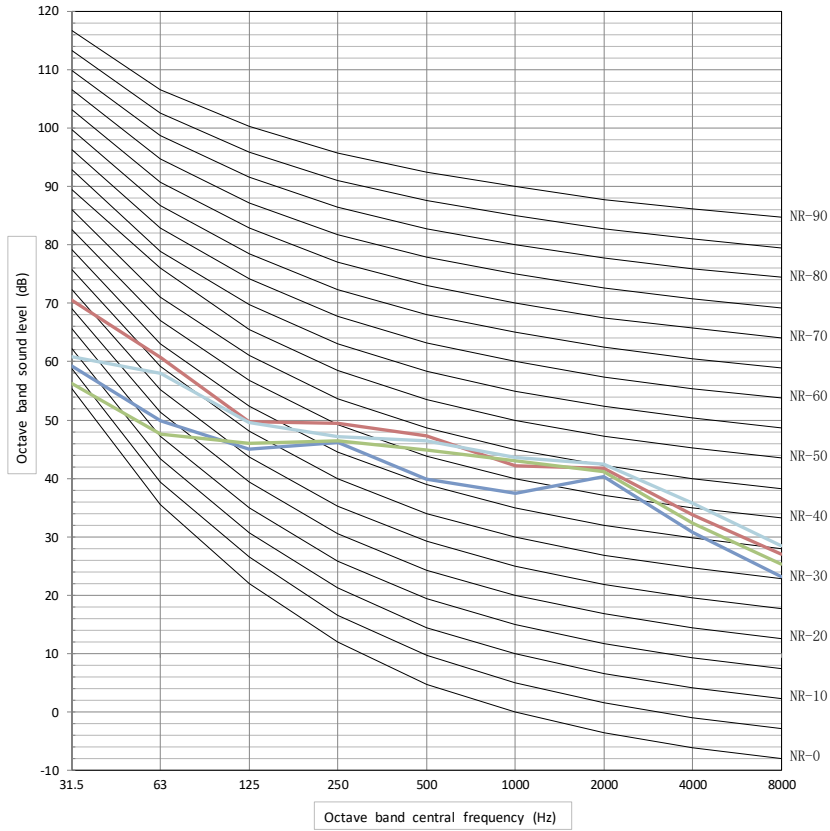

Heating A7W35

A B C D

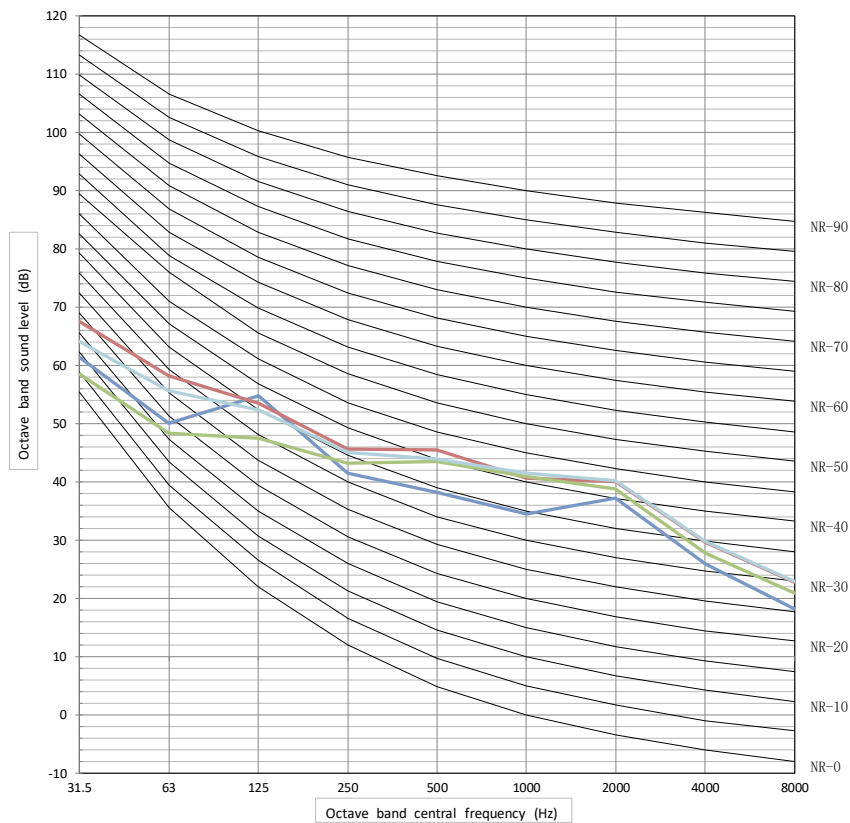

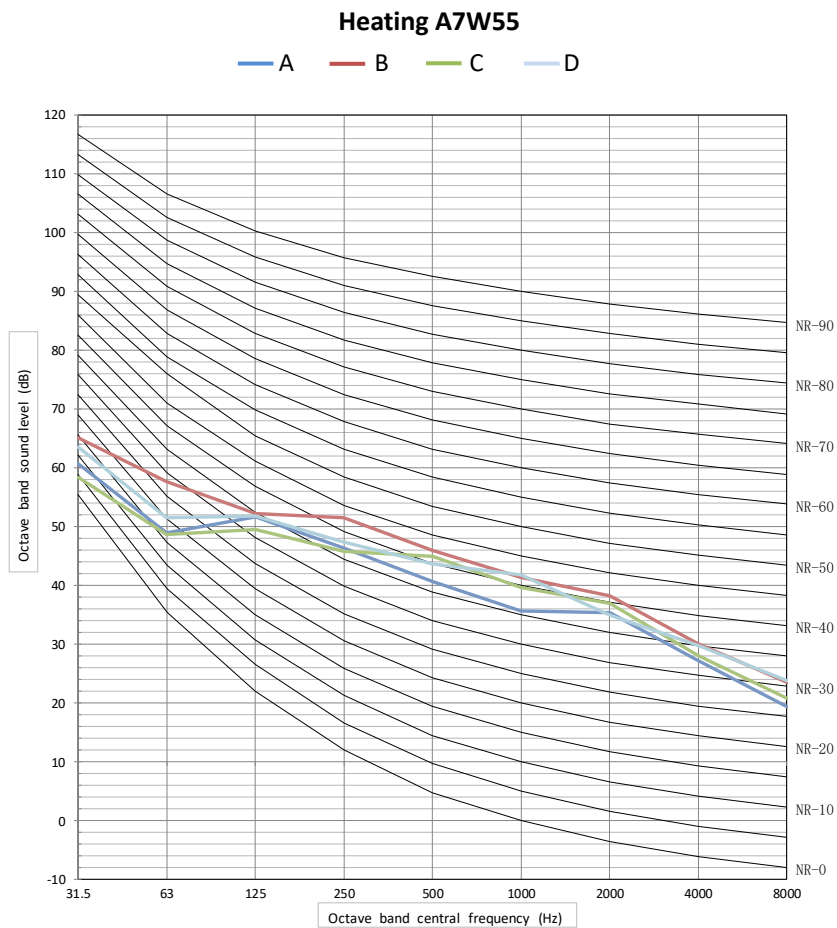
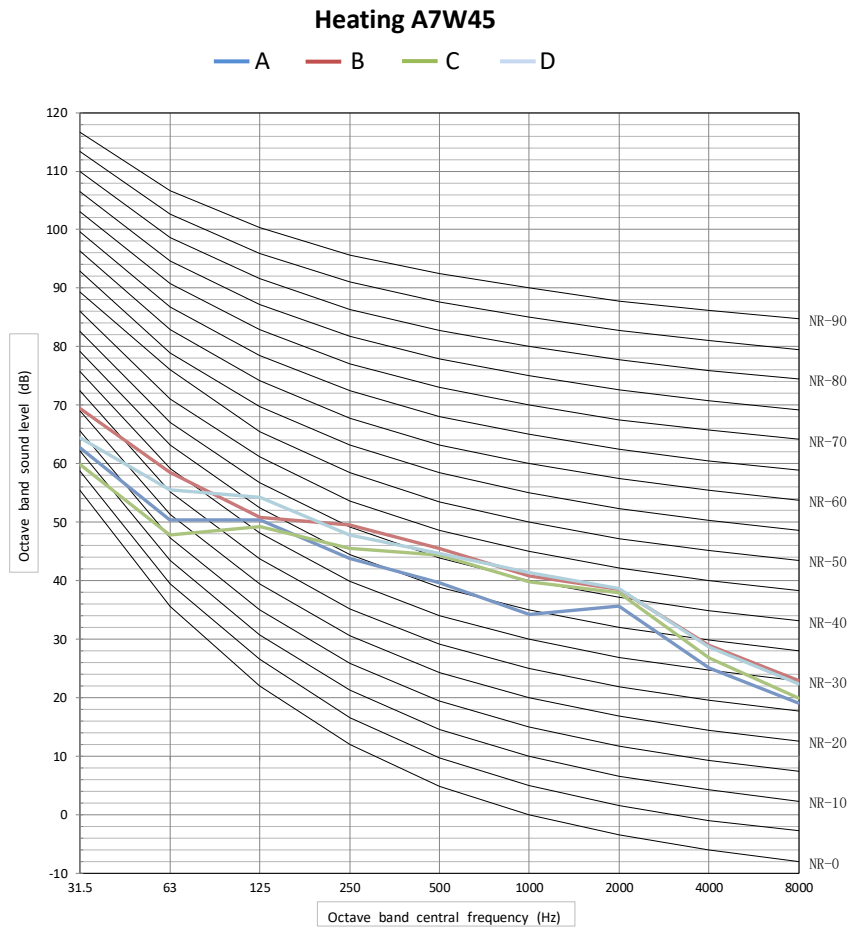

Cooling A35W18

A B C D

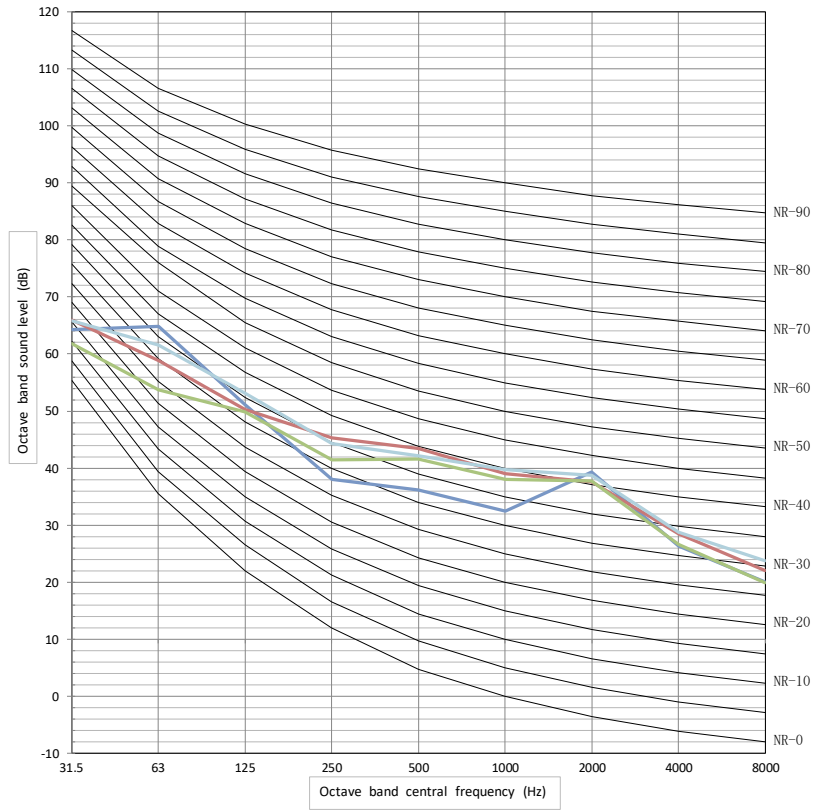

Cooling A35W7

A B C D

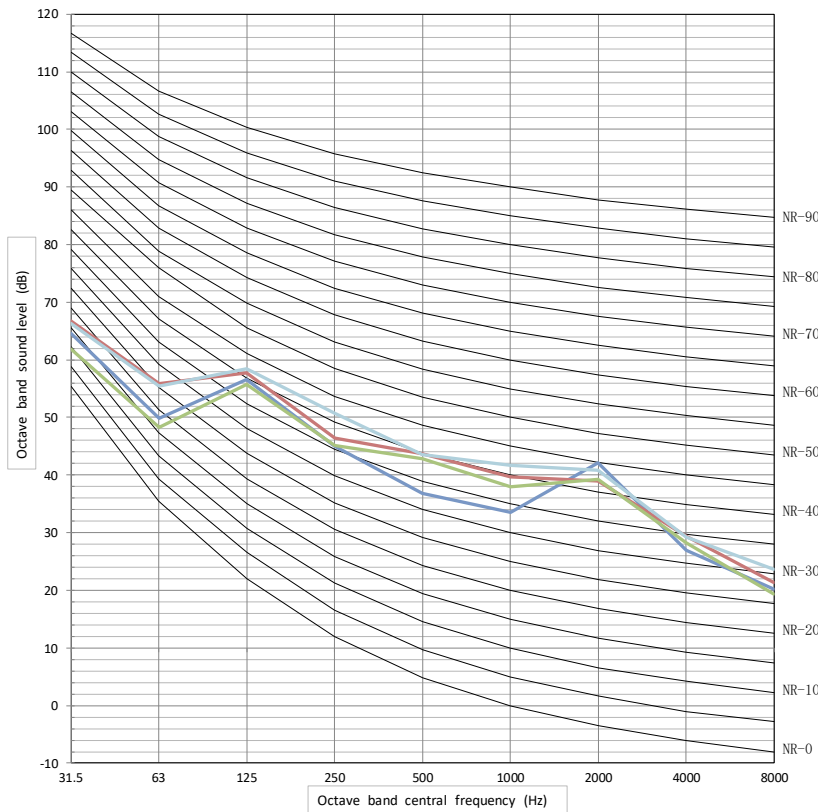

Heating A-7W35

— A — B — C — D

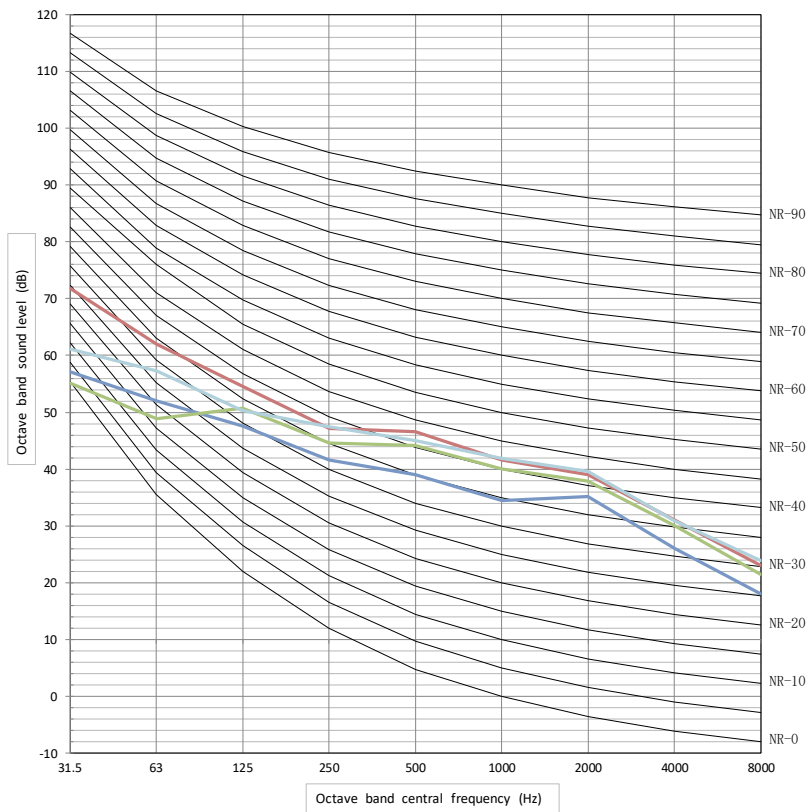

Heating A7W35

— A — B — C — D

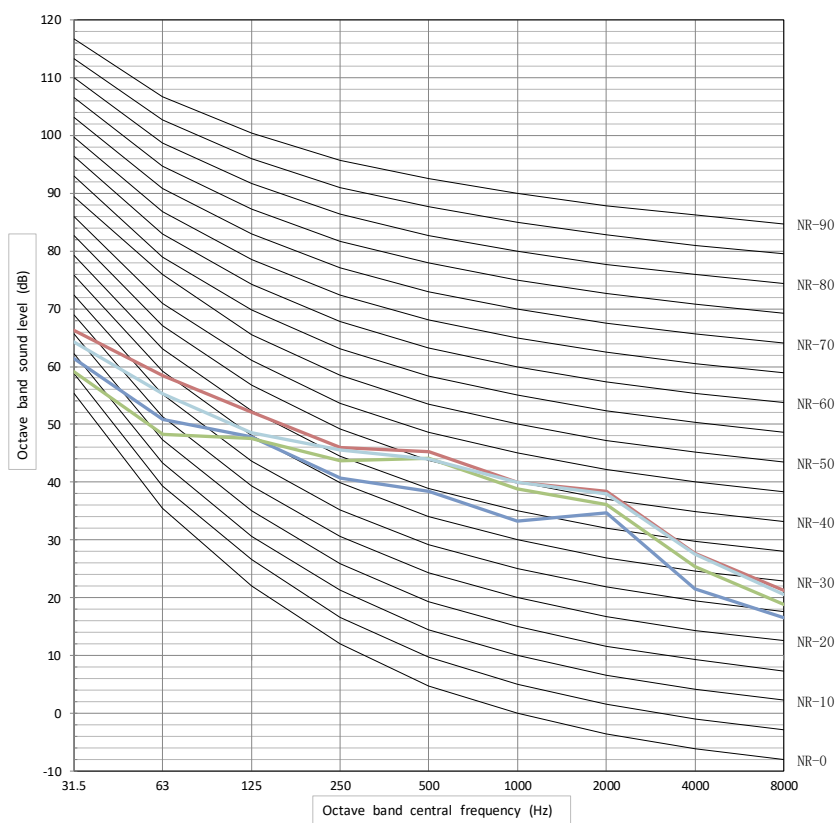

Heating A7W45

A B C D

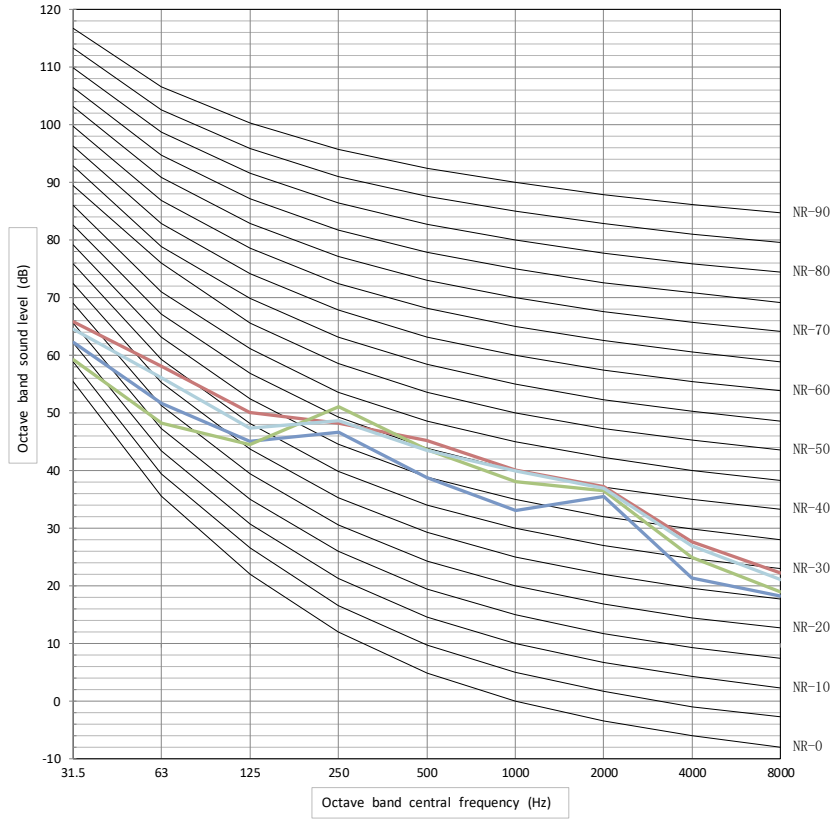

Heating A7W55

A B C D

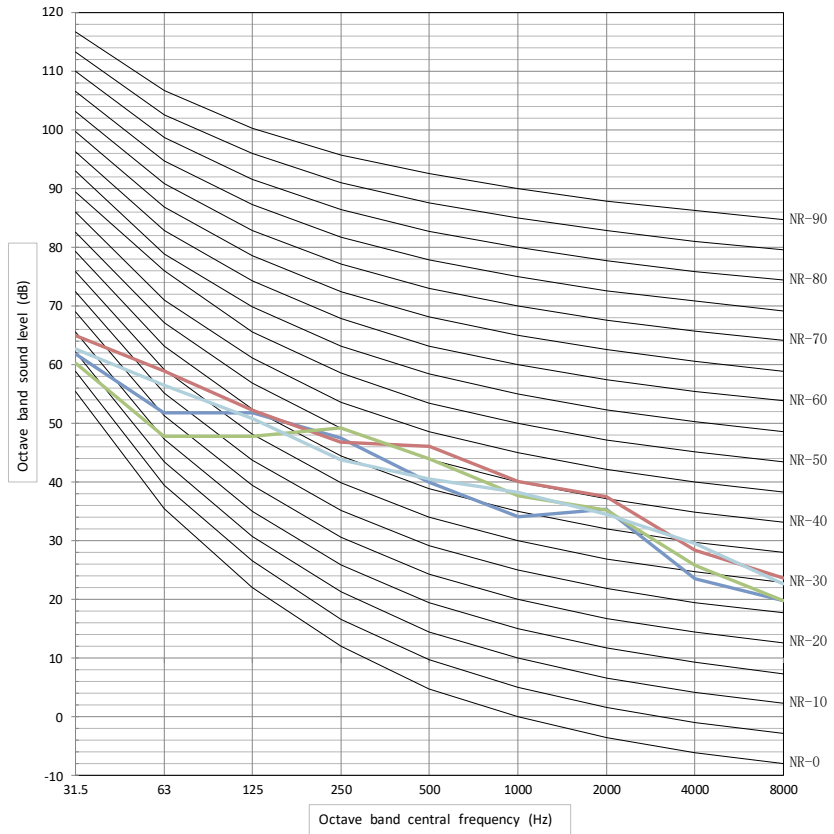

Cooling A35W18

— A — B — C — D

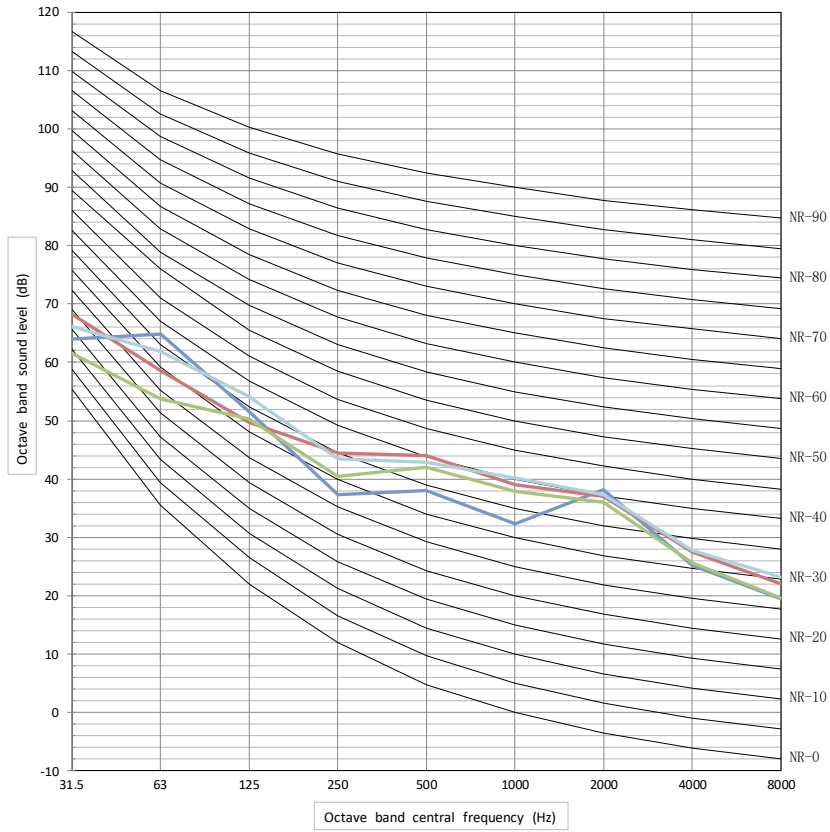

Cooling A35W7

— A — B — C — D

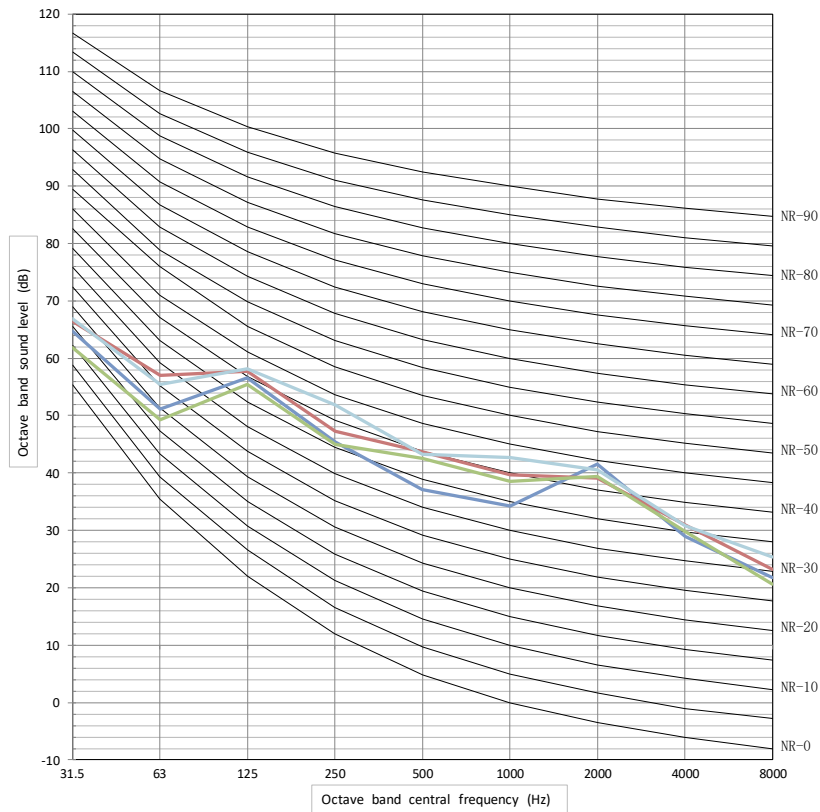

Heating A-7W35

A B C D

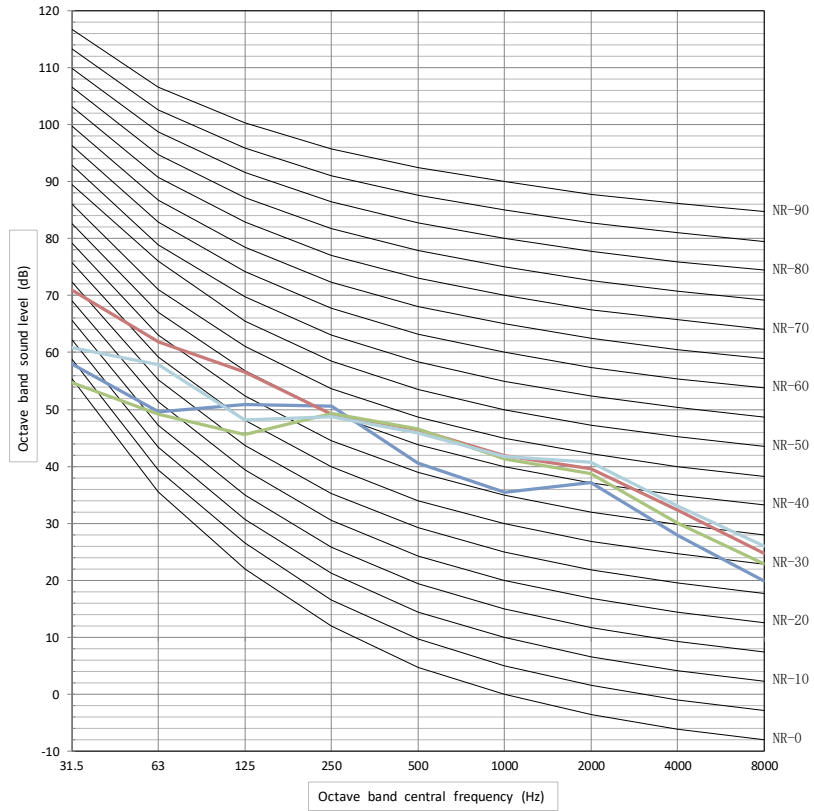

Heating A7W35

A B C D

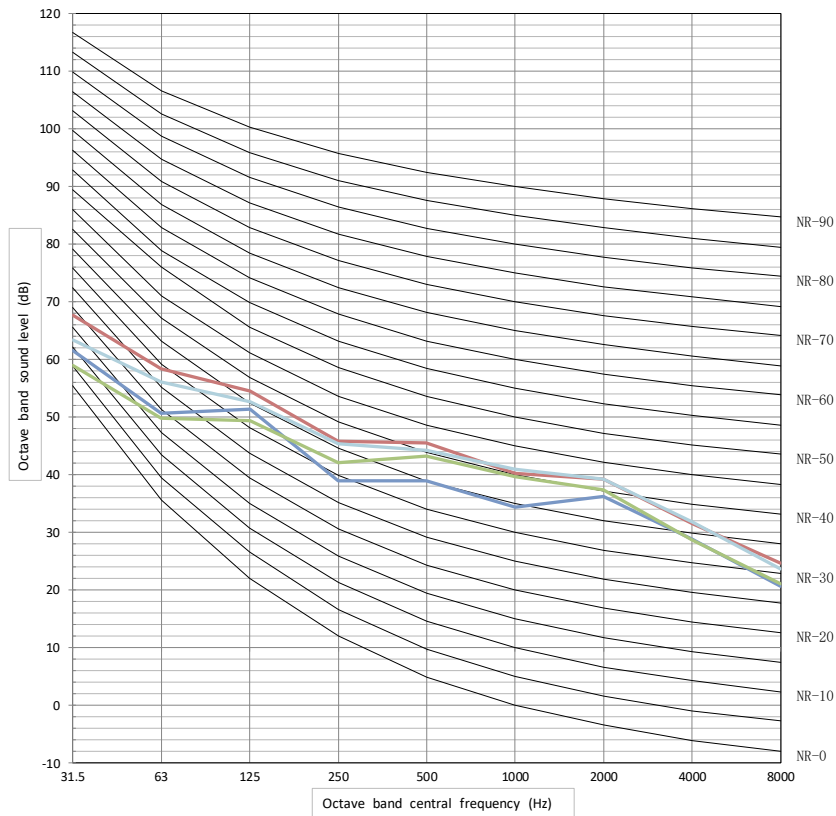

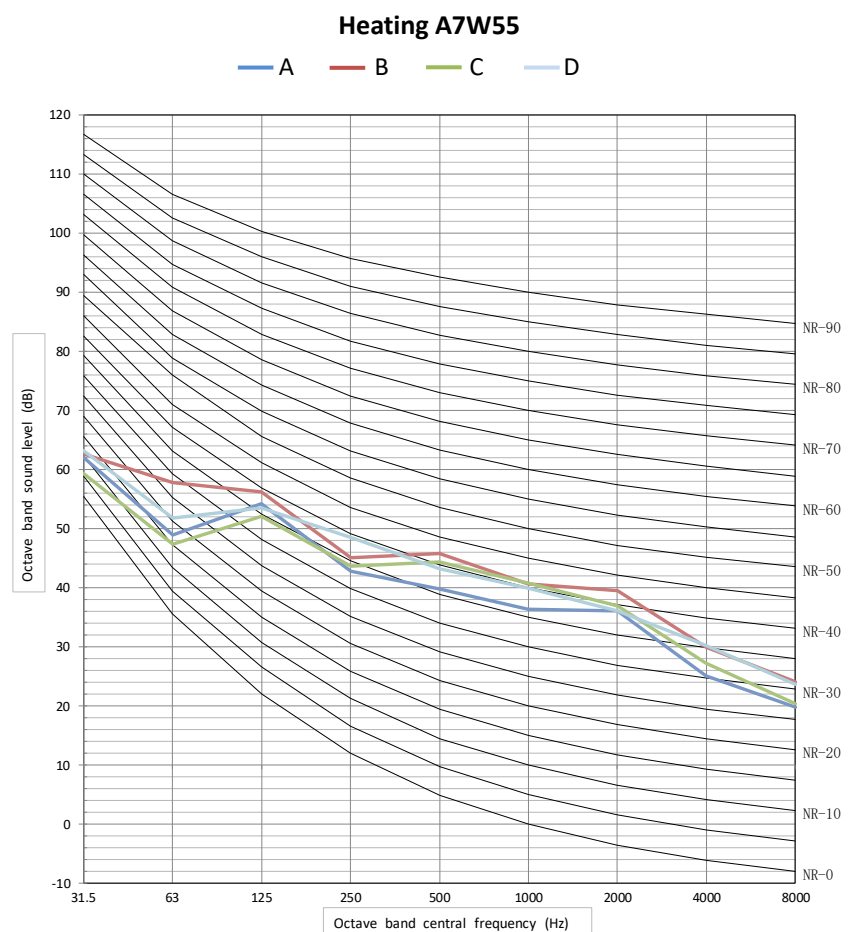
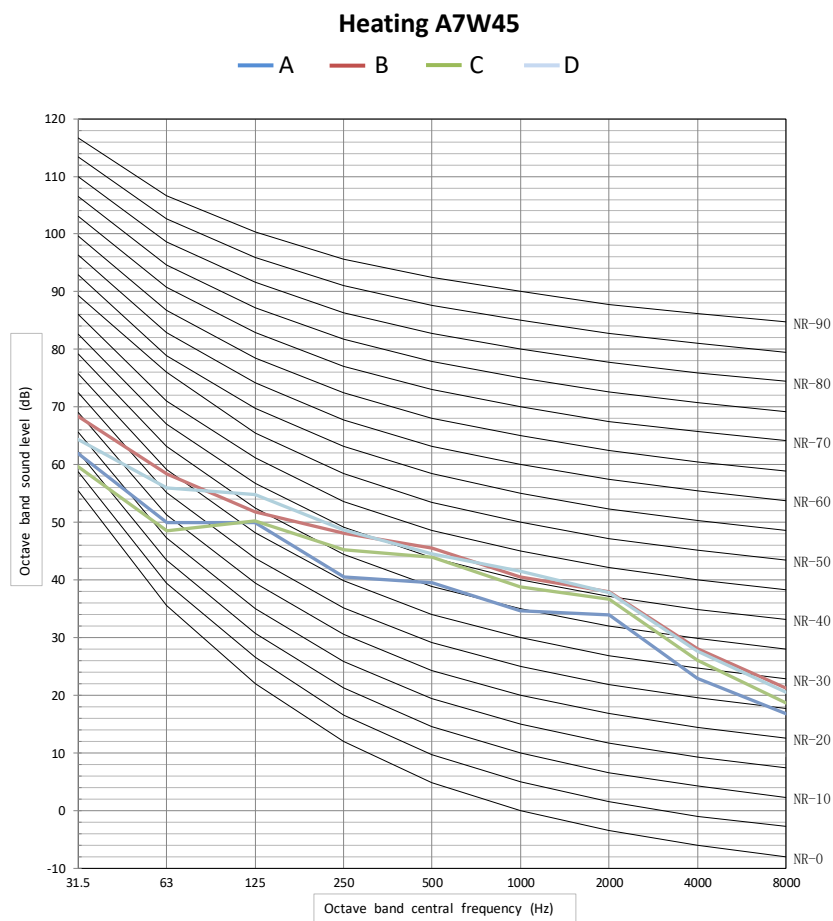

Cooling A35W18

A B C D

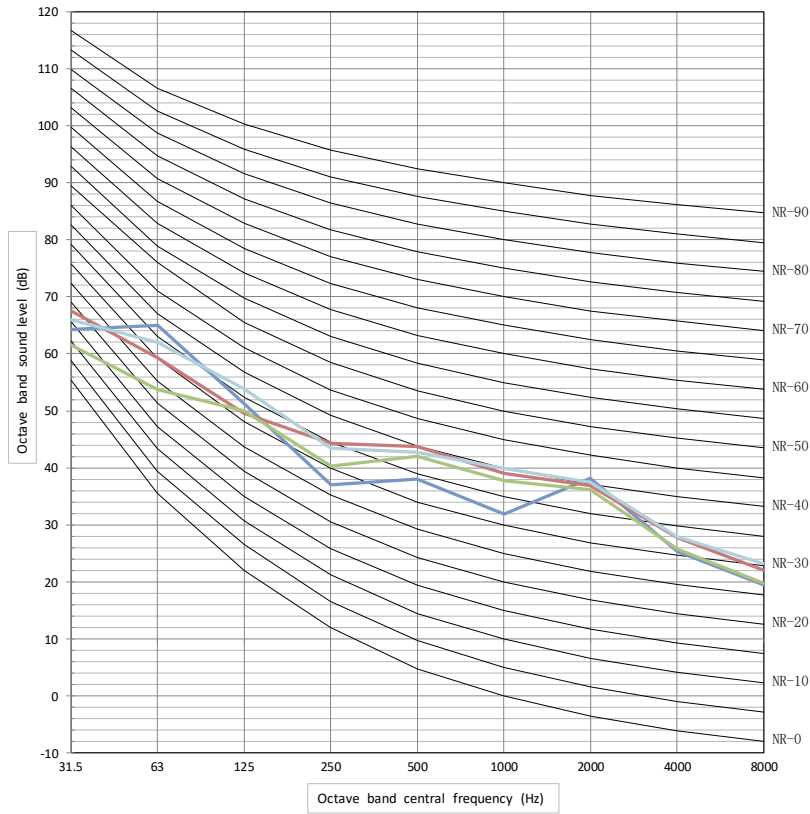

Cooling A35W7

A B C D

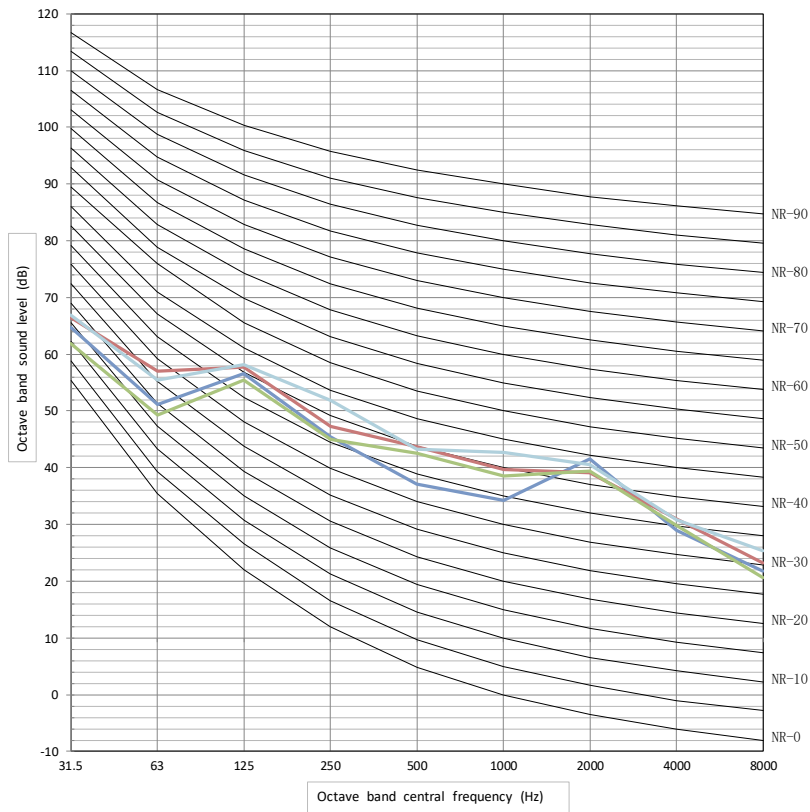

Heating A-7W35

— A — B — C — D

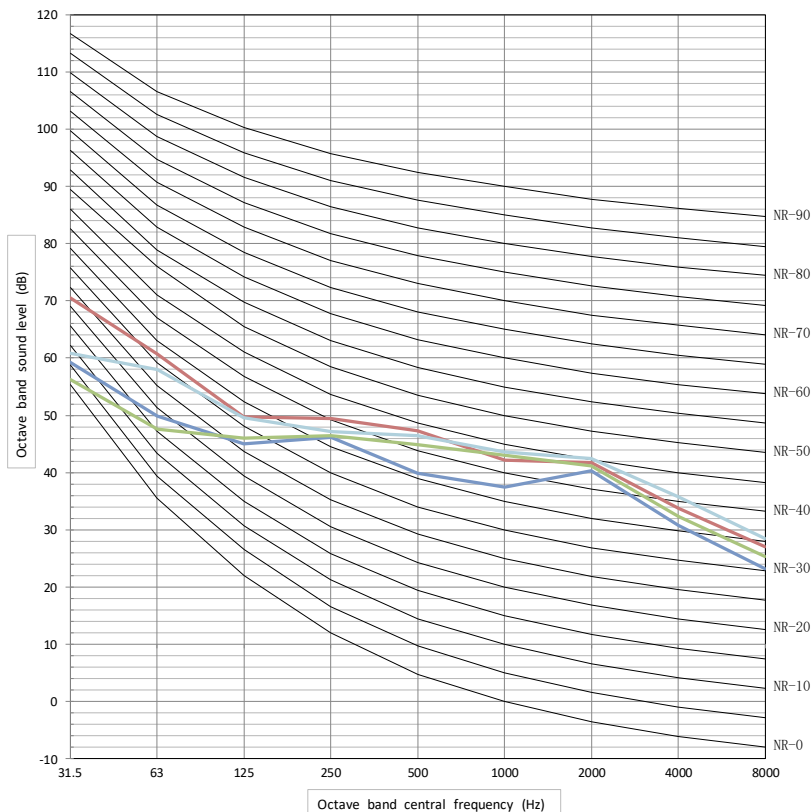

Heating A7W35

— A — B — C — D

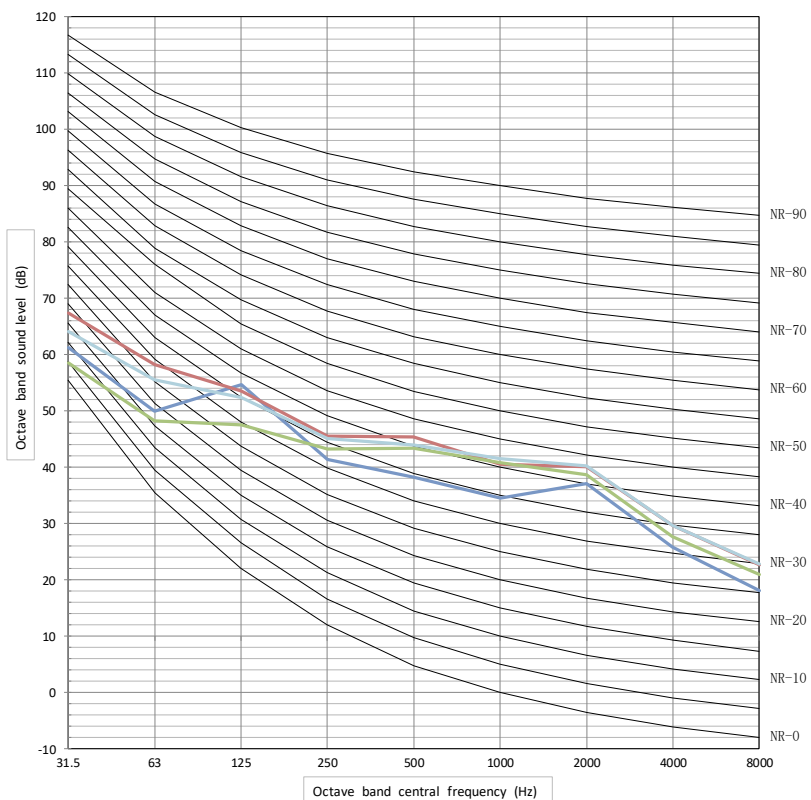

Heating A7W45

A B C D

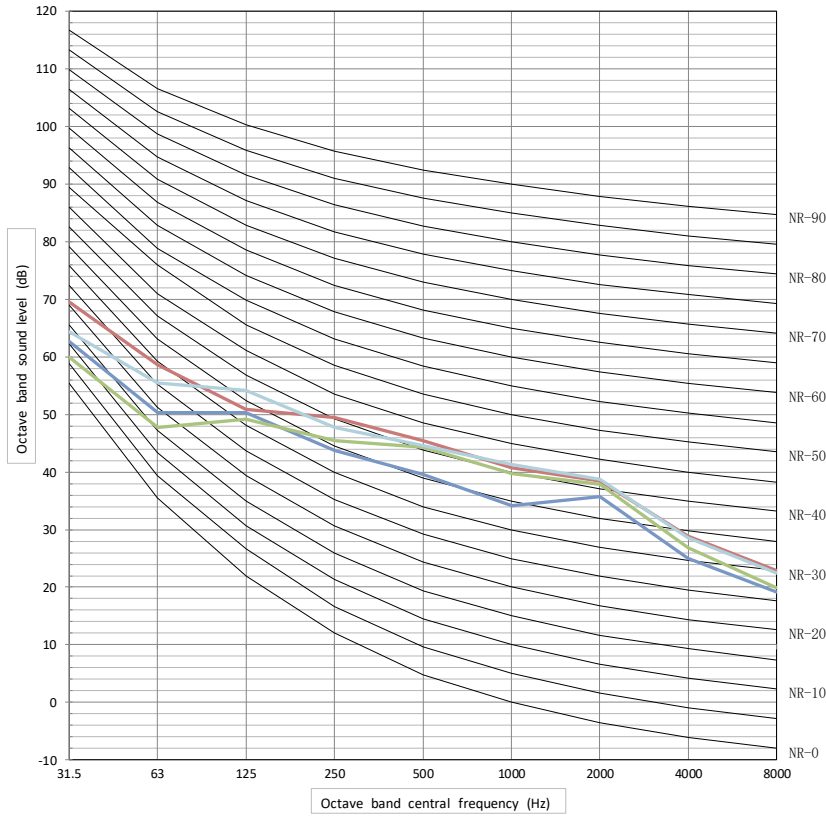

Heating A7W55

A B C D

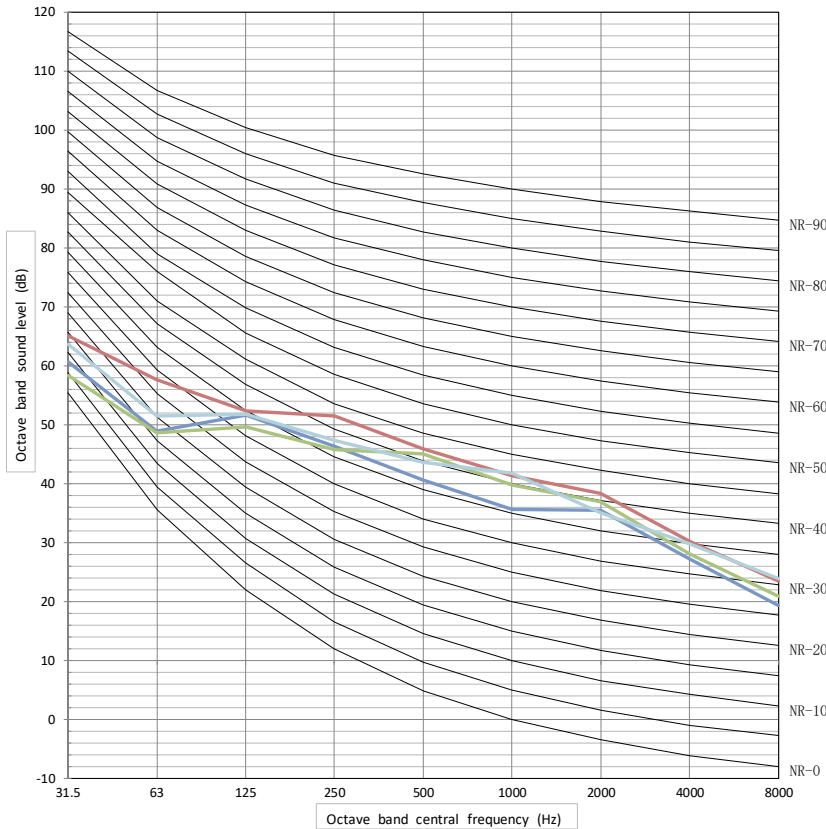

Cooling A35W18

— A — B — C — D

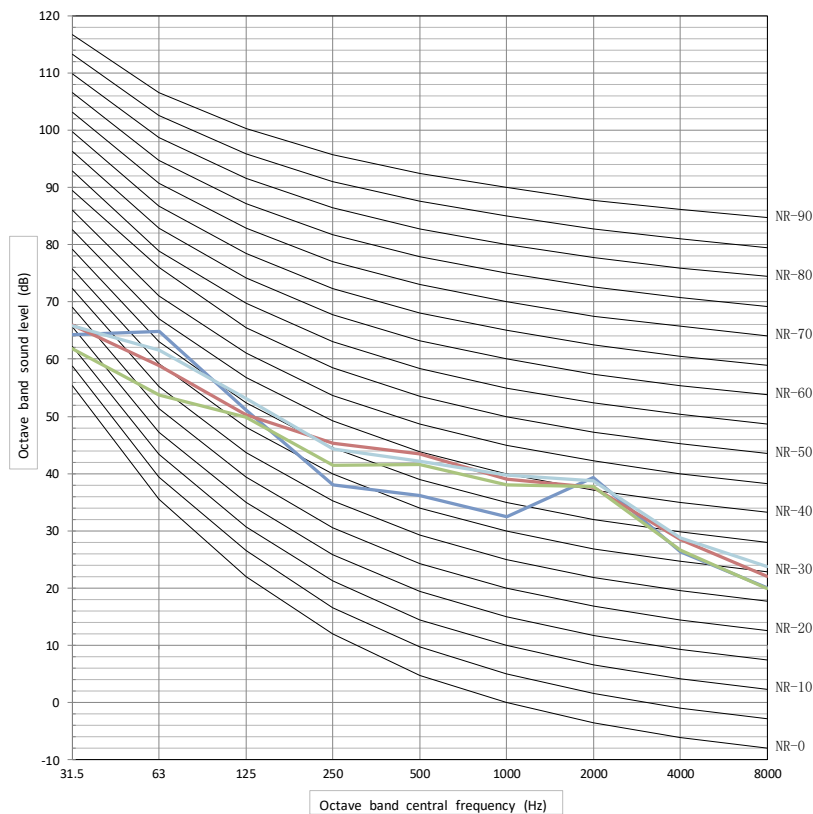

Cooling A35W7

— A — B — C — D

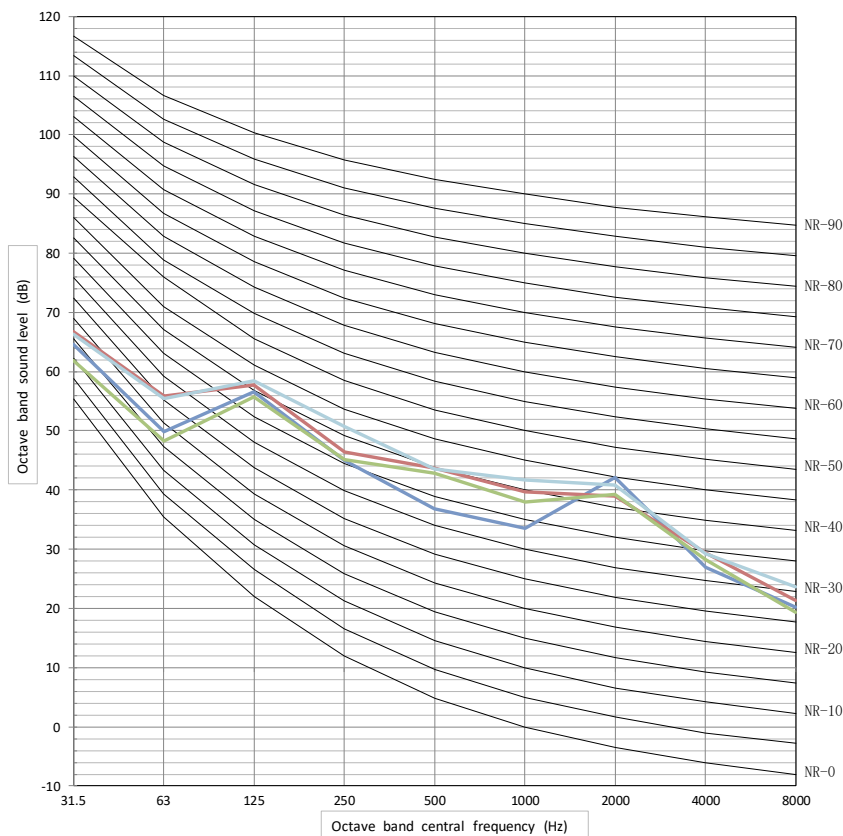

7.2 Indoor unit without water tank

We measure noise of the unit from 1 sides as below, with a rated frequency at the distance of 1m.



The conditions we've tested is illustrated as below:

Heating A7W35: Evaporator air in 7°C, 85% R.H., Condenser water in/out 30/35°C

Heating A7W55: Evaporator air in 7°C, 85% R.H., Condenser water in/out 47/55°C

Cooling A35W18: Condenser air in 35°C. Evaporator water in/out 23/18°C

Cooling A35W7: Condenser air in 35°C. Evaporator water in/out 12/7°C

Hygge Split

Indoor unit: 160 model + Outdoor unit: 12/14/16kW



Heating A7W35

— 16kW — 14kW — 12kW

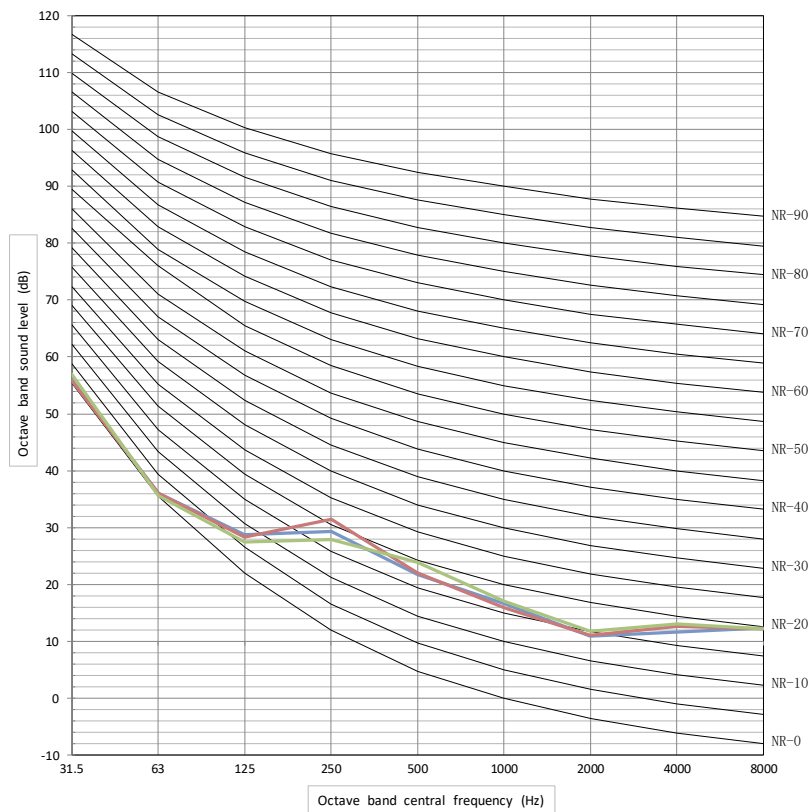

Heating A7W55

— 16kW — 14kW — 12kW

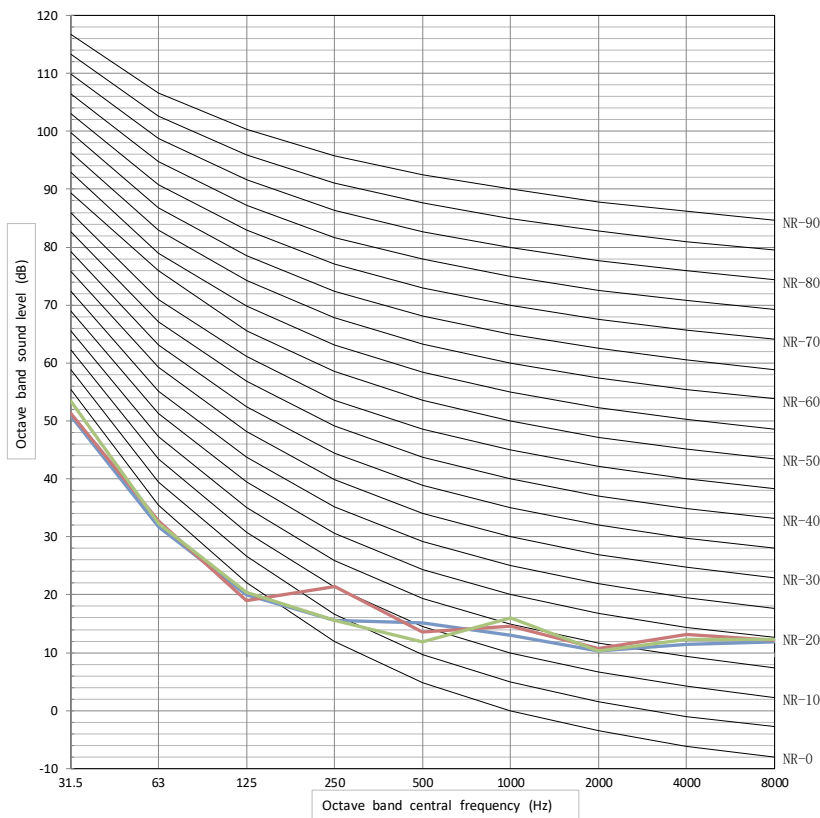

Cooling A35W18

— 12/14/16 kW

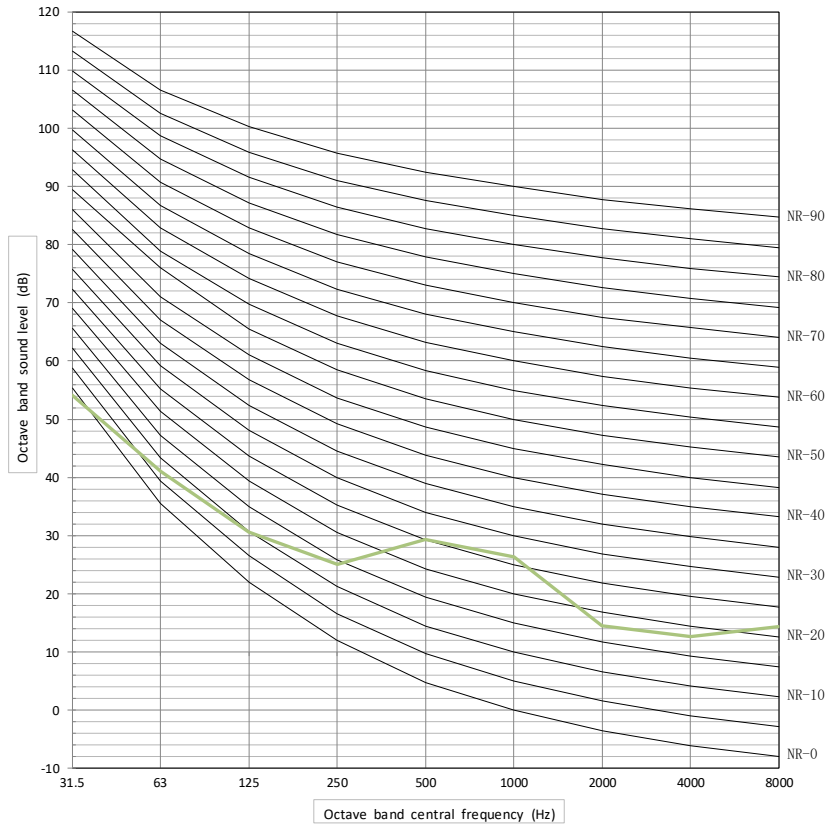

Cooling A35W7

— 12/14/16 kW

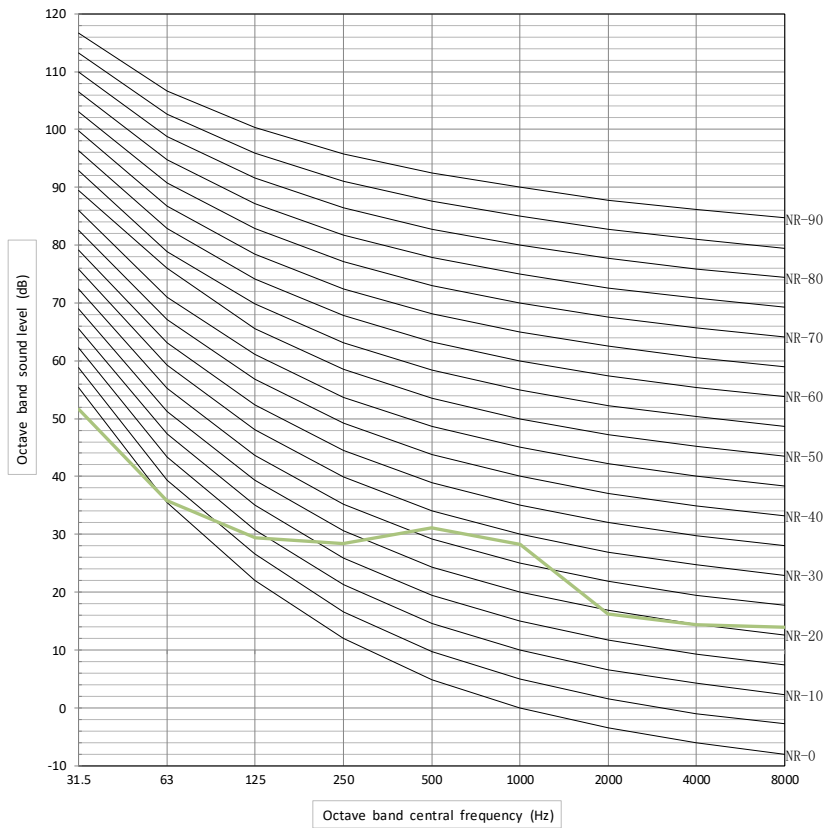

7.3 Indoor unit with water tank

We measure noise of the unit from 1 sides as below, with a rated frequency at the distance of 1m.

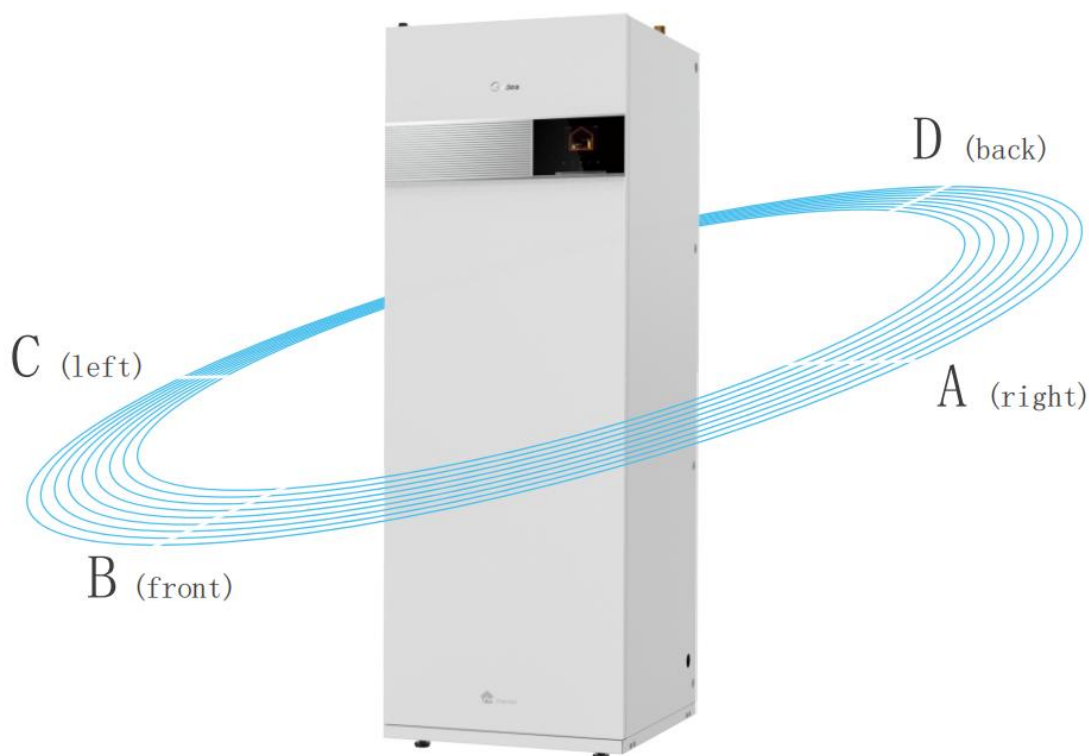

The conditions we've tested is illustrated as below:

Heating A7W35: Evaporator air in 7°C, 85% R.H., Condenser water in/out 30/35°C

Heating A7W55: Evaporator air in 7°C, 85% R.H., Condenser water in/out 47/55°C

Cooling A35W18: Condenser air in 35°C. Evaporator water in/out 23/18°C

Cooling A35W7: Condenser air in 35°C. Evaporator water in/out 12/7°C

Indoor unit: 240 model + Outdoor unit: 12kW

Heating A7W35

A B C D

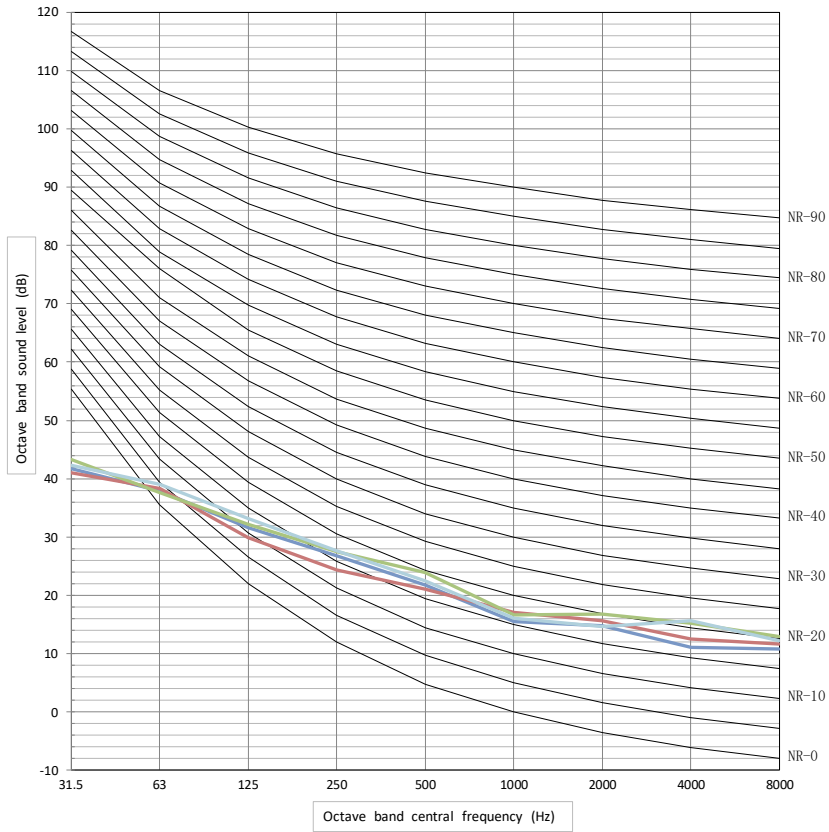

Heating A7W55

A B C D

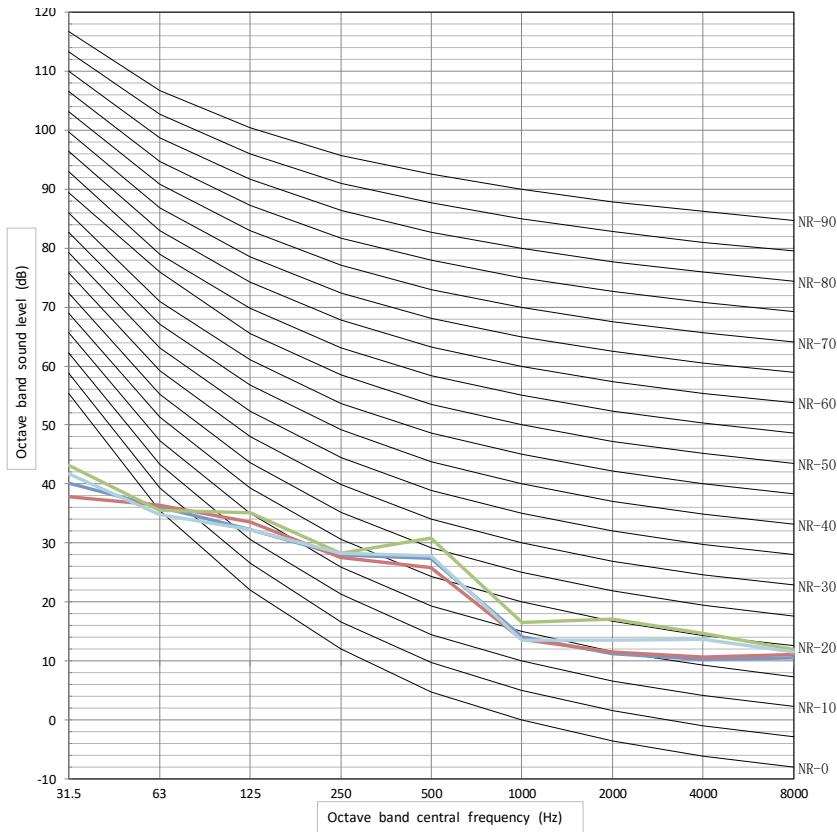

Cooling A35W18

A B C D

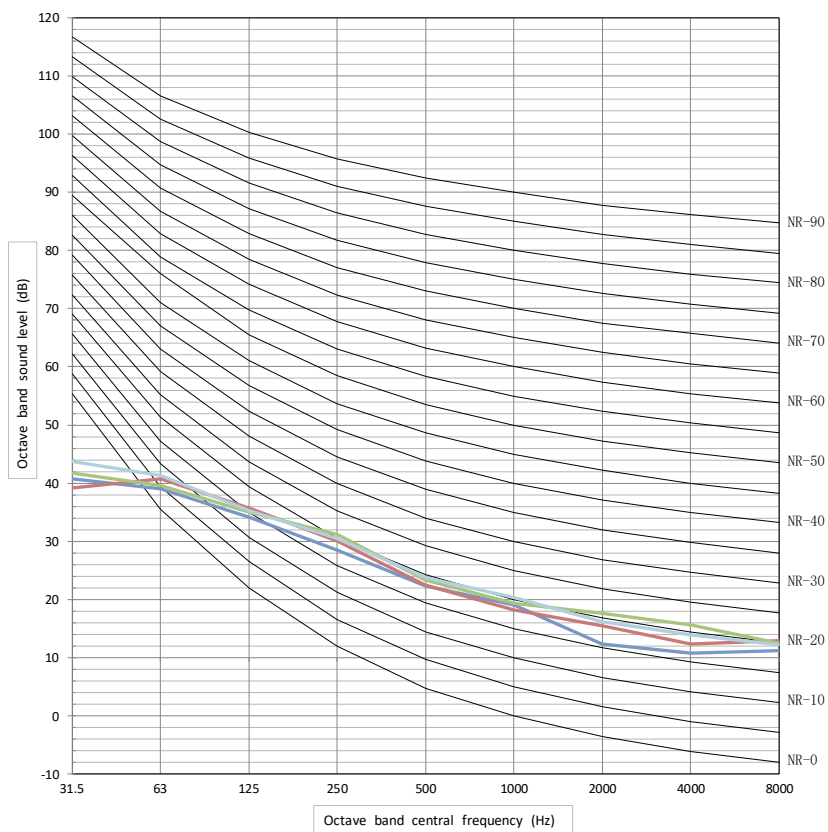

Cooling A35W7

A B C D

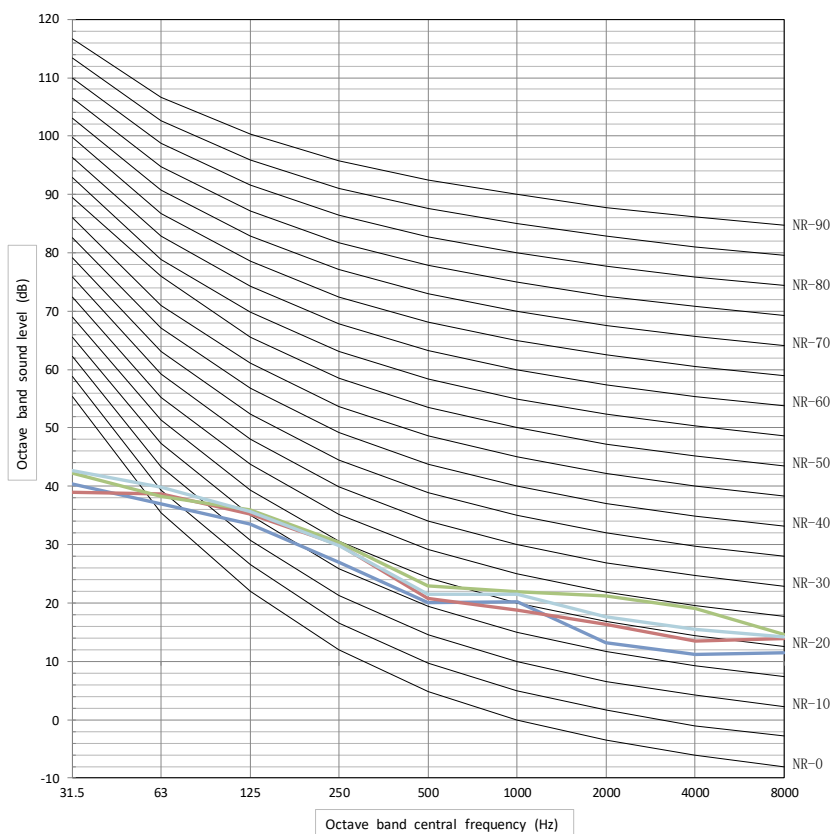

Indoor unit: 240 model + Outdoor unit: 14kW

Heating A7W35

— A — B — C — D

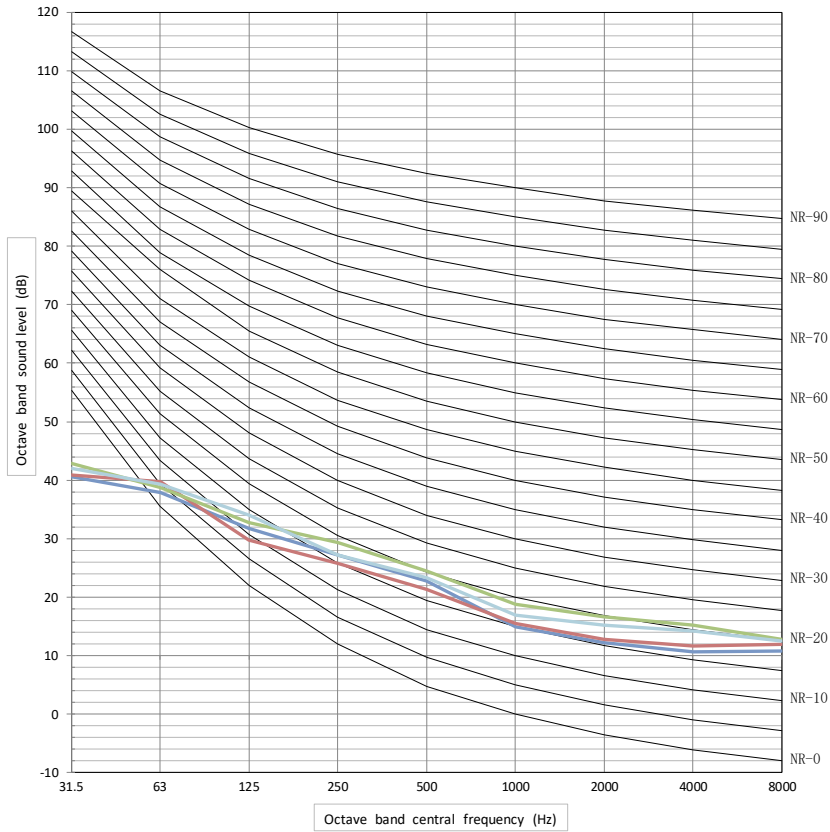

Heating A7W55

— A — B — C — D

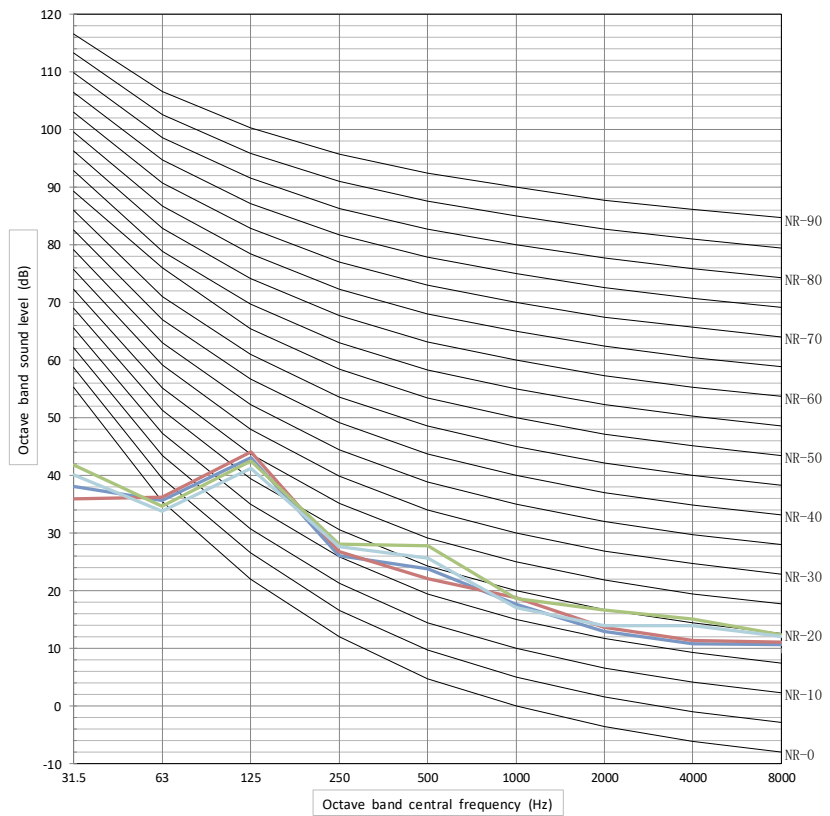

Cooling A35W18

A B C D

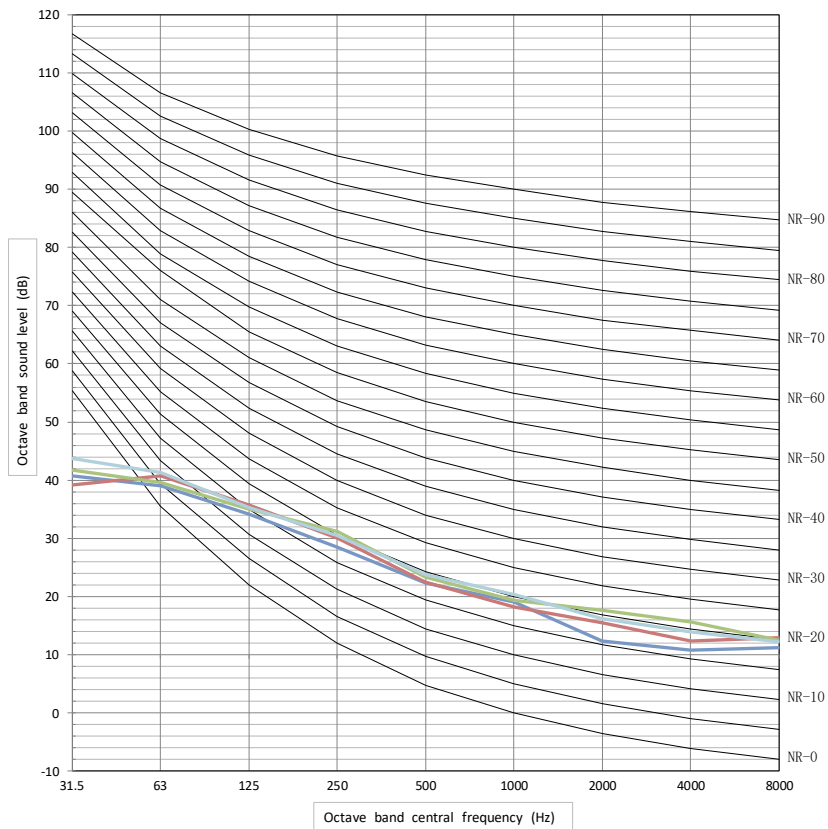

Cooling A35W7

A B C D

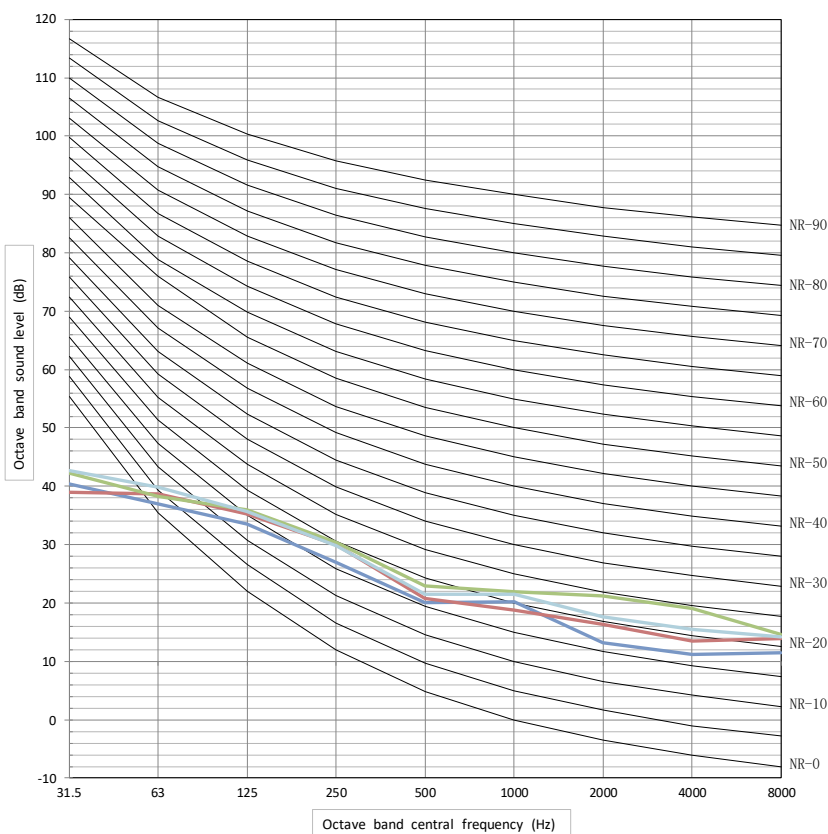

Indoor unit: 240 model + Outdoor unit: 16kW

Heating A7W35

A B C D

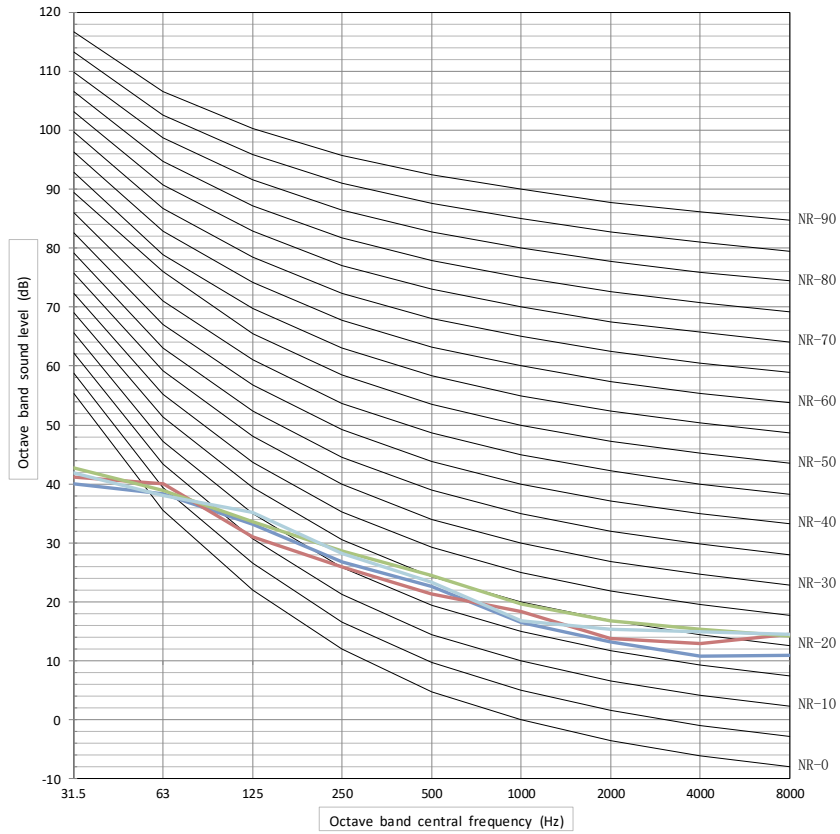

Heating A7W55

A B C D

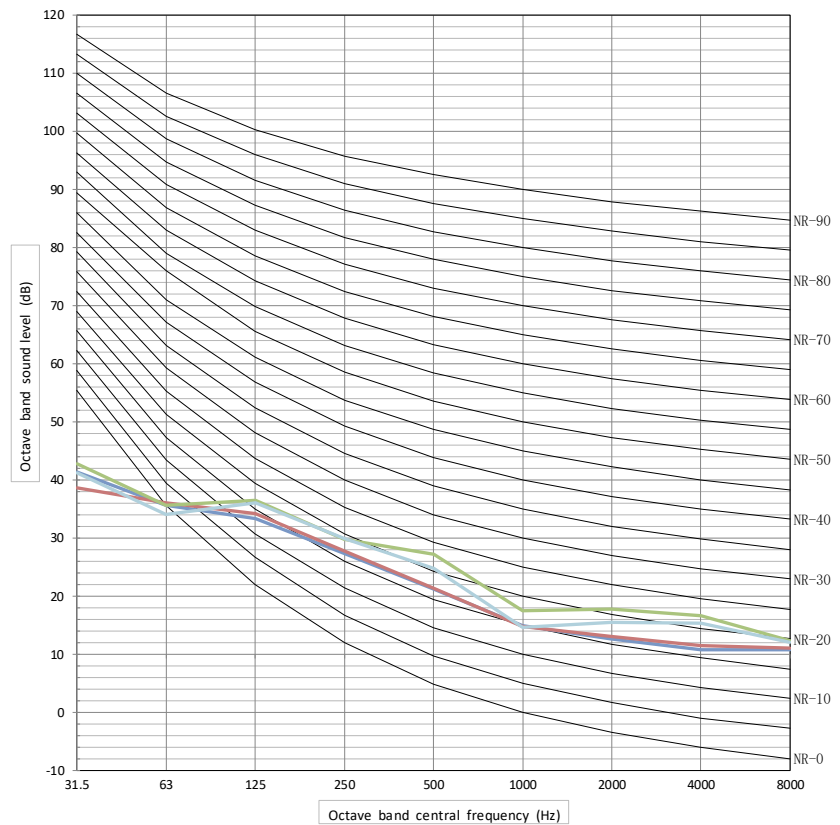

Cooling A35W18

A B C D

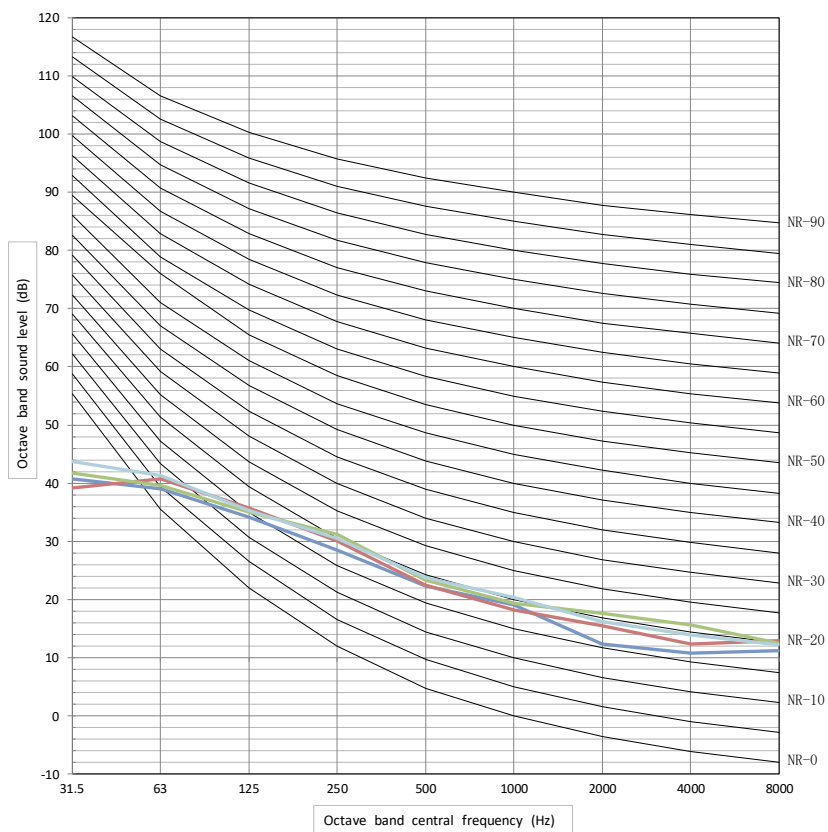

Cooling A35W7

A B C D

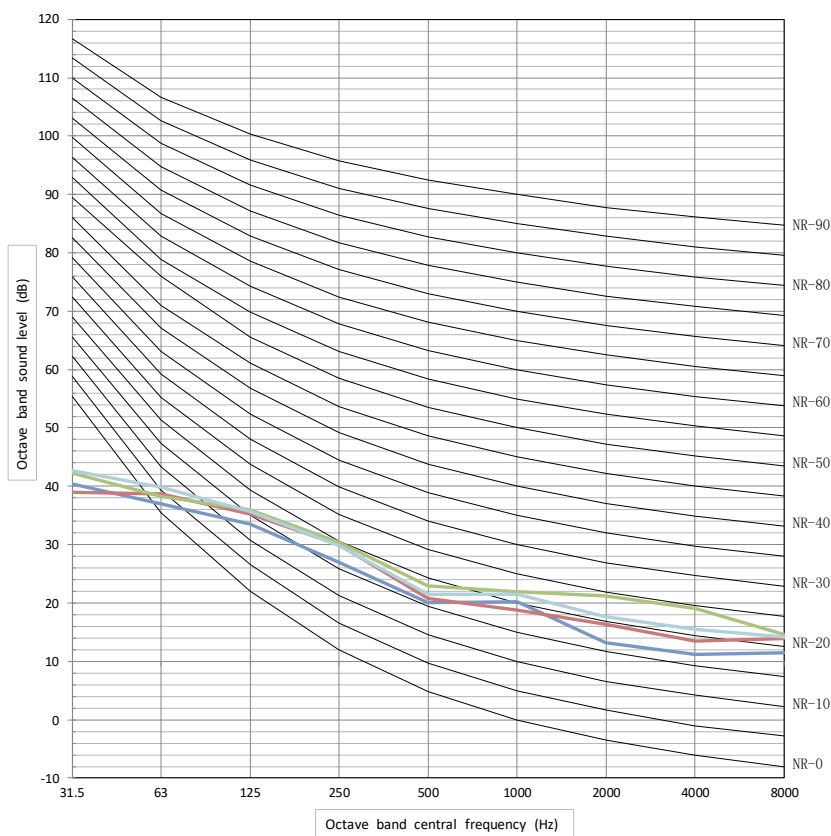

Midea Building Technologies Division
Midea Group

Address: Midea Headquarters Building, 6 Midea Avenue, Shunde, Foshan, Guangdong, China

Postal code: 528311







mbt.midea.com / global.midea.com

Midea reserves the right to change the specifications of the product, and to withdraw or replace products without prior notification or public announcement. Midea is constantly developing and improving its products.

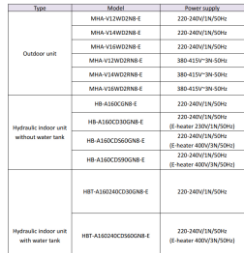
Please note that all pictures in the document are for reference only. Actual products may vary.

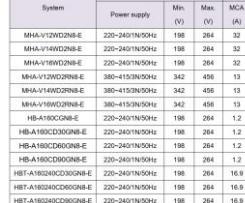

Manual Update Record

Previous version	New version	Screenshot after revision	Revised page no.	Revised content	Reviser	Revision time
Ver. 2024-11	Ver. 2025-9		P7	Add indoors with E-heater	Susan	2025/9/12
Ver. 2024-11	Ver. 2025-9		P12-16	Add indoors with E-heater	Susan	2025/9/12
Ver. 2024-11	Ver. 2025-9		P21	Add indoors with E-heater	Susan	2025/9/12
Ver. 2025-9	Ver. 2026-02		P73	Add manual update record	Susan	2026/2/24
Ver. 2026-02	Ver. 2026-03		P17-18	Correct Sound pressure Level (1m/2m/3m)	Susan	2026/3/26
Ver. 2026-02	Ver. 2026-03		P29-37	Update heating capacity tables	Susan	2026/3/26