

Installation Guide

Expansion Module 3 (EM3)

For Thermia Atlas and Calibra models



Thermia AB is not liable or bound by warranty if these instructions are not adhered to during installation or service.

The English language is used for the original instructions.
Other languages are a translation of the original instructions.
(Directive 2006/42/EC)

© Copyright Thermia AB

Table of Contents

1	Important information/Safety instructions	4
	1.1 Safety precautions	4
	1.2 About the document	4
2	Installation	5
	2.1 Delivery content	5
	2.2 Internal installation	5
3	Supported functions	8
	3.1 Supported functions	8
	3.2 Function ID:0, Domestic	11
4	Wiring diagram	42
	4.1 Table item number	42
	4.2 Wiring diagram	45

1 Important information/Safety instructions

1.1 Safety precautions

Danger

Hazardous electrical voltage! The terminal blocks are live and may cause death through electric shock. All power supplies must be isolated before electrical installation is started.

Warning

Before making any electrical work, turn off the power supply connected to the heat pump.

Warning

Electrical installation may only be carried out by an authorized electrician and must follow applicable local and national regulations (IEC 60335-2-40).

Warning

Risk of personal injury! Children are not permitted to play with the product.

1.2 About the document

This manual is only intended for professional and trained installers and electricians with prior experience in installing heat pumps & accessories. Industrial standards, common branch practice and local regulations must always be followed, even if not explicitly stated in this document.

2 Installation

2.1 Delivery content

Included in delivery:

Item	Pcs.
EM3 card	1
Power supply cable	1
Modbus communication cable	1
PCB spacers	8
PCB grounding screws	2
Installation manual	1
Self adhesive wiring diagram	1

2.2 Internal installation

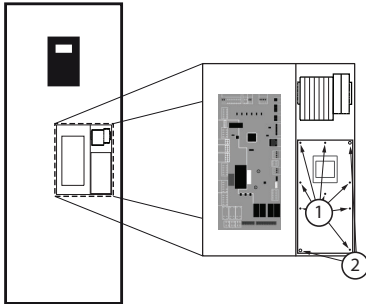

1. PCB spacers. Put in place before mounting the EM3 card.
2. PCB grounding screw. Screw in place after mounting the EM3 card on the spacers.

Make sure that the function switch in the center of the EM3-card is set to the 0 (default) position and that the jumper next to it is set to open position (jumper is NOT mounted on both pins).

Function switch

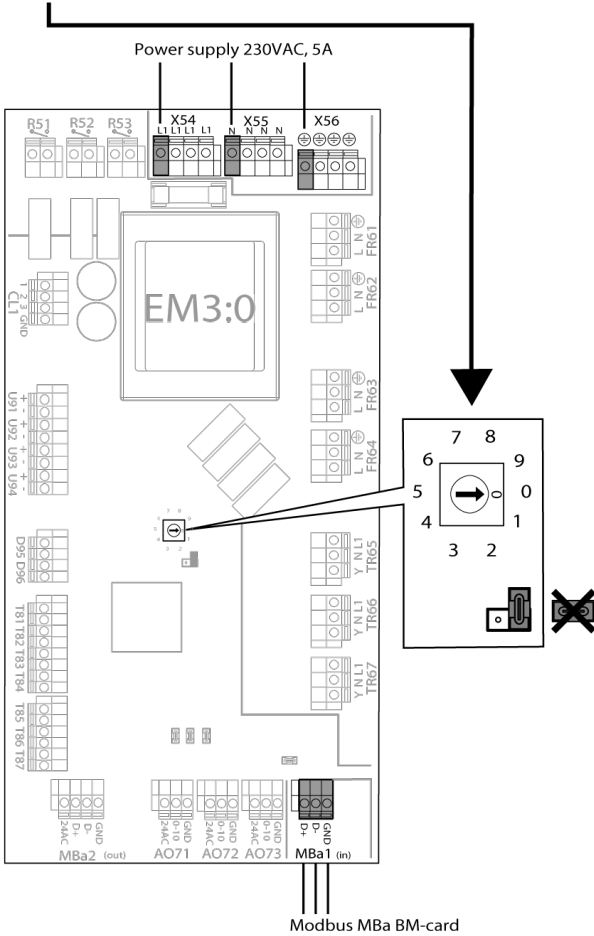

Installation Guide

Expansion Module 3 (EM3)

IMPORTANT! Make sure that main power supply to the heat pump is off before installing EM3!

Disconnect the incoming main power to the BM card by removing Y510 socket.

Connect the power cables from the BM-card (Y510 socket, L1 230 IN) to the **X54, X55 and X56** terminals on the EM3-card using the included cable and reconnect the incoming power cables to the branched socket, as shown in the picture below.

Continue by connecting the Modbus cables to the **MBa1** terminals, see picture below.

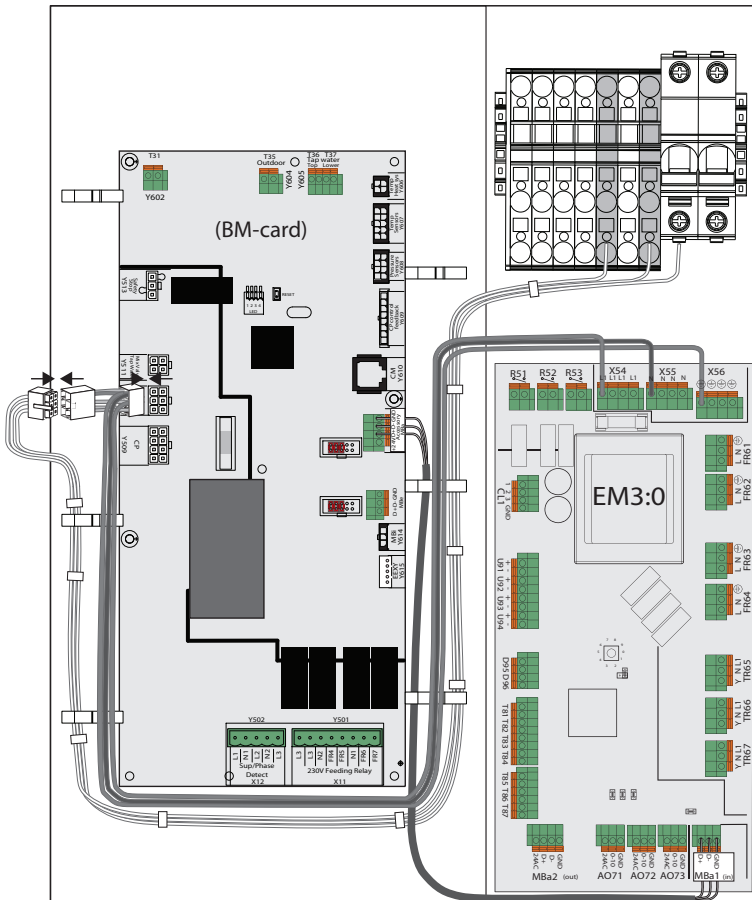

3 Supported functions

3.1 Supported functions

This expansion module and the descriptions in this document is intended only for the use with Thermia Atlas and Calibra models with software 10.01 and above. The table below gives a quick overview of which functions that works with each heat pump using EM3. See the respective chapter for further details.

Function	Atlas	Comments for Atlas functionality	Calibra models	Comments for Calibra functionality
Distribution circuit 1 (former "heat curve 2")	No	Standard on BM-card	Yes	
Pool heating	Yes		Yes	
Passive cooling	Yes		(Yes)	Function not supported for heat pumps with inbuilt cooling
Active cooling without cooling tank	Yes		(Yes)	Function not supported for heat pumps with inbuilt cooling
External brine pump control (ground water pump)	Yes		Yes	
Internal brine pump start	(Yes)	Internal brine pump start and Flow guard share the same terminal on the BM-card. If both functions are needed, EM3 is required.	(Yes)	Internal brine pump start and Flow guard share the same terminal on the BM-card. If both functions are needed, EM3 is required. Available on the BM-card from software 9.0 and January 2020. If not available use EM3. Flow guard on EM3 is not supported for heat pumps with inbuilt cooling.
Flow guard	(Yes)		(Yes)	
Smart grid/EVU	No	Standard on BM-card	(Yes)	Available on the BM-card from software 9.0 and January 2020. If not available use EM3.
Buffer tank	No	Standard on BM-card	(Yes)	Function not supported for heat pumps with inbuilt cooling
External auxiliary heater	(Yes)	External auxiliary heater and Sum alarm share the same terminal on the BM-card. If both functions are needed, EM3 is required for Sum alarm.	Yes	
Sum alarm (output)	(Yes)		Yes	
External alarm (input)	Yes		Yes	
Current limiter	Yes	Requires toroidal transformer accessory 086U2793	Yes	Requires toroidal transformer accessory 086U2793

Function	Atlas	Comments for Atlas functionality	Calibra models	Comments for Calibra functionality
System circulation pump	No	Standard on BM-card	Yes	
System supply line sensor	No	Standard on BM-card	Yes	

Technical information:

- Only compatible with Atlas and Calibra models. (Not compatible with Diplomat Inverter M or Diplomat Inverter L). Diplomat Inverter Mini is also technically compatible, but requires external cabinet and, on site customized cable extensions, as there is no space for EM3 inside the electrical cabinet.
- Only one EM3 expansion card may be installed per installation
- Temperature sensor type: PT1000 (not included)
- 0-10V control for e.g. mixing valve control
- 24V AC inbuilt transformer for supply to mixing valves*
- 230V supply to reversing valves and circulation pumps*
- Potential free relays* (with terminals to enable e.g. 230V supply)
- Input by open/closed loop (digital in)
- Output by open/closed loop (relay)

* Max load on 230V feeding relays (marked "FR..") or potential free relays (marked "R..") is 230W with normal motors. Max 850W with soft starting loads.

Max total load on EM3 is 5A.

Max load on TRIAC output (marked "TR") = 10VA

Total max load on 24V supply to supply mixing valve actuators: 21VA

IMPORTANT! Requires Genesis software version 8.0 or later (this document and its instructions are based on Genesis software version 10.01). Please note that a restart of the control system is required for the installation to establish communication between the heat pump and the Expansion module (There is only need to restart once, regardless of number of functions added at the same time). This is indicated by the following icon in the display top bar (the same symbol is used in "Operating mode" in the display to execute a restart):



Glossary for abbreviations printed on the EM-card:

- **X:** Power supply (in and out, 230VAC)
- **R:** Potential free relay
- **FR:** Feeding relay (230VAC)
- **TR:** TRIAC output (230VAC)
- **MBa1:** ModBus communication in
- **MBa2:** Modbus communication out
- **AO:** Analogue out
- **CL:** Current limiter
- **U:** Universal input (analogue/digital)
- **D:** Digital input

- **T:** Temperature sensor input (PT1000)
- **Funktions ID:** ID selector
- **MBa TERM:** Termination jumper

Suggested accessories:

- Temperature sensor PT1000: 086L4466 PT-1000 2m
- Reversing valves (including actuator): 086U7999 LK 230V (22 & 28mm)
- Mixing valve actuators: 086U5272 ESBE ARA659 P 24V 45/120s 0-10V
- Mixing valve housings: 086U5265 3-way mixing valve VRG131 DN20-KVS 6,3
- Mixing valve housings: 086U5266 3-way mixing valve VRG131 DN25-KVS 10
- Torodial transformers (for current limiter): 086U2793
- Circulation pumps: 230V circulation pump max 230W

Installation Guide

Expansion Module 3 (EM3)

3.2 Function ID:0, Domestic

3.2.1 Distribution circuit 1

Function availability:

Heat pump platform	Available functionality with EM3:0	Comments
Atlas	No	Standard in Atlas heat pump (Connect to BM-card)
Calibra	Yes	

In heating systems where there is a need of a separately controlled heating circuit (in addition to the open main circuit) with a lower heat curve, it is possible to control a separate circuit (mixing valve, temperature sensor and circulation pump) with a lower set heat curve.

The supply line temperature for distribution circuit 1 is determined from the Temperature sensor (108), and is used to regulate the mixing valve actuator (107). The circulation pump (109) is running when the heat pump is in heating season.

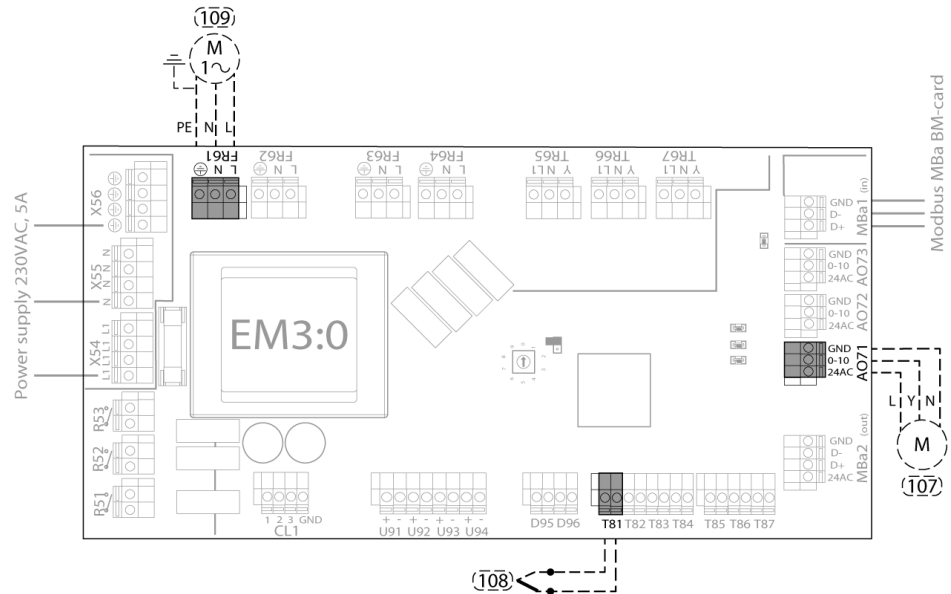
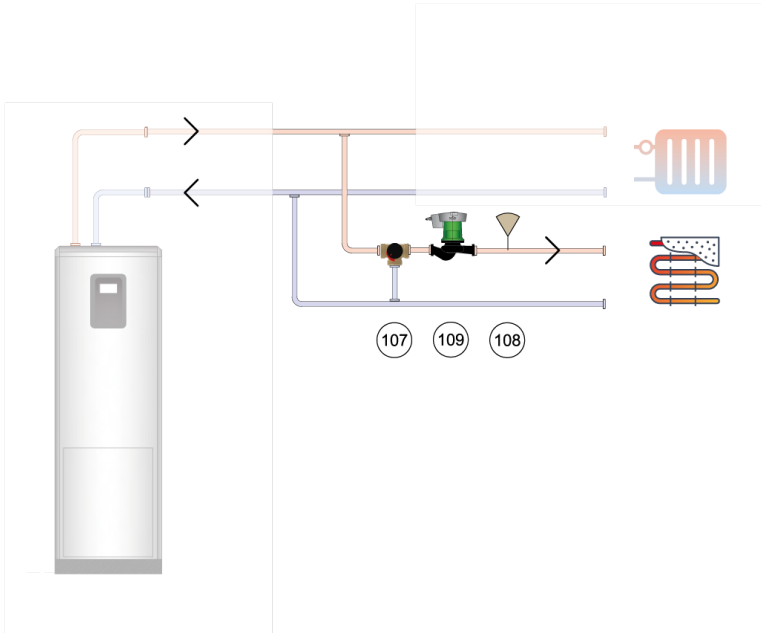



Table item number	Terminal	Description
107	AO71	Shunt (distribution circuit 1)
108	T81	Supply line sensor (distribution circuit 1)
109	FR61	Circulation pump (distribution circuit 1)



Commissioning after installation:

1. Login: Press padlock, 607080 and confirm
2. Go to SETTINGS/INSTALLATION, navigate to Distribution circuit 1, select  and press 
3. Go to SETTINGS/MIX VALVES/DISTRIBUTION CIRCUIT 1 and turn on function
4. Make desired settings and save
5. Restart the heat pump and check functionality

3.2.2 Pool

Function availability:

Heat pump platform	Available functionality with EM3:0	Comments
Atlas	Yes	
Calibra	Yes	

The purpose of this function is to control and maintain a constant temperature for swimming pool or similar.

The heat pump will determine the need for pool heating by the pool return line sensor (60). When the pool heating starts, the reversing valve (101) will direct the flow towards the pool heat exchanger and the heat pump will then produce pool heating. Pool heating will stop when the temperature read value has increased with the pool hysteresis value (or when the pool time is exceeded).

Required connections:

- 230V reversing valve
- PT-1000 temp sensor pool return temp is used for pool control
- Pool equipment (e.g. heat exchanger, pumps etc.)

Optional accessories:

- PT1000 temp sensor for pool supply (183). Not used for control, only a read value in the display
- Optional external "pool off" function (342), controlled via digital input from e.g. circuit breaker (normally open)

Settings description:

Desired pool return temperature: Target (median) temperature from pool return sensor.

Pool hysteresis: Total permitted deviation for start/stop heating (offset from desired pool temperature.)

Desired charge temp: Target temperature for heat pump supply line. (Calculation/selection of compressor speed is based on heat pump supply line temperature.)

Compressor max/min gear: Compressor speed range permitted for pool, may be used to optimize performance.

Pool time: Max pool time when other conflicting demands arises (such as heating/hot water demands), in heating season max 3,5 hours.

Gear shift delay: Delay time for changing compressor speed.

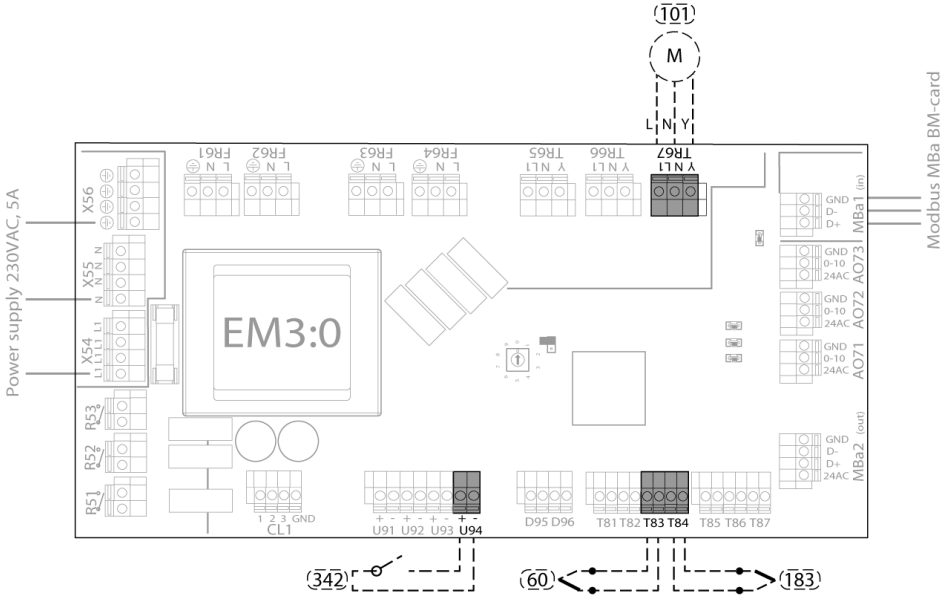
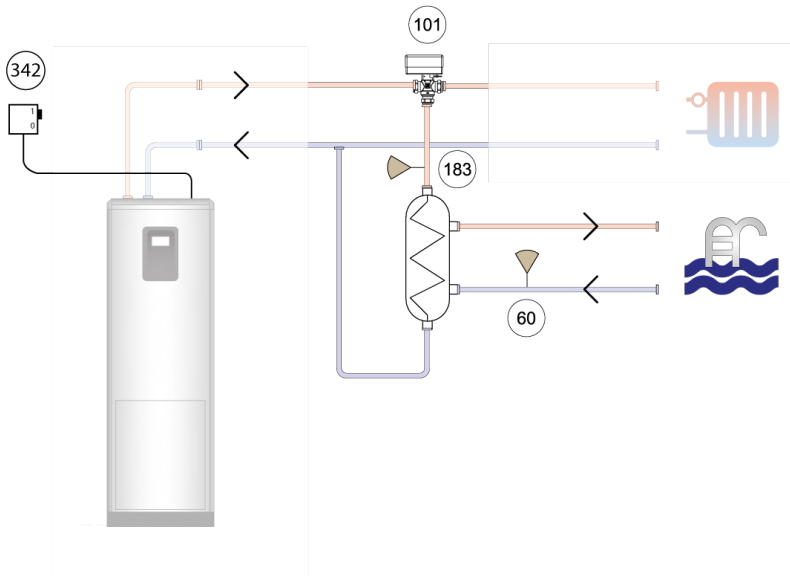

Table item number	Terminal	Description
60	T83	Sensor pool
101	TR67	Pool heating valve
183	T84	Supply line sensor pool (optional)
342	U94	External pool off (optional)



Commission after installation:

1. Login: Press padlock, 607080 and confirm
2. Go to SETTINGS/INSTALLATION, navigate to Pool, select and press ✓
3. Go to SETTINGS/POOL and turn on function
4. Make desired settings and save
5. Restart the heat pump and check functionality

3.2.3 Passive cooling

Function availability:

Heat pump platform	Available functionality with EM3:0	Comments
Atlas	Yes	
Calibra	Yes	Function not supported for heat pumps with inbuilt cooling

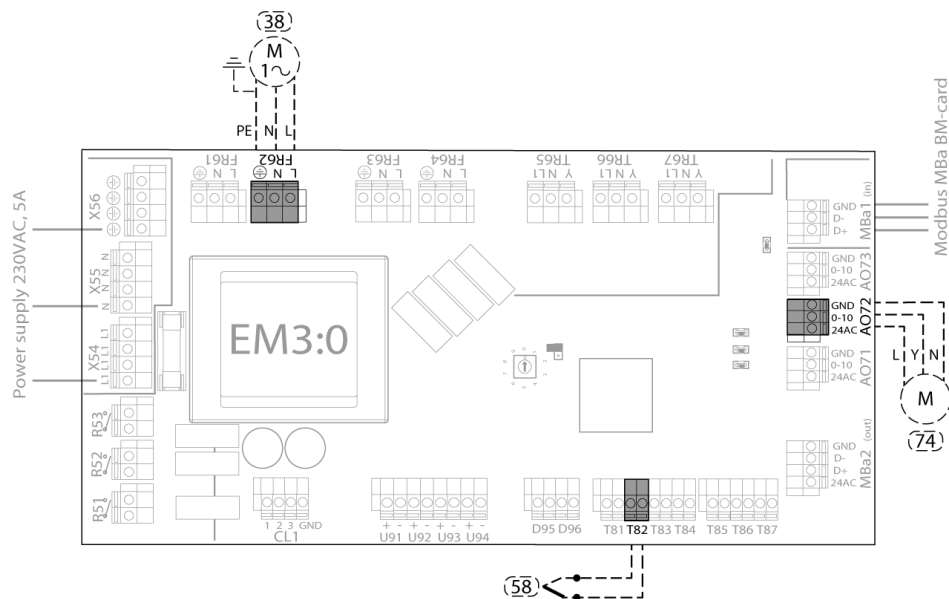

Table item number	Terminal	Description
38	FR62	Circulation pump (cooling circuit)
58	T82	Supply line sensor cooling circuit
74	AO72	Shunt valve cooling circuit

With the Passive cooling function, it is possible to produce a very energy efficient passive cooling by circulating the brine to a separate circuit (with or without intermediate heat exchanger). A requirement to make passive cooling useful is that the brine temperatures are not too high. When Passive cooling is desired due to e.g. high outdoor temperatures, leading to high indoor temperatures, it is possible to control and regulate a separate circuit to a fixed cooling temperature set point with EM3 consisting of:

- Cooling circulation pump (38)
- Shunt valve cooling circuit (74)

- Cooling supply line temperature sensor (58)
- (Optional heat exchanger)

The temperature reading from the supply line sensor cooling circuit (58) is used for regulating the shunt valve cooling circuit (74) (mixing valve). The mixing valve and cooling circuit circulation pump (38) is active when the heat pump is in cooling season (which is determined by the cooling integral and settings made for seasonal cooling start) in the controller and a cooling demand is detected.

When cooling is produced, the internal brine pump and the cooling circulation pump is running. The mixing valve will strive to keep desired cooling supply line temperature to the set value (desired cooling temp) in the controller.

Passive cooling starts when the cooling season starts. If room sensor for cooling is enabled the room temperature also needs to be above the desired room temperature + **passive cooling room sensor offset**. (Modbus type room sensor can be connected to MBa2 terminal).

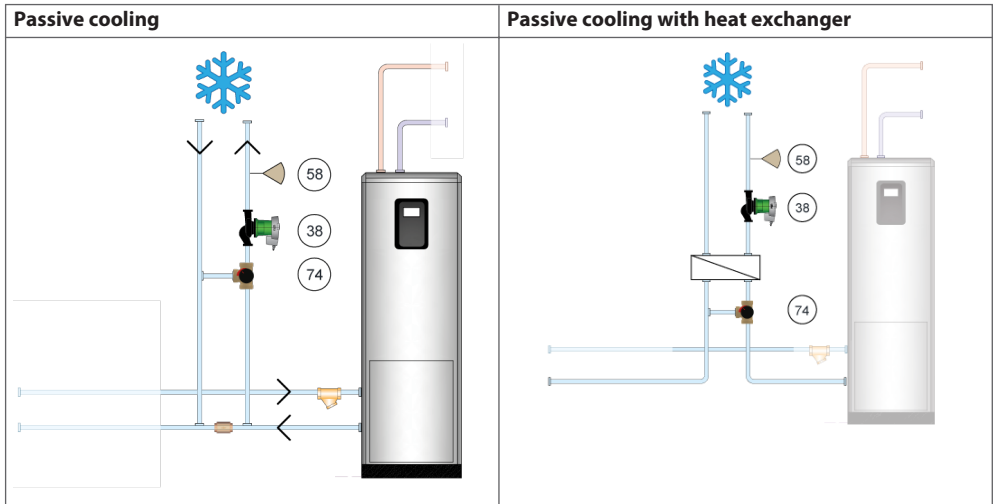

Pictures above are showing system solutions where the passive cooling is connected after the heat pump, to utilize the free "active" cooling when the heat pump is running due to other demands. If the extra cooling effect is not desired (e.g. to get a more constant brine temperature/regulation) the system solution must be modified (not described in this manual).

Commissioning after installation:

1. Login: Press padlock, 607080 and confirm
2. Go to SETTINGS/INSTALLATION, navigate to Cooling and select EM3 and press 
3. Go to SETTINGS/COOLING and turn on Passive cooling function

4. Make desired settings, e.g.
 Seasonal cooling temp = what outdoor temperature the seasonal cooling integral shall count on
 Desired cooling temp = set target for the regulation of cooling supply line
5. Restart heat pump and check functionality

3.2.4 Passive/active cooling

Function availability:

Heat pump platform	Available functionality with EM3:0	Comments
Atlas	Yes	
Calibra	Yes	Function not supported for heat pumps with inbuilt cooling

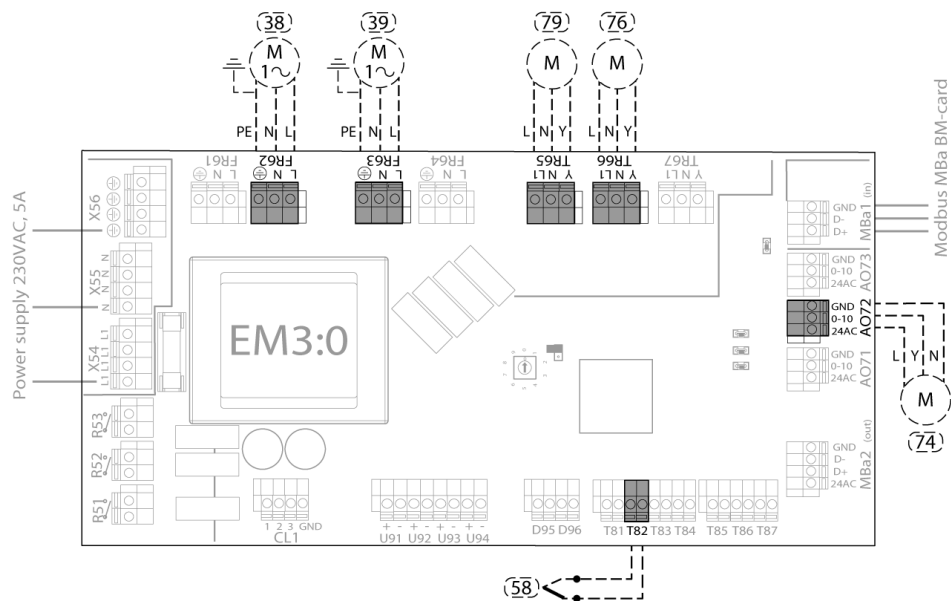
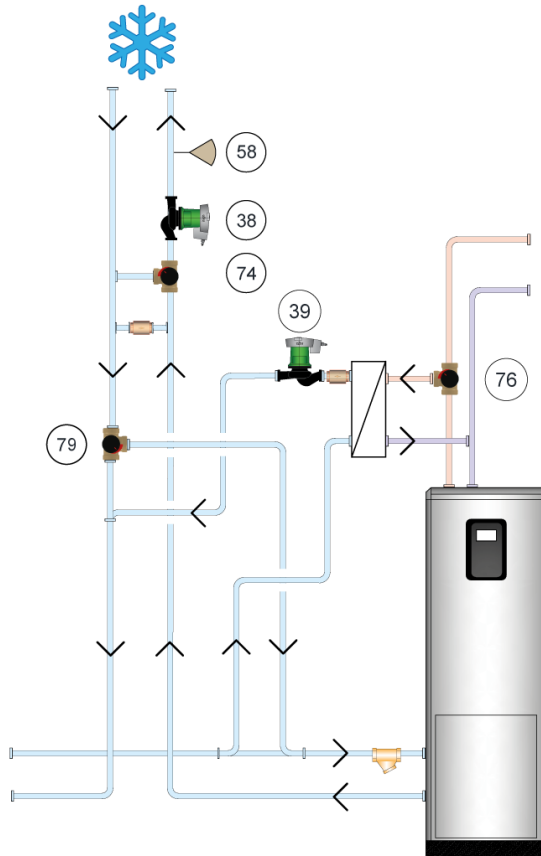

Table item number	Terminal	Description
38	FR62	Circulation pump (cooling circuit)
39	FR63	Circulation pump (heat dump)
58	T82	Supply line sensor cooling circuit
74	AO72	Shunt valve cooling circuit
76	TR66	Reversing valve heat dump
79	TR65	Reversing valve active cooling

With the Passive / active cooling function, the heat pump can control and produce passive cooling when the brine temperatures are sufficiently low, but also actively use the compressor to produce active cooling (and dump excess heat to brine if no other heat demand is active).



When Passive/active cooling is desired due to e.g. high outdoor temperatures, leading to high indoor temperatures, it is possible to control and regulate a separate circuit to a fixed cooling temperature set point with EM3 consisting of:

- Cooling circulation pump
- Shunt valve cooling circuit
- Cooling supply line temperature sensor
- Circulation pump for heat dump
- Reversing valve heat dump

- Reversing valve active cooling
- (heat exchangers)



The temperature reading from the supply line sensor cooling circuit (58) is used for regulating the shunt valve cooling circuit (74) (mixing valve). The mixing valve and cooling circuit circulation pump (38) is active when the heat pump is in cooling season (which is determined by the cooling integral and settings made for seasonal cooling start) in the controller and a cooling demand is detected. When the passive cooling is not sufficient, active cooling will start.

When cooling is produced, the internal brine pump is running and the cooling circulation pump is running. The mixing valve will strive to keep desired cooling supply line temperature to the set value (desired cooling temp) in the controller. When active cooling is produced, the heat dump circulation pump and reversing valve will be engaged.

Passive cooling: Passive cooling starts when the cooling season starts. If room sensor for cooling is enabled the room temperature also needs to be above the desired room temperature + **passive cooling room sensor offset**. (Modbus type room sensor can be connected to MBa2 terminal).

Active cooling: Active cooling starts when the cooling supply line temperature exceeds the start temp. cooling setting. If room sensor for cooling is enabled, active cooling will only start if the room temperature is above the desired room temperature + **active cooling room sensor offset**.

Commissioning after installation:

1. Login: Press padlock, 607080 and confirm
2. Go to SETTINGS/INSTALLATION, navigate to Cooling, select  EM3  and press 
3. Go to SETTINGS/COOLING and enable passive cooling AND active cooling
4. Make desired settings, e.g.
Seasonal cooling temp = what outdoor temperature the seasonal cooling integral shall count on
Desired cooling temp = set target for the regulation of cooling supply line temperature
5. Restart the heat pump and check functionality

Installation Guide

Expansion Module 3 (EM3)

3.2.5 External brine pump

Function availability:

Heat pump platform	Available functionality with EM3:0	Comments
Atlas	Yes	
Calibra	Yes	

In applications where an external brine pump or ground water pump needs to be controlled, this can be done with EM3:0. The external signal (230V on/off) is active when the internal brine pump is active. If continuous operation of the brine pump is activated, the external brine pump also operates continuously.

The relay is potential free, so if 230V signal is desired, connect one relay input to X54 and use X55 for Neutral and X56 for PE connection.

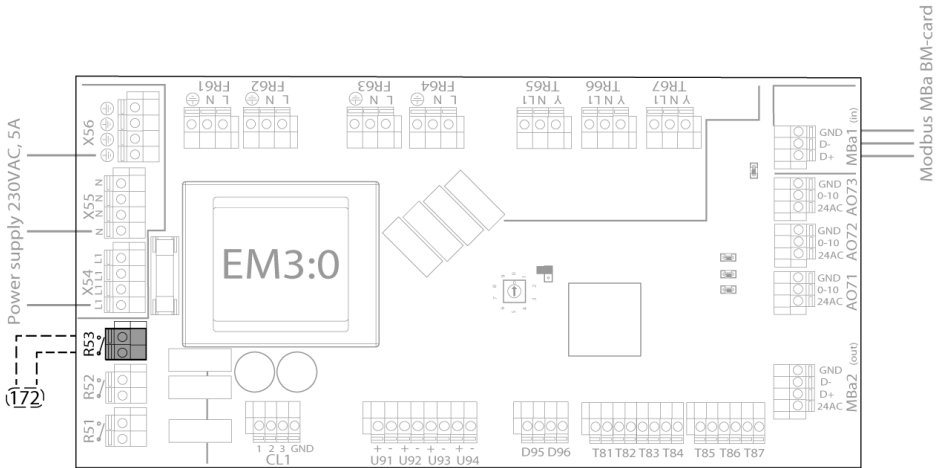
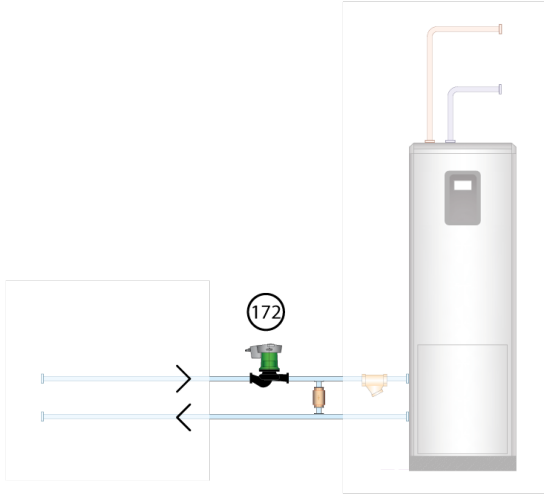



Table item number	Terminal	Description
172	R53	Auxiliary circ. pump (brine)



Commissioning after installation:

1. Login: press padlock, 607080 and confirm
2. Go to SETTINGS/INSTALLATION, navigate to External brine pump (no separate menu for activation exists in sw 8.0), select and press 
3. Restart the heat pump and check functionality.

Installation Guide

Expansion Module 3 (EM3)

3.2.6 Internal brine pump on external signal

Function availability:

Heat pump platform	Available functionality with EM3:0	Comments
Atlas	(Yes)	Internal brine pump on external signal is standard on the BM-card but share the same terminal as Flow guard. If both functions are used one of them has to be connected to the EM3-card.
Calibra	(Yes)	For Calibra: Standard on the BM-card from software 9.0 and January 2020. If not available use EM3. Function not supported on BM-card for heat pumps with inbuilt cooling.

In applications where e.g. cooling is achieved by a separate system, (not controlled by the heat pump) the internal brine pump can be activated on external command using EM3:0. The digital in (Open/closed loop) is then activating the internal brine pump when required. The internal brine pump will run when the control signal loop is closed.

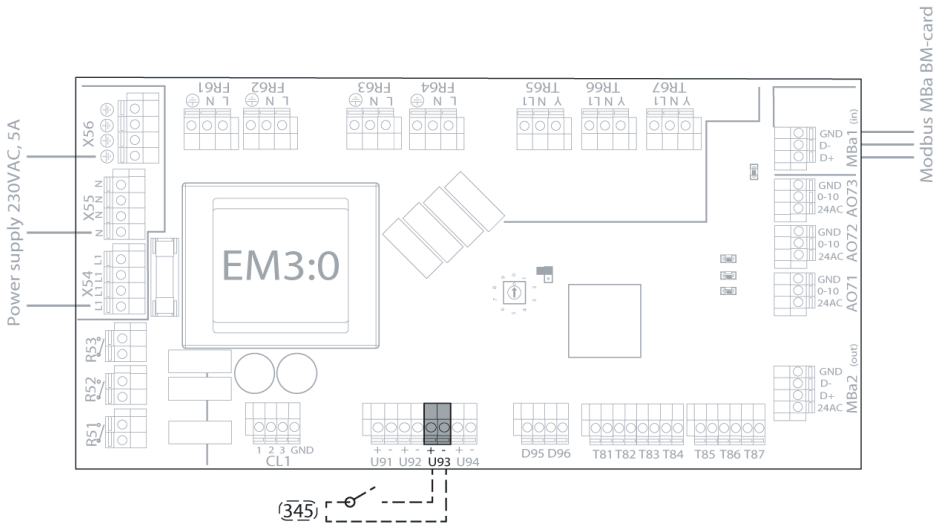



Table item number	Terminal	Description
345	U93	Start internal brine

Commissioning after installation:

1. Login: press padlock, 607080 and confirm
2. Go to SETTINGS/INSTALLATION, navigate to External brine pump (no separate menu for activation exists in sw 8.0), select and press 
3. Restart the heat pump and check functionality.

Installation Guide

Expansion Module 3 (EM3)

3.2.7 Flow guard/pressure switch

Function availability:

Heat pump platform	Available functionality with EM3:0	Comments
Atlas	(Yes)	Flow guard/pressure switch is standard on the BM-card, but share the same terminal as Internal brine pump on external signal. If both functions are used one of them has to be connected to the EM3-card.
Calibra	(Yes)	For Calibra: Standard on the BM-card from software 9.0 and January 2020. If not available use EM3. Function not supported on EM3 for heat pumps with inbuilt cooling.

In applications where a flow guard or pressure switch is required to stop or prevent starting the compressor in the case of a lack of flow or pressure, this can be installed with EM3 and monitored with a digital input (open / closed loop. Flow = Closing)

Normal Flow guard functionality:

Flow sensor monitoring is active when the internal/external brine pump is running, or the compressor is running. During the start sequence, the flow sensor has default 25 seconds (start delay compressor - 5 seconds) to report flow. If the flow disappears while the compressor is in operation, the compressor will stop directly. If there is a loss of flow an alarm is triggered immediately, but a restart attempt may be permitted. When a restart attempt is activated, an alarm is triggered if the flow disappears more than three times in two hours. Time between stop and start is 20 minutes (not restriction time).

The flow sensor alarm prevents the brine pump from running until the alarm has been acknowledged. This blocks passive cooling.

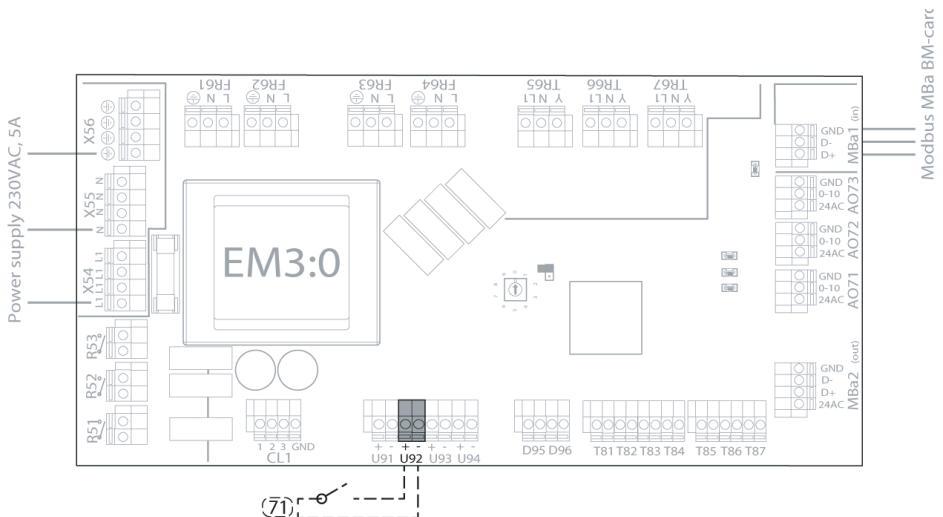
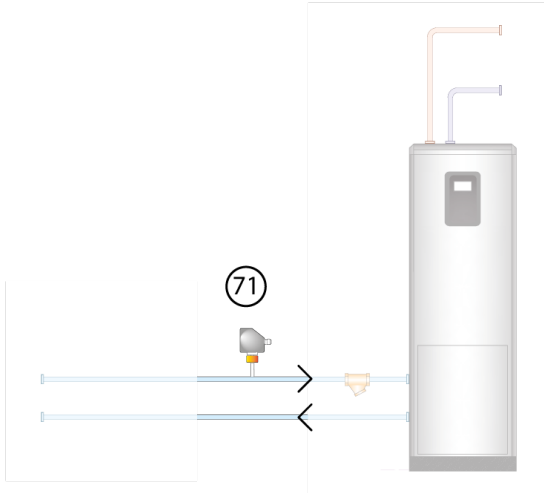

Table item number	Terminal	Description
71	U92	Flow guard



Commissioning after installation:

1. Login: 607080
2. Go to SETTINGS/INSTALLATION, navigate to Flow guard, select and press ✓
3. Go to SETTINGS/FLOW GUARD and turn on Flow/pressure switch
4. Make desired settings and confirm
5. Restart heat pump and check functionality

3.2.8 Smartgrid/EVU

Function availability:

Heat pump platform	Available functionality with EM3:0	Comments
Atlas	No	Standard in Atlas heat pump (connect to BM-card)
Calibra	(Yes)	Standard on the BM-card from software 9.0 and January 2020. If not available use EM3.

Smart grid/EVU consists of two digital inputs which gives four different combinations including normal operation. (EVU, Normal, Comfort and Boost)

SG-1	SG-2	(closing=1)
0	0	Normal: Normal operation
0	1	Comfort: Increased start and stop temperature of hot water (default 45°C and 60°C). The wheel is replaced internally in the software with "Desired room temperature - Comfort" (default 22°C).
1	0	EVU: The function blocks compressor operation and internal immersion heater. Other components such as circulation pumps, exchange valves and external auxiliary heater are still controlled.
1	1	Boost: Increased start and stop temperature of hot water, increased room setting (default 22°C) and triggers anti-legionella if the tank is two degrees below stop temperature for anti-legionella. Buffer tank: sets desired tank temperature to 55°C, and if "Allow immersion heater during boost" is set in GUI, internal immersion heater is also used.

Note: The EVU functionality will prevent the compressor from starting. If the compressor is running, trigger of the EVU signal will cause a compressor stop to be initiated. Note that the compressor will need up to 5 minutes to stop depending, on running circumstances. Physical power cut off, before the compressor has stopped, is not permitted, as repeated cut off power supply when the compressor is running, could cause operational disturbances/damage.

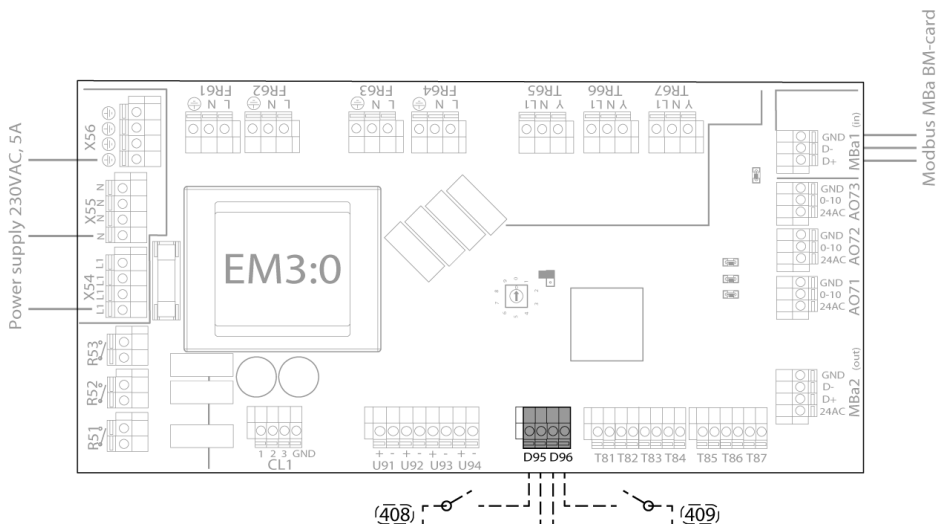

Table item number	Terminal	Description
408	D95	EVU/Smart grid 1
409	D96	Smart grid 2

1. Login: press padlock, 607080 and confirm
2. Go to SETTINGS/INSTALLATION, navigate to Smart grid, select and press
3. Go to SETTINGS/SMARTGRID and turn on function
4. Make desired settings and save
5. Restart the heat pump and check functionality

3.2.9 Buffer tank

Function availability:

Heat pump platform	Available functionality with EM3:0	Comments
Atlas	No	Standard in Atlas heat pump (connect to BM-card)
Calibra	(Yes)	Function not supported for heat pumps with inbuilt cooling

There are three different setups of buffer tank. All three enables connection of different heat sources (such as wood, solar heating or waist heating) to be connected to the same accumulator tank as the heat pump, and will make it possible for the heat pump and other sources of non-controllable heat to work together.

Installation Guide

Expansion Module 3 (EM3)

(Please note that if a mixing valve controlled by the heat pump is not fitted (= tank is to be used only as a volume tank), buffer tank control should not be activated.)

Alt 1: Heat pump physically connected to charge buffer tank (without external auxiliary heater controlled by heat pump).

With this setup the heat pump will charge the tank, meaning that heating will be supplied from the tank to the heating system.

As the heat pump in this application is charging the tank and always has the water volume of the hot water tank to work with, it is often possible to achieve long running time for the compressor with few stops also when the heat demand is low. The heat pump will use the buffer tank sensor (136) and the system supply line sensor (51) to regulate the buffer tank (aux heater shunt) (72) and heat pump. The shunt will then control on the calculated set point from the main curve, using the system supply line sensor to calculate the heat demand. The system circulation pump (36) is required and running when the heat pump is in heating season.

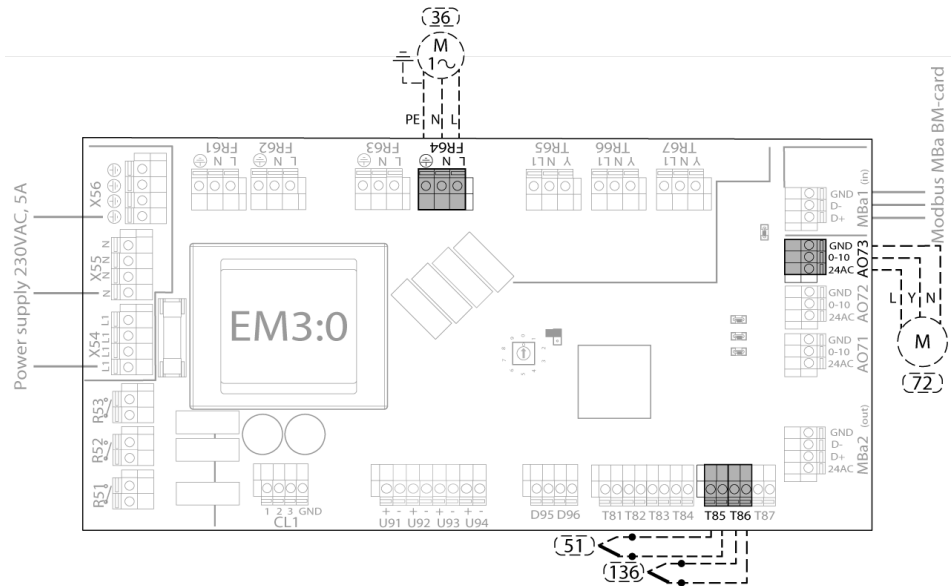
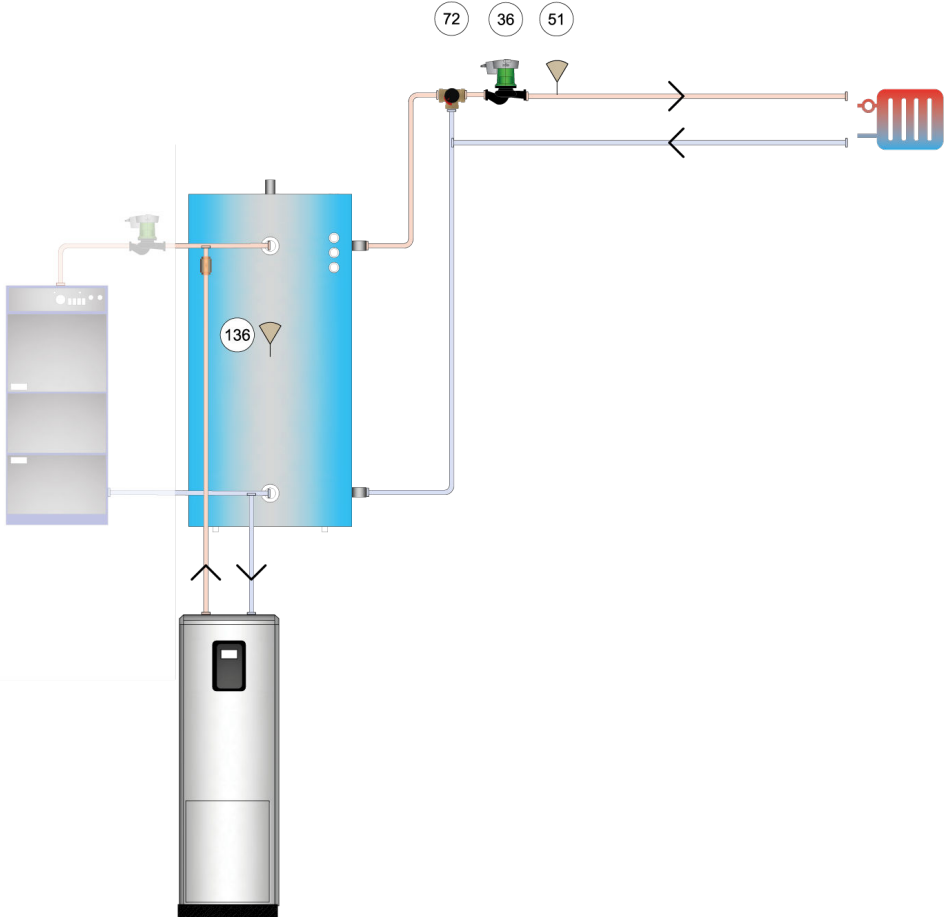

Table item number	Terminal	Description
36	FR64	Circulation pump (system)
51	T85	System supply line sensor
72	AO73	External auxiliary heater shunt (used as buffer tank shunt)
136	T86	Buffer tank sensor



Commissioning after installation:

1. Login: Press padlock, 607080 and confirm
2. Go to SETTINGS/INSTALLATION, navigate to Buffer tank, select and press ✓
3. Go to SETTINGS/BUFFER TANK, activate buffer tank shunt control & select
4. Go to SETTINGS/CIRCULATION PUMPS. Enable system circulation pump.
5. Make other desired settings and save
6. Restart heat pump and check functionality

Alt 2: Heat pump **NOT** connected to charge tank (not in combination with external aux heater)

With this setup, the heat pump is never charging the tank ("heat pump connected to tank" should be "off" in the controller menu), but when the tank temperature, measured by buffer tank sensor (136), exceeds set over-charge temperature above desired supply line temp, the compressor will stop and the buffer tank shunt / Aux heater shunt (72) will regulate the shunt according to set heat curve and use the energy in the tank before the heat pump is started again. When the temperature in the buffer tank is colder than the system set point, the system shunt is completely switched off and the compressor starts based on the demand calculation as usual.

This alternative does not use the volume available in the tank to achieve longer running time but may be preferred in certain applications where it is not desired to charge the accumulator tank. This solution requires a system circulation pump.

The function requires a system pump and is not supporting external auxiliary heater controlled by heat pump or Pool functionality.

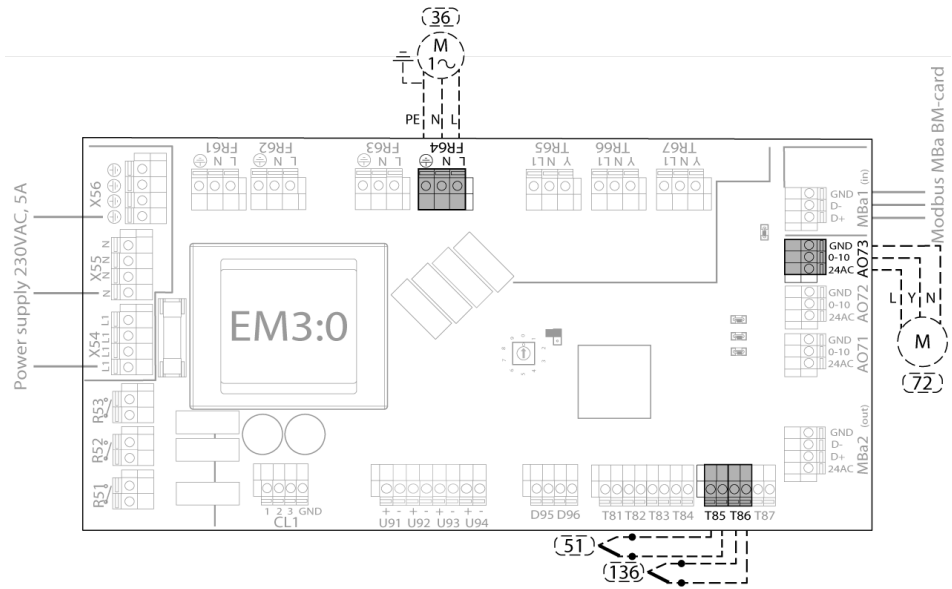
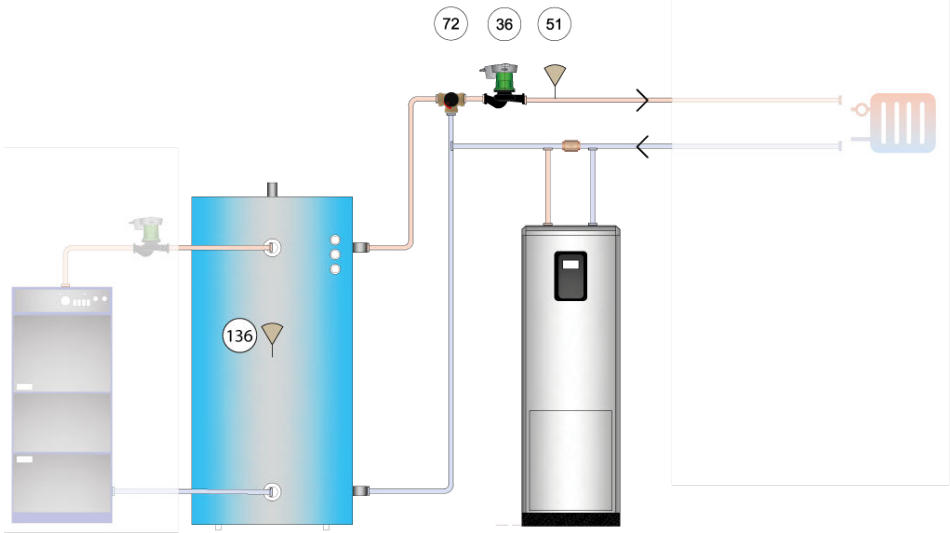

Table item number	Terminal	Description
36	FR64	Circulation pump (system)
51	T85	System supply line sensor
72	AO73	External auxiliary heater shunt (used as buffer tank shunt)
136	T86	Buffer tank sensor



Commissioning after installation:

1. Login: Press padlock, 607080 and confirm
2. Go to SETTINGS/INSTALLATION, navigate to Buffer tank, select and press ✓
3. Go to SETTINGS/BUFFER TANK, activate buffer tank shunt control & select
4. Go to SETTINGS/CIRCULATION PUMPS. Enable system circulation pump.
5. Make other desired settings and save
6. Restart heat pump and check functionality

Alt 3: Heat pump physically connected to charge buffer tank & external auxiliary heater controlled by heat pump.

This is a customized (non-standard) solution where both internal and external auxiliary heater can be controlled by the heat pump.

A special note is that in this case the electrical connections should be done somewhat differently to the other alternatives as 2 shunts / heaters (0-10V) will need to be controlled.

The aux heater & aux heater circulation pump will in this case be connected to the aux heater shunt and the buffer tank shunt & circulation pump to the system will be connected to the output for distribution circuit 1. The auxiliary heater must be connected to the buffer tank according to system solution presented below. (External auxiliary heater cannot be located after the buffer tank out to the heating system.)

Installation Guide

Expansion Module 3 (EM3)

Heat settings: Note that the heat curve for supply to the heating system in this customized case is set in the distribution circuit 1 menu (=not set in the normal heat curve menu) and that activation of distribution circuit 1 in the Installation menu is required, but that the regulation of buffer tank temperatures is made from the settings made in the main curve + buffer tank menu.

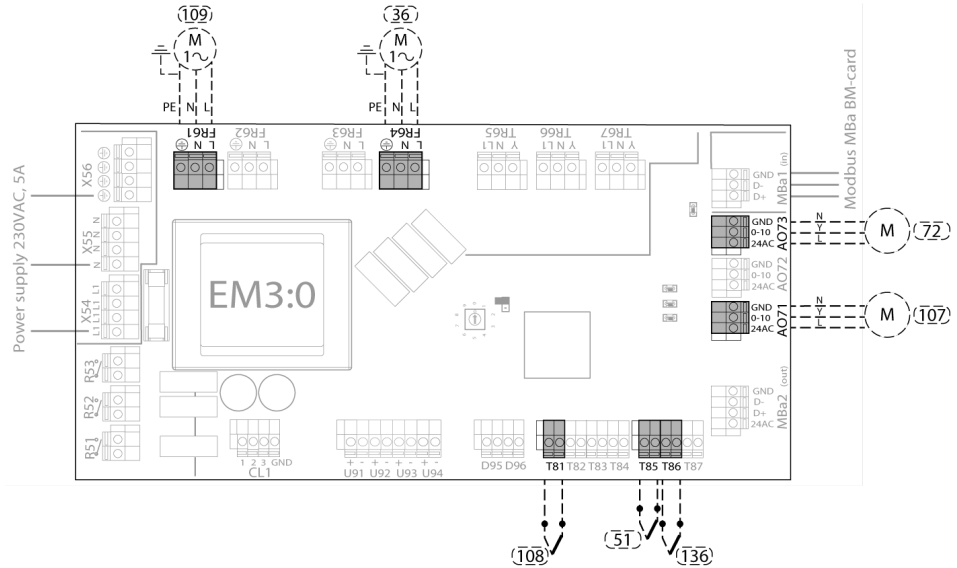
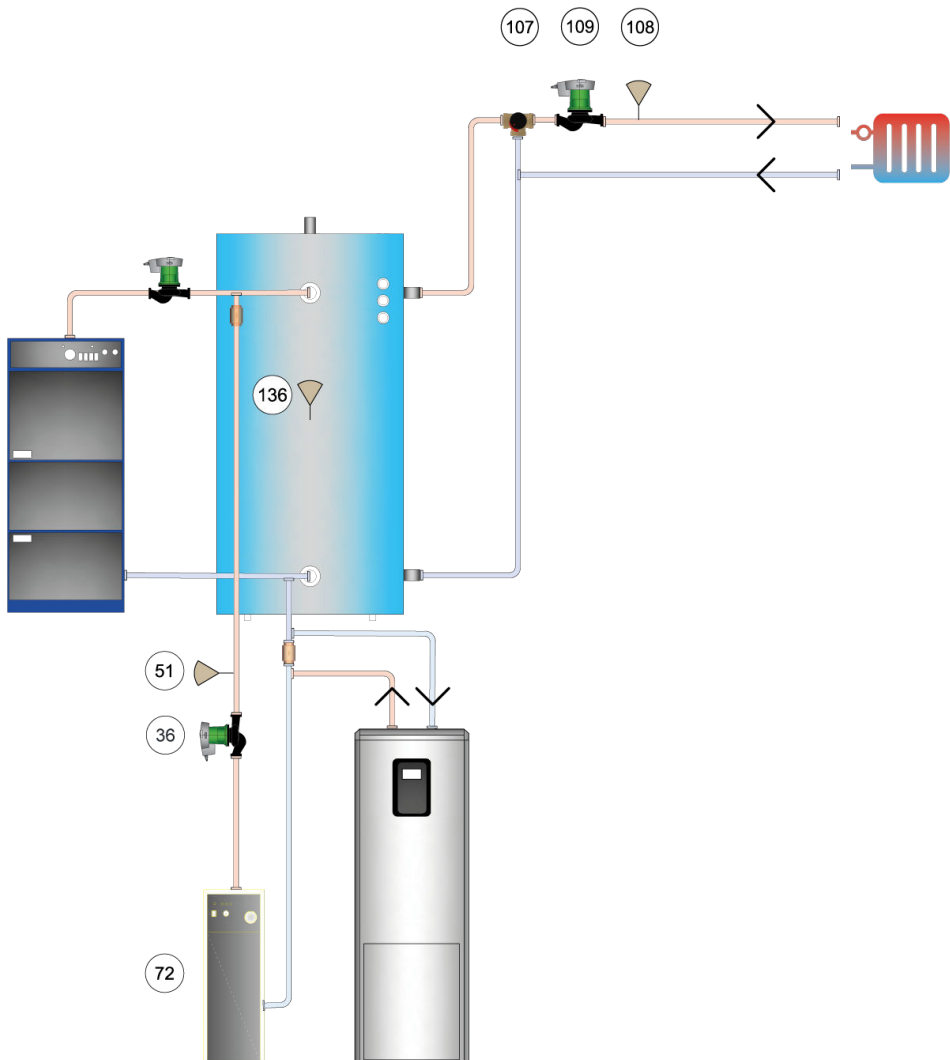

Table item number	Terminal	Description	In this application used for:
36	FR64	Circulation pump (system)	Aux. heater
51	T85	System supply line sensor	Aux. heater
72	AO73	External auxiliary heater shunt	Aux. heater
107	AO71	Shunt (distribution circuit 1)	Heat distribution
108	T81	Supply line sensor (distribution circuit 1)	Heat distribution
109	FR61	Circulation pump (distribution circuit 1)	Heat distribution
136	T86	Buffer tank sensor	Buffer tank sensor



Commissioning after installation:

1. Login: press padlock, 607080 and confirm.
2. Go to SETTINGS / INSTALLATION, navigate to Buffer tank, select and press ✓
3. Go to SETTINGS / INSTALLATION, navigate to External auxiliary heater, select and press ✓
4. Go to SETTINGS / INSTALLATION, navigate to Distribution circuit 1, select and press ✓
5. Go to SETTINGS/ BUFFER TANK. Select . Make other desired settings and confirm.
6. Go to SETTINGS/ EXTERNAL AUX HEATER. Activate external auxiliary heater. Make other desired settings and confirm.
7. Go to SETTINGS/ Distribution circuit 1. Activate Distribution circuit 1 for "heat" (default). Make other desired settings and confirm.
8. Go to SETTINGS/CIRCULATION PUMPS. Enable system circulation pump.
9. Adjust main heat curve according to desired buffer tank temperature target.
10. Adjust Distribution circuit 1 according to heat requirement (not higher than main heat curve settings)
11. Restart the heat pump and check functionality

3.2.10 External auxiliary heater

Function availability:

Heat pump platform	Available functionality with EM3:0	Comments
Atlas	No*	Standard in Atlas heat pump (connect to BM-card)
Calibra	Yes	

* External auxiliary heater is standard in Atlas heat pumps, but share the same terminal on the BM-card as Sum alarm. If both functions are used, Sum alarm has to be connected to the EM3-card, as External auxiliary heater can only be connected to the BM-card.

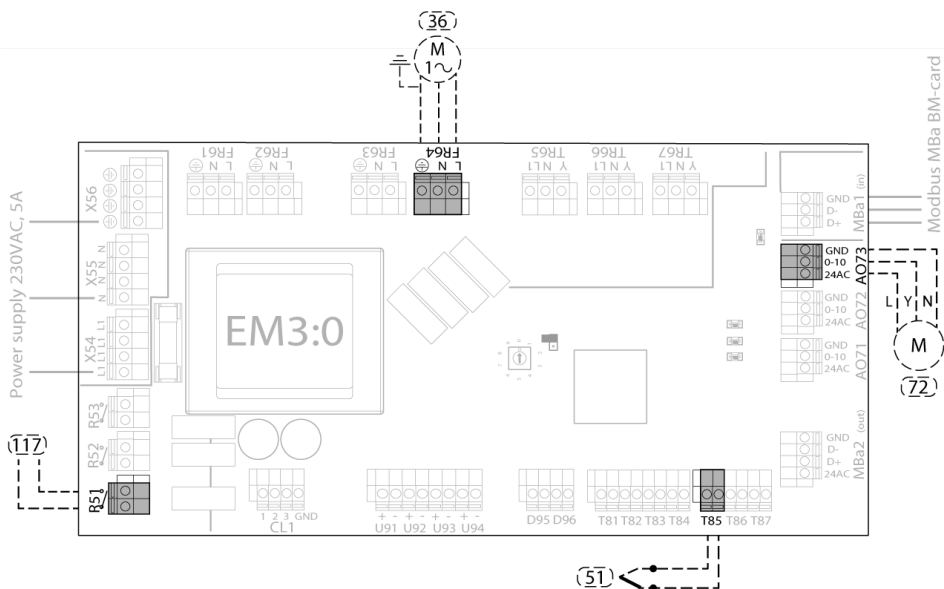
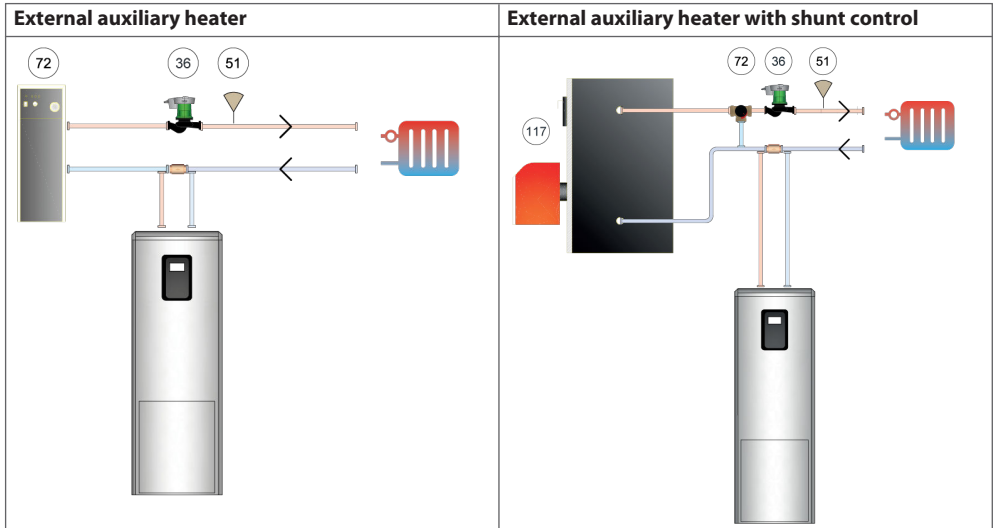

Table item number	Terminal	Description
36	FR64	Circulation pump (system)
51	T85	System supply line sensor
72	A073	External auxiliary heater shunt
117	R51	External auxiliary heater



The heat pump can, in addition to heat pump and internal immersion heater also control external aux heater (0-10V and on/off). The external auxiliary heater requires a system supply line sensor.

The external auxiliary heater also controls a 0-10 V signal which regulates system supply line temperature in accordance with calculated set point and desired delay.

The relay (117) is potential free, so if 230V signal is desired, connect one relay input to X54 and use X55 for Neutral and X56 for PE connection.

External auxiliary heater can only produce heating and pool (if pool after external auxiliary heater is activated).

1. Login: Press padlock, 607080 and confirm
2. Go to SETTINGS/INSTALLATION, navigate to Auxiliary heater, select EM3 and press 
3. Go to SETTINGS/AUXILIARY HEATER and turn on function
4. Go to SETTINGS/CIRCULATION PUMPS. Enable system circulation pump.
5. Make desired settings and save
6. Restart heat pump and check functionality

3.2.11 Sum alarm (output)

Function availability:

Heat pump platform	Available functionality with EM3:0	Comments
Atlas	(Yes)*	Standard in Atlas heat pump (connect to BM-card)
Calibra	Yes	



* Sum alarm is standard in Atlas heat pumps, but share the same terminal on the BM-card as External auxiliary heater. If both functions are used, Sum alarm has to be connected to the EM3-card as External auxiliary heater can only be connected to the BM-card.

With the sum alarm function, it is possible to make alarms trigger a relay output signal that can be connected to for example a strobe light.

It is possible to set the alarm level that shall activate the signal in 3 levels:
 Alarms class A+B+C (= all alarms)
 Alarms Class A+B (=only alarms that may affect function etc.)
 Alarms Class A (=only alarms that stops compressor etc.)

For connection, see wiring diagram "Alarm relay" (position number 344). Relay is potential free, so if 230V signal is desired, connect one relay input to X54 and use X55 and X56 for supply.

Commissioning after installation:

1. Login: press padlock, 607080 and confirm
2. Go to SETTINGS/INSTALLATION, navigate to Sum alarm, select  and press 
3. Go to SETTINGS/ALARM CONTROL/SUM ALARM. Activate Sum alarm by selecting desired alarm level to trigger the external signal. Confirm.
4. Restart the heat pump and check functionality

3.2.12 External alarm (input)



Function availability:

Heat pump platform	Available functionality with EM3:0	Comments
Atlas	Yes	
Calibra	Yes	

With the external alarm (input) function it is possible for the heat pump to detect and inform about alarms from external sources via the heat pump display when active and Online. External alarms are treated as level C alarms (notification/automatic reset) and will not stop the heat pump.

For connection, see wiring diagram "External Alarm" (position number 444). Digital input (open/closed loop).

Commissioning after installation:

1. Login: press padlock, 607080 and confirm
2. Go to SETTINGS/INSTALLATION, navigate to External alarm, select  EM3  and press 
3. Go to SETTINGS/ALARM CONTROL/EXTERNAL ALARM. Activate External alarm.
4. Restart the heat pump and check functionality

3.2.13 Current limiter

Function availability:



Heat pump platform	Available functionality with EM3:0	Comments
Atlas	Yes	Requires toroidal transformers (accessory)
Calibra	Yes	Requires toroidal transformers (accessory)

With the Current limiter function it is possible for the heat pump to monitor the current drawn in an installation in order to for example protect the main fuses. The heat pump will measure 3 phases with the toroidal transformer (separate accessory, not included in EM3 delivery) that are installed in the place where the current should be monitored.

The aux heater will step down when one of the phases measured value exceeds set max phase current. Step up is depending on the setting of hysteresis. Also compressor RPM can be reduced if required.

Install the toroidal transformers where the current shall be measured and connect to EM3 as per wiring diagram (see Current Limiter, position 456)

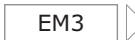
Commissioning after installation:

1. Login: press padlock, 607080 and confirm.
2. Go to SETTINGS/INSTALLATION, navigate to Current limiter, select  and press .
3. Go to SETTINGS/CURRENT LIMITER, enable Current limiter, make desired settings and confirm.
4. Restart the heat pump and check functionality.

3.2.14 System circulation pump & system supply line sensor

Function availability:

Heat pump platform	Available functionality with EM3:0	Comments
Atlas	No	Standard in Atlas heat pumps (connect to BM-card)
Calibra	Yes*	

In certain systems (such as systems with a volume tank where there is no shunt valve) it may be desired to let the heat pump control a system pump (circulation pump for heating) and make the heat pump calculate the demand based on the system supply line sensor that can be positioned after the volume tank. To do this (provided that no other function uses these connections), install according to wiring diagram (position number 51 & 36) and enable "system pump" in the circulation pump menu, then go to SETTINGS/INSTALLATION and activate Auxiliary heater or Buffer tank, in order to establish a connection. There is no need to activate the functions in their respective settings view for the system to communicate.

3.2.15 Connection of additional Modbus accessories

In cases where additional Modbus accessories (such as room sensor) should be installed, an extra connection for Modbus accessories is available on EM3. See wiring diagram ("MBA2 (out)"). Note that activation of connected accessory & restart of the controller in the menu is required to establish communication. See installation manual for the connected accessory.

4 Wiring diagram

4.1 Table item number

The following number/note are used for the heat pump. Which number/note are used depends on the heat pump model.

Number/Note	Description
31	Circulation pump (HWC)
32	Circulation pump (pool)
33	Circulation pump (shunt auxiliary heater)
34	Circulation pump (hot gas)
35	Circulation pump (WCS)
36	Circulation pump (system)
38	Circulation pump (cooling circuit)
39	Circulation pump (heat dump)
40	Expansion card
48	External brine in sensor
49	External brine out sensor
50	Outdoor sensor
51	System supply line sensor
52	System return line sensor
53	Hot water sensor lower
54	Sensor (WCS)
55	Hot water sensor top
56	Sensor HWC return line
57	Return line sensor cooling tank
58	Supply line sensor cooling circuit
59	Sensor cooling tank
60	Sensor pool
61	Return line sensor heat dump
62	Room sensor
63	Sensor hot water
64	Sensor cold water
71	Flow guard

Number/Note	Description
72	External auxiliary heater shunt
73	Control valve WCS
74	Shunt valve cooling circuit
75	Mixing valve HW
76	Reversing valve heat dump
77	Reversing valve hot water
78	Reversing valve cooling
79	Reversing valve active cooling
101	Reversing valve pool
107	Shunt (distribution circuit 1)
108	Supply line sensor (distribution circuit 1)
109	Circulation pump (distribution circuit 1)
115	Auxiliary heater hot gas boiler
117	External auxiliary heater
118	Auxiliary heater (anti-legionella)
119	Control signal dry cooler
132	Passive room sensor
136	Buffer tank sensor
143	Return line shunt
170	System circ. pump A
171	System circ. pump B
172	Auxiliary circ. pump (brine)
173	BMS/Building management system
174	Accessory
175	Accessory monitoring online
176	External heater burn out pump

Installation Guide

Expansion Module 3 (EM3)

Number/Note	Description
180	Tank sensor TWC (hot gas boiler)
181	Return line sensor (cooling circuit)
182	Supply line sensor heat dump
183	Supply line sensor pool
184	Reversing valve hot gas boiler
185	Reversing valve cooling mode
186	Reversing valve individual pool
207	Shunt (distribution circuit 2-5)
208	Supply line sensor (distribution circuit 2-5)
209	Circulation pump (distribution circuit 2-5)
210	Return line sensor (distribution circuit 2-5)
250	Shunt pool circuit
251	Shunt valve heat dump
301	Compressor
302	Brine pump
304	Spare circulation pump
308	Condenser pump
310	Reversing valve
312	Bypass valve
313	Electronic expansion valve
317	Immersion heater
318	Circulation pump secondary unit
319	Solenoid valve
340	Temperature guard
341	Start signal
342	External pool off
343	External WCS start
344	Alarm relay
345	Start signal internal brine
346	Start signal cooling

Number/Note	Description
347	Cooling mode
364	Shunt valve hot water
365	Supply line sensor secondary
366	Return line sensor secondary
370	Secondary circuit pump
375	Brine valve
377	Reversing valve volume tank
402	Volume tank sensor
403	Operating pressure switch
404	Brine in sensor cooling mode
405	Radiator out sensor
407	HGW sensor
408	EVU/Smart grid 1
409	Smart grid 2
411	Radiator return sensor
412	Brine out sensor
413	Brine in sensor
414	High pressure switch
416	Discharge pipe sensor
421	Suction gas sensor
422	Dewpoint sensor
431	Liquid line sensor
432	Signal compressor in operation
433	Low pressure transmitter
434	High pressure transmitter
435	Inverter
436	DI 1
437	DI 2
438	DI 3
439	DI 4
440	Spare
441	Communication card
442	Main PCB
443	Sub PCB
444	External alarm

Number/Note	Description
445	DI 5
446	DI 6
447	DI 7
448	DI 8
449	DC-choke
453	Display
455	Indoor hub controller
456	Current Limiter
* Note 8	Alarm
* Note 9	Speed control
* Note 15	Immersion heater or external auxiliary heater
* Note 16	Potential free contact
* Note 17	To outdoor unit
* Note 18	To expansion unit
* Note 19	Communication

Number/Note	Description
* Note 28	230VAC for external loads
* Note 29	Max 5A load
* Note 30	24VAC for external loads
* Note 31	Max 1A load in total
*Note 32	The outdoor unit is equipped with a modbus communication card, which is not shown in this circuit diagram. Terminal F1/F2 is connected to the communication card, instead of to main PCB. For more information about communication card connections, see following page.
*Note 33	15kW immersion heater is optional
*Note 34	Works only together with EM3-card

4.2 Wiring diagram

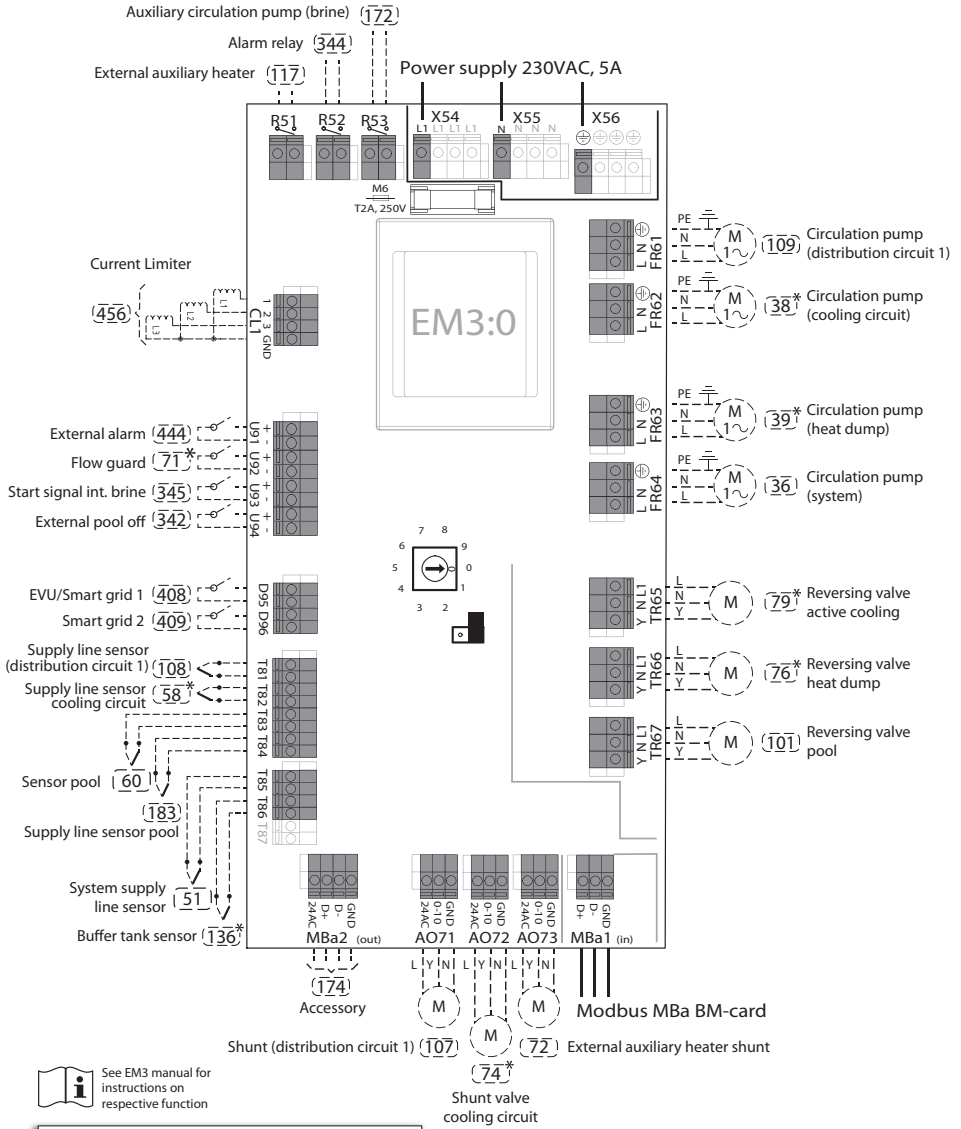

See EM3 manual for instructions on respective function

* N/A for heat pumps with inbuilt cooling







Thermia AB
Box 950
SE 671 29 ARVIKA
Phone +46 570 81300
E-mail: info@thermia.com
Internet: www.thermia.com

Thermia can accept no responsibility for possible errors in catalogues, brochures and other printed material. Thermia reserves the right to alter its products without notice. This also applies to products already on order provided that such alterations can be made without subsequential changes being necessary in specifications already agreed. All trademarks in this material are property of the respective companies. Thermia AB and the Thermia AB logotype are trademarks of Thermia AB. All rights reserved.
